

Lecture Note
on
Electrical Measurement & Instrumentation
(Th. 3)
of
4th semester, Electrical Engineering Branch

Contents Written by
Mrs. Nibedita Ho, Lecturer in Electrical Engineering,
Govt. Polytechnic, Bhadrak, Odisha

Contents

<u>Sl. No</u>	<u>Topic Name</u>	<u>Page No</u>
1	Measuring Instruments	3 - 13
2	Analog ammeters and voltmeters	14 - 28
3	Wattmeter and Measurement of power	29 - 35
4	Energy meters and Measurement of energy	36 - 43
5	Measurement of speed,frequency and power factor	44 - 57
6	Measurement of resistance,inductance &capacitance	58 - 70
7	Sensors And Transducers	71 - 89
8	Oscilloscope	90 - 98

TOPIC- 1

MEASURING INSTRUMENTS

MEASURING INSTRUMENTS

INTRODUCTION

- Measurement is the act, or the result, of a quantitative comparison between a given quantity and a quantity of the same kind chosen as a unit. The result of the measurement is expressed by a pointer deflection over a predefined scale or a number representing the ratio between the unknown quantity and the standard.
- A standard is defined as the physical personification of the unit of measurement or its sub- multiple or multiple values.
- The device or instrument used for comparing the unknown quantity with the unit of measurement or a standard quantity is called a *measuring instrument*.
- The value of the unknown quantity can be measured by direct or indirect methods.
- In direct measurement methods, the unknown quantity is measured directly instead of comparing it with a standard. Examples of direct measurement are current by ammeter, voltage by voltmeter, resistance by ohmmeter, power by wattmeter, etc.
- In indirect measurement methods, the value of the unknown quantity is determined by measuring the functionally related quantity and calculating the desired quantity rather than measuring it directly. Suppose the resistance as (R) of a conductor can be measured by measuring the voltage drop across the conductor and dividing the voltage (V) by the current

(I) through the conductors, by Ohm's law.
$$R = \frac{V}{I}$$

DEFINITIONS OF SOME STATIC CHARACTERISTICS

Accuracy:

Accuracy is the closeness with which the instrument reading approaches the true value of the variable under measurement. Accuracy is determined as the maximum amount by which the result differs from the true value. It is almost impossible to determine experimentally the true value. The true value is not indicated by any measurement system due to the loading effect, lags and mechanical problems (e.g., wear, hysteresis, noise, etc.).

Accuracy of the measured signal depends upon the following factors:

- Intrinsic accuracy of the instrument itself;
- Accuracy of the observer;
- Variation of the signal to be measured; and
- Whether or not the quantity is being truly impressed upon the instrument.

Precision:

Precision is a measure of the reproducibility of the measurements, i.e., precision is a measure of the degree to which successive measurements differ from one another. Precision is indicated from the number of significant figures in which it is expressed. Significant figures actually convey the information regarding the magnitude and the measurement precision of a quantity. More significant figures imply greater precision of the measurement

Resolution:

If the input is slowly increased from some arbitrary value it will be noticed that the output does not change at all until the increment exceeds a certain value called the resolution or discrimination of the instrument. Thus, the resolution or discrimination of any instrument is the smallest change in the input signal (quantity under measurement) which can be detected by the instrument. It may be expressed as an accrual value or as a fraction or percentage of the full scale value. Resolution is sometimes referred as sensitivity. The largest change of input quantity for which there is no output of the instrument is called the dead zone of that instrument.

The sensitivity gives the relation between the input signal to an instrument or a part of the instrument system and the output. Thus, the sensitivity is defined as the ratio of output signal or response of the instrument to a change of input signal or the quantity under measurement.

Speed of Response

The quickness of an instrument to read the measurand variable is called the speed of response. Alternately, speed of response is defined as the time elapsed between the start of the measurement to the reading taken. This time depends upon the mechanical moving system, friction, etc.

MEASUREMENT OF ERRORS

In practice, it is impossible to measure the exact value of the measurand. There is always some difference between the measured value and the absolute or true value of the unknown quantity (measurand), which may be very small or may be large. The difference between the true or exact value and the measured value of the unknown quantity is known as the absolute error of the measurement.

If δA be the absolute error of the measurement, A_m and A be the measured and absolute value of the unknown quantity then δA may be expressed as

$$\delta A = A_m - A$$

Sometimes, δA is denoted by ϵ_0 .

The relative error is the ratio of absolute error to the true value of the unknown quantity to be measured,

$$\text{i.e., relative error, } \epsilon_r = \frac{\delta A}{A} = \frac{\epsilon_0}{A} = \frac{\text{Absolute error}}{\text{True value}}$$

When the absolute error ϵ_0 ($=\delta A$) is negligible, i.e., when the difference between the true value A and the measured value A_m of the unknown quantity is very small or negligible then the relative error may be expressed as

$$\epsilon_r = \frac{\delta A}{A_m} = \frac{\epsilon_0}{A_m}$$

The relative error is generally expressed as a fraction, i.e., 5 parts in 1000 or in percentage value,

$$\text{i.e., percentage error} = \epsilon_r \times 100 = \frac{\epsilon_0}{A_m} \times 100$$

CLASSIFICATION OF INSTRUMENTS

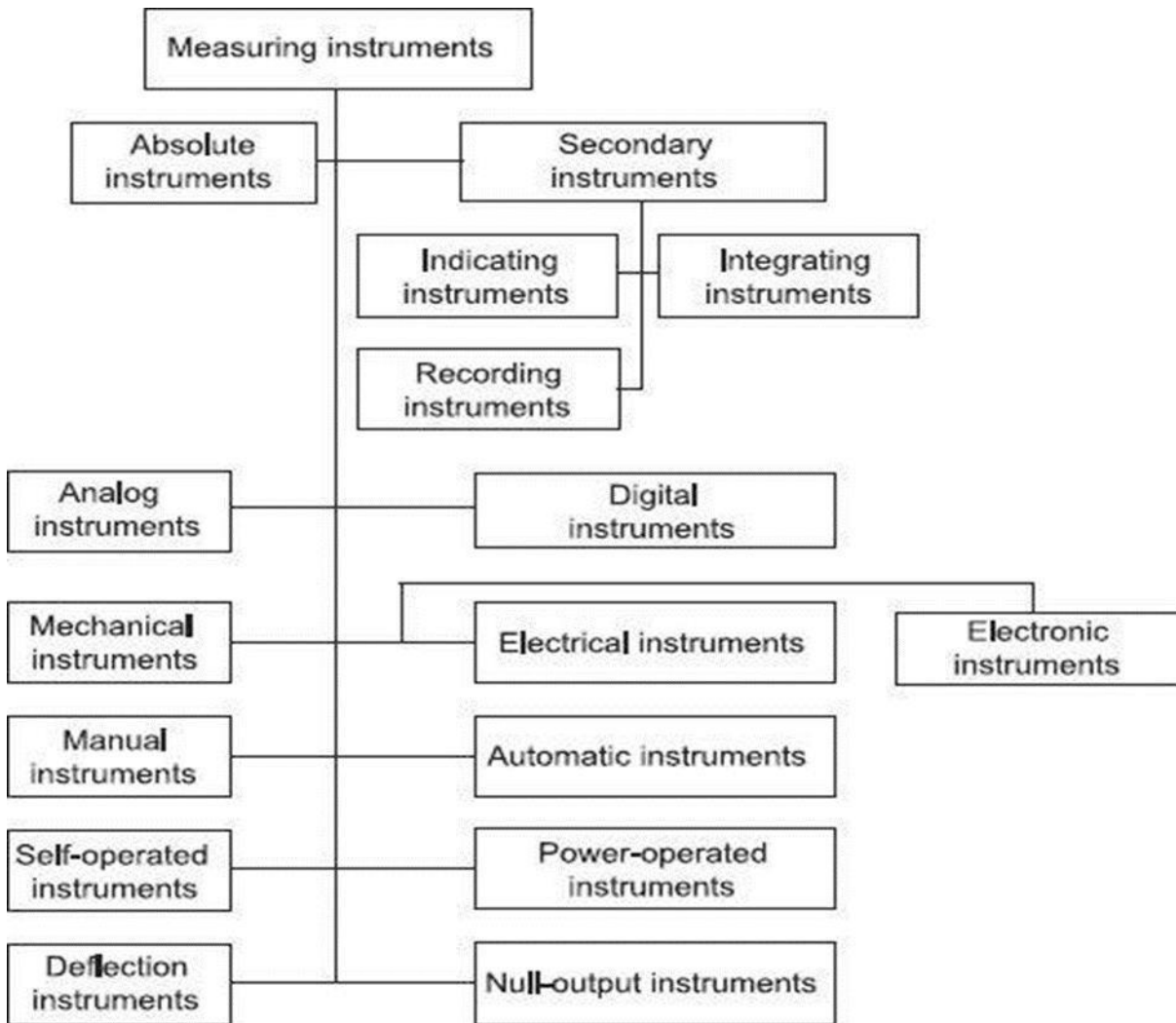

The measuring instruments may be classified as follows:

I. Absolute and Secondary Instruments

Absolute Instruments

The instruments of this type give the value of the measurand in terms of instrument constant and its deflection. Such instruments do not require comparison with any other standard. The example of this type of instrument is tangent galvanometer, which gives the value of the current to be measured in terms of tangent of the angle of deflection produced, the horizontal component of the earth's magnetic field, the radius and the number of turns of the wire used. Rayleigh current balance and absolute electrometer are other examples of absolute instruments. Absolute instruments are mostly used in standard laboratories and in similar institutions as standardizing.

Secondary Instruments

These instruments are so constructed that the deflection of such instruments gives the magnitude of the electrical quantity to be measured directly. These instruments are required to be calibrated by comparison with either an absolute instrument or with another secondary instrument, which has already been calibrated before the use. These instruments are generally used in practice.

Secondary instruments are further classified as

- Indicating instruments
- Integrating instruments
- Recording instruments

Indicating Instruments:

Indicating instruments are those which indicate the magnitude of an electrical quantity at the time when it is being measured. The indications are given by a pointer moving over a calibrated (pregraduated) scale. Ordinary ammeters, voltmeters, wattmeters, frequency meters, power factor meters, etc., fall into this category.

(i) Integrating Instruments:

Integrating instruments are those which measure the total amount of either quantity of electricity (ampere-hours) or electrical energy supplied over a period of time. The summation, given by such an instrument, is the product of time and an electrical quantity under measurement. The ampere-hour meters and energy meters fall in this class.

(ii) Recording Instruments:

Recording instruments are those which keep a continuous record of the variation of the magnitude of an electrical quantity to be observed over a definite period of time. In such instruments, the moving system carries an inked pen which touches lightly a sheet of paper wrapped over a drum moving with uniform slow motion in a direction perpendicular to that of the direction of the pointer. Thus, a curve is traced which shows the variations in the magnitude of the electrical quantity under observation over a definite period of time. Such instruments are generally used in powerhouses where the current, voltage, power, etc., are to be maintained within certain acceptable limit.

II. Analog and Digital Instruments**1. Analog Instruments**

The signals of an analog unit vary in a continuous fashion and can take on infinite number of values in a given range. Fuel gauge, ammeter and voltmeters, wrist watch, speedometer fall in this category.

2. Digital Instruments

Signals varying in discrete steps and taking on a finite number of different values in a given range are digital signals and the corresponding instruments are of digital type. Digital instruments have some advantages over analog meters, in that they have high accuracy and high speed of operation. It eliminates the human operational errors. Digital instruments can store the result for future purposes. A digital multimeter is the example of a digital instrument.

III. Mechanical, Electrical and Electronics Instruments**1. Mechanical Instruments**

Mechanical instruments are very reliable for static and stable conditions. They are unable to respond rapidly to the measurement of dynamic and transient conditions due to the fact that they have moving parts that are rigid, heavy and bulky and consequently have a large mass. Mass presents inertia problems and hence these instruments cannot faithfully follow the rapid changes which are involved in dynamic instruments. Also, most of the mechanical instruments cause noise pollution.

Advantages of Mechanical Instruments

- Relatively cheaper in cost
- More durable due to rugged construction
- Simple in design and easy to use
- No external power supply required for operation
- Reliable and accurate for measurement of stable and time invariant quantity

Disadvantages of Mechanical Instruments

- Poor frequency response to transient and dynamic measurements
- Large force required to overcome mechanical friction
- Incompatible when remote indication and control needed
- Cause noise pollution

2. Electrical Instruments

When the instrument pointer deflection is caused by the action of some electrical methods then it is called an electrical instrument. The time of operation of an electrical instrument is more rapid than that of a mechanical instrument. Unfortunately, an electrical system normally depends upon a mechanical measurement as an indicating device. This mechanical movement has some inertia due to which the frequency response of these instruments is poor.

3. Electronic Instruments

Electronic instruments use semiconductor devices. Most of the scientific and industrial instrumentations require very fast responses. Such requirements cannot be met with by mechanical and electrical instruments. In electronic devices, since the only movement involved is that of electrons, the response time is extremely small owing to very small inertia of the electrons. With the use of electronic devices, a very weak signal can be detected by using pre-amplifiers and amplifiers.

Advantages of Electrical/Electronic Instruments

- Non-contact measurements are possible
- These instruments consume less power
- Compact in size and more reliable in operation
- Greater flexibility
- Good frequency and transient response
- Remote indication and recording possible
- Amplification produced greater than that produced in mechanical instruments

IV. Manual and Automatic Instruments

In case of manual instruments, the service of an operator is required. For example, measurement of temperature by a resistance thermometer incorporating a Wheatstone bridge in its circuit, an operator is required to indicate the temperature being measured. In an automatic type of instrument, no operator is required all the time. For example, measurement of temperature by mercury-in-glass thermometer.

- V. Self-operated and Power-operated Instruments** Self-operated instruments are those in which no outside power is required for operation. The output energy is supplied wholly or almost wholly by the input measurand. Dial-indicating type instruments belong to this category.

The power-operated instruments are those in which some external power such as electricity, compressed air, hydraulic supply is required for operation. In such cases, the input signal supplies only an insignificant portion of the output power.

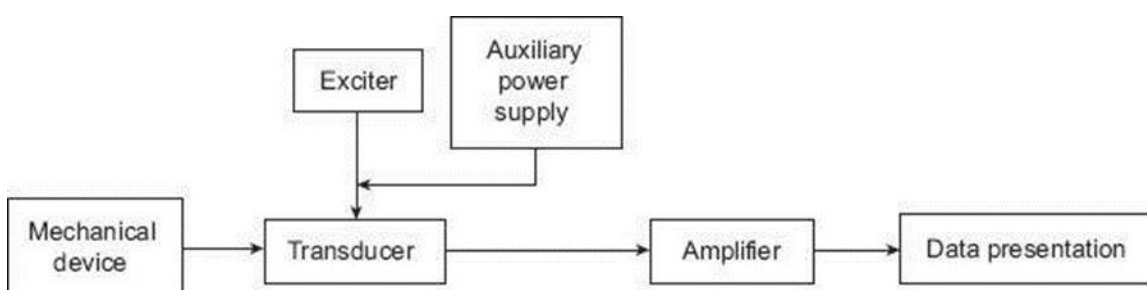

VI. Deflection and Null Output Instruments

In a deflection-type instrument, the deflection of the instrument indicates the measurement of the unknown quantity. The measurand quantity produces some physical effect which deflects or produces a mechanical displacement in the moving system of the instrument. An opposite effect is built in the instrument which opposes the deflection or the mechanical displacement of the moving system. The balance is achieved when opposing effect equals the actuating cause producing the deflection or the mechanical displacement. The deflection or the mechanical displacement at this point gives the value of the unknown input quantity. These types of instruments are suited for measurement under dynamic condition. Permanent Magnet Moving Coil (PMMC), Moving Iron (MI), etc., type instruments are examples of this category.

In null-type instruments, a zero or null indication leads to determination of the magnitude of the measurand quantity. The null condition depends upon some other known conditions. These are more accurate and highly sensitive as compared to deflection-type instruments. A dc potentiometer is a null-type instrument.

OPERATING TORQUES

Three types of torques are needed for satisfactory operation of any indicating instrument. These are

1. Deflecting torque
2. Controlling torque
3. Damping torque

Deflecting Torque/Force

Any instrument's deflection is found by the total effect of the deflecting torque/force, control torque/force and damping torque/force. The deflecting torque's value is dependent upon the electrical signal to be measured; this torque/force helps in rotating the instrument movement from its zero position. The system producing the deflecting torque is called the *deflecting system*.

Controlling Torque/Force

The act of this torque/force is opposite to the deflecting torque/force. When the deflecting and controlling torques are equal in magnitude then the movement will be in definite position or in equilibrium. Spiral springs or gravity is usually given to produce the controlling torque. The system which produces the controlling torque is called the *controlling system*.

The functions of the controlling system are

1. To produce a torque equal and opposite to the deflecting torque at the final steady position of the pointer in order to make the deflection of the pointer definite for a particular magnitude of current
2. To bring the moving system back to its zero position when the force causing the instrument moving system to deflect is removed

The controlling torque in indicating instruments is almost always obtained by a spring, much less commonly, by gravity.

Damping Torque/Force

A damping force generally works in an opposite direction to the movement of the moving system. This opposite movement of the damping force, without any oscillation or very small oscillation brings the moving system to rest at the final deflected position quickly. Air friction, fluid friction and eddy currents provide the damping torque/force to act. It must also be noted that not all damping force affects the steady-state deflection caused by a given deflecting force or torque. With the angular velocity of the moving system, the intensity of the damping force rises; therefore, its effect is greatest when it rotates rapidly and zero when the system rotation is zero. In the description of various types of instruments, detailed mathematical expressions for the damping torques are taken into consideration.

When the deflecting torque is much greater than the controlling torque, the system is called underdamped. If the deflecting torque is equal to the controlling torque, it is called *critically damped*. When deflecting torque is much less than the controlling torque, the system is under overdamped condition.

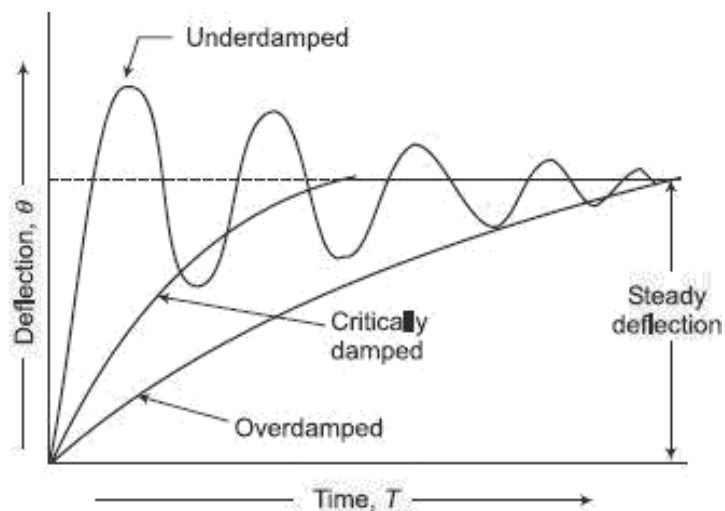

Controlling System

The controlling torque is provided by a spring or sometimes by gravity.

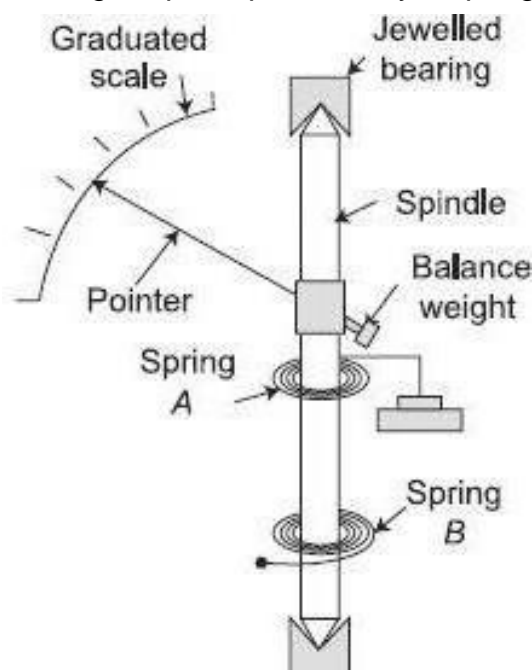

Spring Control

A hair-spring, usually of phosphor-bronze attached to the moving system, is used in indicating instruments for control purpose.

To give a controlling torque which is directly proportional to the angle of deflection of the moving system, the number of turns on the spring should be fairly large, so that the deflection per unit length is small. The stress in the spring must be limited to such a value that there is no permanent set.

Suppose that a spiral spring is made up of a total length L m of strip whose cross-section is rectangular, the radial thickness being t m and the

depth b m. Let E be Young's modulus (N/m^2) for the material of the spring. Then, if θ radians be the deflection of the moving system to which one end of the spring is being attached, the expression for the controlling torque is

$$T_c = \frac{Ebt^3}{12L} \theta$$

Thus, controlling torque $\propto \theta \propto$ instrument deflection.

Gravity Control

In a gravity-controlled instrument, a small weight is attached to the moving system in such a way that it produces a restoring or controlling torque when the system is deflected. The controlling torque, when the deflection is θ , is $\omega l \sin \theta$, where W is the control weight and l its distance from the axis of rotation of the moving system, and it is, therefore, proportional only to the *sine* of the angle of deflection, instead of, as with spring control, being directly proportional to the angle of deflection. Gravity-controlled instruments must obviously be used in a vertical position in order that the control may operate.

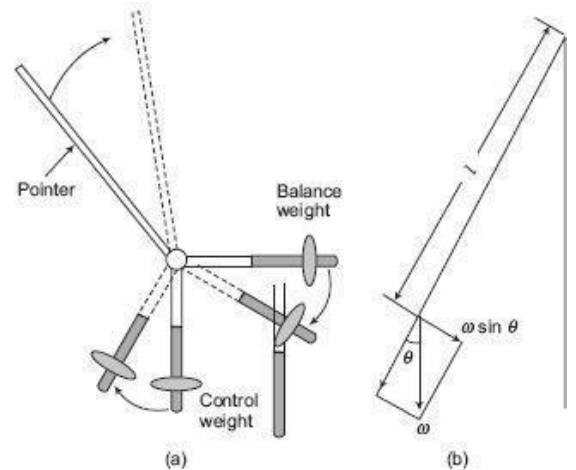

Comparison of Spring and Gravity Control

Gravity control has the following advantages when compared with spring control:

- It is cheaper
- Independent of temperature
- Does not deteriorate with time

Consider an instrument in which the deflecting torque T_D is directly proportional to the current (say) to be measured.

Thus, if I is the current,

$$T_D = kI, \text{ (where } k \text{ is a constant)}$$

If the instrument is spring-controlled, the controlling torque being T_C , when the deflection is θ , $T_C = k_s \theta$ (k_s is spring constant)

$$\text{Also, } T_C = T_D$$

$$\text{or } k_s \theta = kI$$

$$\text{or } k_s \theta = kI$$

$$\therefore \theta = \frac{k}{k_s} \cdot I$$

Thus, the deflection is proportional to the current throughout the scale.

Now if the same instrument is gravity controlled,

$$T = k_g \sin \theta \quad (k \text{ is a constant that depends upon the control weight})$$

$$\text{And } T_C = T_D = kI$$

$$\therefore k_g \sin \theta = kI$$

$$\sin \theta = \frac{k}{k_g} \cdot I$$

$$\theta = \sin^{-1} \left(\frac{k}{k_g} \cdot I \right)$$

Thus, a gravity-controlled instrument would have a scale which is 'cramped' at its lower end instead of being uniformly divided, though the deflecting torque is directly proportional to the quantity to be measured.

Damping System

There are three systems of damping generally used. These are as follows:

- Air-friction damping
- Fluid-friction damping
- Eddy-current damping

Air-Friction Damping

In this method, a light aluminium piston is attached to the moving system and moves in an air chamber closed at one end. The cross-section of this chamber may be either circular or rectangular. The clearance between the piston and the sides of the chamber should be small and uniform. If the piston is moving rapidly into the chamber, the air in the closed space is compressed and the pressure opposes the motion of the piston (and, therefore, of the whole moving system). If the piston is moving out of the chamber rapidly, the pressure in the closed space falls, and the pressure on the open side of the piston is greater than that on the opposite side. Motion is thus again opposed. Sometimes instead of a piston, a vane, mounted on the spindle of the moving system, moves in a closed-sector-shaped box.

Fluid-Friction Damping

In this type of damping, a light vane, attached to the spindle of the moving system, dips into a pot of damping oil and should be completely submerged by the oil. The frictional drag in the disc is always in the direction opposing motion. There is no friction force when the disc is stationary. In the second system, increased damping is obtained by the use of vanes.

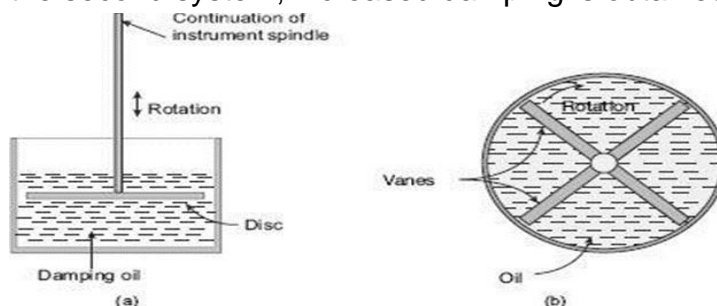

Eddy-Current Damping

When a sheet of conducting material moves in a magnetic field so as to cut through lines of force, eddy currents are set up in it and a force exists between these currents and the magnetic field, which is always in the direction opposing the motion. The force is magnitude of the current is proportional to the velocity of movement of the conductor, and thus, if the magnetic field is constant, the damping force is proportional to the velocity of the moving system and is zero when there is no movement of the system.

Eddy-Current Damping Torque of Metal Former shows a metallic former moving in the field of a permanent magnet.

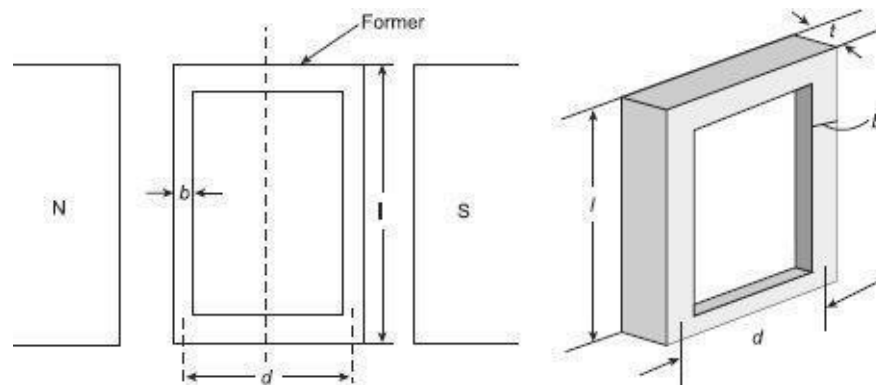

CHAPTER-2

ANALOG AMMETERS AND VOLTMETERS

INTRODUCTION

An analog device is one in which the output or display is a continuous function of time and bears a constant relation to its input. Measuring instruments are classified according to both the quantity measured by the instrument and the principle of operation. Three general principles of operation are available: (i) electromagnetic, which utilizes the magnetic effects of electric currents; (ii) electrostatic, which utilizes the forces between electrically charged conductors; (iii) electro-thermal, which utilizes the heating effect.

Electric measuring instruments and meters are used to indicate directly the value of current, voltage, power or energy. In this chapter, we will consider an electromechanical meter (input is as an electrical signal which results in mechanical force or torque as an output) that can be connected with additional suitable components in order to act as an ammeter and a voltmeter. The most common analog instrument or meter is the permanent magnet moving coil instrument and it is used for measuring a dc current or voltage of an electric circuit. On the other hand, the indications of alternating current ammeters and voltmeters must represent the rms values of the current, or voltage, respectively, applied to the instrument.

CLASSIFICATION OF ANALOG INSTRUMENTS

In a broad sense, analog instruments may be classified into two ways:

- Absolute instruments
- Secondary instruments

Absolute instruments give the value of the electrical quantity to be measured in terms of the constants of the instruments and to its deflection, no comparison with another instrument being required. For example, the tangent galvanometer gives the value of the current to be measured in terms of the tangent of the angle of deflection produced by the current, the radius and the number of turns of galvanometer coil, and the horizontal component of the earth's magnetic field. No calibration of the instrument is thus necessary.

Secondary instruments are so constructed that the value of current, voltage or other quantity to be measured can be determined from the deflection of the instruments, only if the latter has been calibrated by comparison with either an absolute instrument or one which has already been calibrated. The deflection obtained is meaningless until such a calibration has been made.

This class of instruments is in most general use, absolute instrument being seldom used except in standard laboratories and similar institutions.

The secondary instruments may be classified as

- Indicating instruments
- Recording instruments
- Integrating instruments

Indicating instruments are instruments which indicate the magnitude of a quantity being measured. They generally make use of a dial and a pointer for this purpose.

Recording instruments give a continuous record of the quantity being measured over a specified period. The variation of the quantity being measured are recorded by a pen (attached to the moving system of the instrument; the moving system is operated by the quantity being measured) on a sheet of paper that moves perpendicular to the movement of the pen.

Integrating instruments record totalized events over a specified period of time. The summation, which they give, is the product of time and an electrical quantity. Ampere hour and watt hour (energy) meters are examples of this category.

PRINCIPLE OF OPERATION

Analog instruments may be classified according to the principle of operation they utilise. The effects they utilise are

- Magnetic effect
- Heating effect
- Electrostatic effect
- Electromagnetic effect
- Hall effect

The majority of analog instruments including moving coil, moving iron and electrodynamic utilise the magnetic effect. The effect of the heat produced by a current in a conductor is used in thermocouple and hotwire instruments. Electrostatic effect is used in electrostatic voltmeters. The electromagnetic induction effect is used in induction wattmeters and induction energy meters.

PERMANENT MAGNET MOVING COIL :

Principle of Operation

The principle on which a Permanent Magnet Moving Coil (PMMC) instrument operates is that a torque is exerted on a current-carrying coil placed in the field of a permanent magnet. The coil C has a number of turns of thin insulated wires wound on a rectangular aluminium former F . The frame is carried on a spindle S mounted in jewel bearings J_1, J_2 . A pointer PR is attached to the spindle so that it moves over a calibrated scale. The whole of the moving system is made as light in weight as possible to keep the friction at the bearing to a minimum.

The coil is free to rotate in air gaps formed between the shaped soft-iron pole piece (pp) of a permanent magnet PM and a fixed soft-iron cylindrical core IC . The core serves two purposes; (a) it intensifies the magnetic field by reducing the length of the air gap, and (b) it makes the field radial and uniform in the air gap.

Thus, the coil always moves at right angles to the magnetic field. Modern permanent magnets are made of steel alloys which are difficult to machine. Soft-iron pole pieces (pp) are attached to the permanent magnet PM for easy machining in order to adjust the length of the air gap.

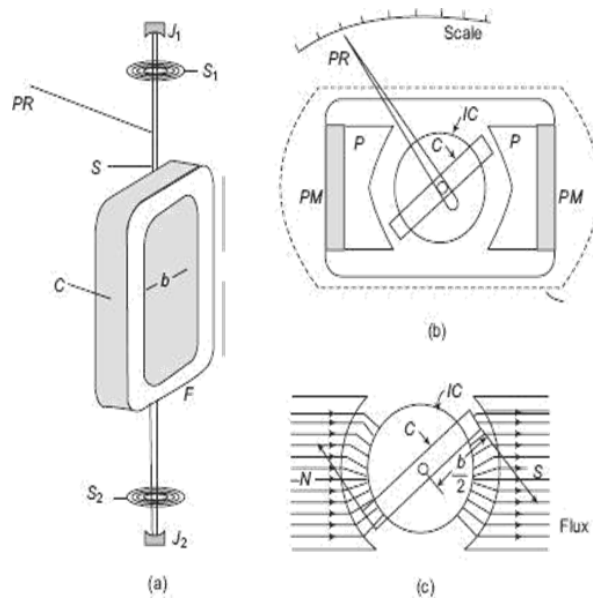

A soft-iron yoke (Y) is used to complete the flux path and to provide shielding from stray external fields.

Deflecting Torque Equation of PMMC Instrument

Let, B = flux density in the air gap (wb/m^2)

i = current in the coil (A)

l = effective axial length of the coil

(m) b = breadth of the coil (m)

n = number of turns of the coil.

Force on one side of the coil is $F = Biln$ (N)

Torque on each side of the coil,

$$\begin{aligned} T &= \text{force} \times \text{distance from axis of rotation} \\ &= F \times b/2 \\ &= Biln \times b/2 \end{aligned}$$

Total deflecting torque exerted on the coil,

$$\begin{aligned} T_d &= 2 \times T = 2iln \times b/2 \\ &= Bilnb \text{ (N-m)} \end{aligned}$$

For a permanent magnet, B is constant. Also, for a given coil l , b and n are constants and thus the product ($Bilnb$) is also a constant, say k_1 .

Therefore, $T_d = k_1 \times i$

Control Torque The control on the movement of the pointer over the scale is provided by two spirally wound, phosphor-bronze springs S_1 and S_2 , one at each end of the spindle S . Sometimes these springs also conduct the current into and out of the coil.

The control torque of the springs is proportional to the angle θ turned through by the coil.

$$T_c = k_s \times \theta$$

Where, T_c is the control torque and k_s is the spring constant.

At final steady state position, Control torque = Deflecting torque

$$\therefore \quad T_c = T_d$$

$$k_s \theta = k_1 i$$

$$\text{or} \quad \theta = \frac{k_1}{k_s} i = ki$$

$$\text{where } k = \frac{k_1}{k_s} = \text{constant}$$

So, angular deflection of the pointer is directly proportional to the current. Thus the scale of the instrument is linear or uniformly divided.

Damping Torque When the aluminium former (F) moves with the coil in the field of the permanent magnet, a voltage is induced, causing eddy current to flow in it. These current exerts a force on the former. By Lenz's law, this force opposes the motion producing it. Thus, a damping torque is obtained. Such a damping is called eddy-current damping.

Advantages of PMMC Instruments

- Sensitive to small current
- Very accurate and reliable
- Uniform scale up to 270° or more
- Very effective built in damping
- Low power consumption, varies from $25 \mu\text{W}$ to $200 \mu\text{W}$
- Free from hysteresis and not effected by external fields because its permanent magnet shields the coil from external magnetic fields
- Easily adopted as a multirange instrument

Disadvantages of PMMC Instruments

- This type of instrument can be operated in direct current only. In alternating current, the instrument does not operate because in the positive half, the pointer experiences a force in one direction and in the negative half the pointer experiences the force in the opposite direction. Due to the inertia of the pointer, it retains it's zero position.
- The moving system is very delicate and can easily be damaged by rough handling.
- The coil being very fine, cannot withstand prolonged overloading.
- It is costlier.
- The ageing of the instrument (permanent magnet and control spring) may introduce some errors.

EXTENSION OF RANGE OF PMMC INSTRUMENTS

Ammeter Shunts

The moving-coil instrument has a coil wound with very fine wire. It can carry only few mA safely to give full-scale deflection. For measuring higher current, a low resistance is connected in parallel to the instrument to bypass the major part of the current. The low resistance connected in parallel with the coil is called a *shunt*.

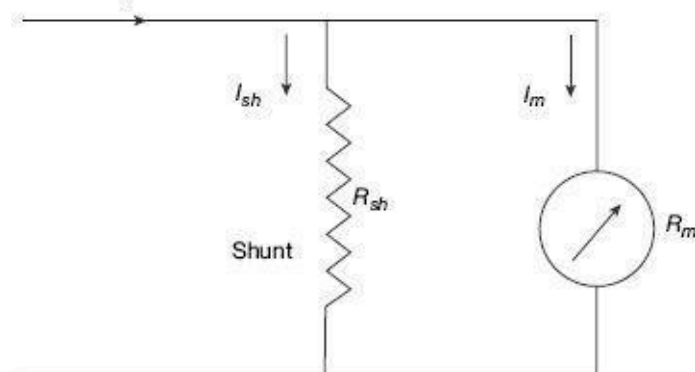

The resistance of the shunt can be calculated using conventional circuit analysis.

R_{sh} = shunt resistance

(Ω) R_m = coil resistance

(Ω)

I_m = I_{fs} = full-scale deflection current

(A) I_{sh} = shunt current (A)

I = current to be measured (A)

The voltage drop across the shunt and the meter must be same as they are connected in parallel.

$$\begin{aligned} R_{sh} &= \frac{I_m}{I_{sh}} R_m & \therefore & I_{sh} R_{sh} = I_m R_m \\ \therefore R_{sh} &= \frac{I_m}{I - I_m} R_m & \text{Again} & I = I_{sh} + I_m \\ & & \therefore & I_{sh} = I - I_m \end{aligned}$$

The ratio of the total current to the current in the meter is called *multiplying power of shunt*.
Multiplying power,

$$\begin{aligned} m &= \frac{I}{I_m} = 1 + \frac{R_m}{R_{sh}} \\ \therefore R_{sh} &= \frac{R_m}{m - 1} \end{aligned}$$

Voltmeter Multipliers

For measuring higher voltages, a high resistance is connected in series with the instrument to limit the current in the coil to a safe value. This value of current should never exceed the current required to produce the full scale deflection. The high resistance connected in series with the instrument is called a *multiplier*.

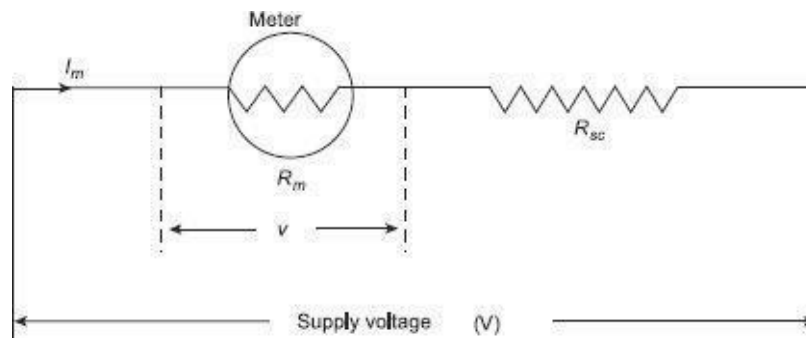

The value of multiplier required to extend the voltage range, is calculated as under:

R_{sc} = multiplier resistance (Ω)

R_m = meter resistance (Ω)

$I_m = I_{fs}$ = full scale deflection current (A)

v = voltage across the meter for producing current I_m

(A) V = voltage to be measured (A)

$$V = I_m R_m$$

$$V = I_m (R_m + R_{sc})$$

$$\therefore R_{sc} = \frac{V - I_m R_m}{I_m} = \frac{V}{I_m} - R_m$$

$$m = \frac{V}{v} = \frac{I_m (R_m + R_{sc})}{I_m R_m} = 1 + \frac{R_{sc}}{R_m}$$

$$\therefore R_{sc} = (m - 1)R_m$$

Sensitivity The moving-coil instrument is a very sensitive instrument. It is, therefore, widely used for measuring current and voltage. The coil of the instrument may require a small amount of current (in the range of μA) for full-scale deflection. The sensitivity is sometimes expressed in *ohm/volt*. The sensitivity of a voltmeter is given by

$$S = \frac{\text{Total voltmeter resistance in ohm}}{\text{Full scale reading in volts}} \Omega/v = \frac{R_m}{v} = \frac{1}{I_{fs}} \Omega/v$$

Where, I_{fs} is the full-scale deflecting current. Thus, the sensitivity depends upon on the current to give full-scale deflection.

MOVING-IRON INSTRUMENTS

Moving-Iron or MI instruments can be classified as

- Attraction-type moving-iron instruments
- Repulsion-type moving-iron instruments

The current to be measured, in general, is passed through a coil of wire in the moving-iron instruments. In case of voltage measurement, the current which is proportional to the voltage is measured. The number of turns of the coil depends upon the current to be passed through it. For operation of the instrument, a certain number of ampere turns is required. These ampere turns can be produced by the product of few turns and large current or reverse.

Attraction-type Moving-Iron Instruments

The attraction type of MI instrument depends on the attraction of an iron vane into a coil carrying current to be measured. A soft iron vane *IV* is attached to the moving system. When the current to be measured is passed through the coil *C*, a magnetic field is produced. This field attracts the eccentrically mounted vane on the spindle towards it. The spindle is supported at the two ends on a pair of jewel bearings. Thus, the pointer *PR*, which is attached to the spindle *S* of the moving system is deflected. The pointer moves over a calibrated scale.

The control torque is provided by two hair springs S_1 and S_2 in the same way as for a PMMC instrument; but in such instruments springs are not used to carry any current. Gravity control can also be used for vertically mounted panel type MI meters. The damping torque is provided by the movement of a thin vane *V* in a closed sector-shaped box *B*, or simply by a vane attached to the moving system. Eddy current damping can not be used in MI instruments owing to the fact that any permanent magnet that will be required to produce Eddy current damping can distort the otherwise weak operating magnetic field produced by the coil.

If the current in the fixed coil is reversed, the field produced by it also reverses. So the polarity induced on the vane reverses. Thus whatever be the direction of the current in the coil the vane is always be magnetized in such a way that it is attracted into the coil. Hence such instrument can be used for both direct current as well as alternating current.

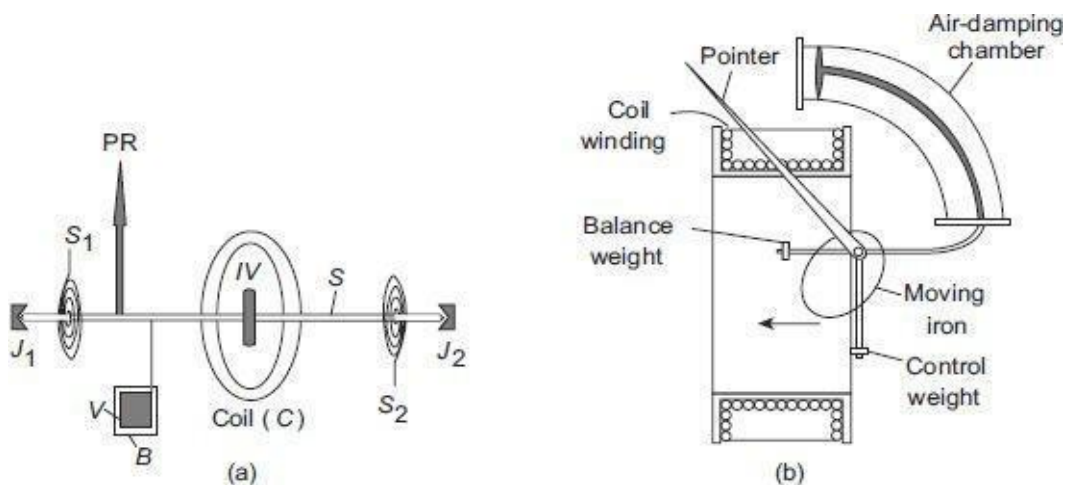

Repulsion-type Moving-Iron Instruments

In the repulsion type, there are two vanes inside the coil. One is fixed and the other is movable. These are similarly magnetised when the current flows through the coil and there is a force of repulsion between the two vanes resulting in the movement of the moving vane.

Two different designs for moving iron instruments commonly used are as follows:

Radial Vane Type In this type, the vanes are radial strips of iron. The fixed vane is attached to the coil and the movable one to the spindle of the instrument. The instrument pointer is attached to the moving vane spindle.

As current flows through the coil, the generated magnetic field induces identical polarities on both the fixed and moving vane. Thus, even when the current through the coil is alternating (for AC measurement), there is always a repulsion force acting between the like poles of fixed and moving vane. Hence deflection of the pointer is always in the same direction irrespective of the polarity of current in the coil. The amount of deflection depends on the repulsion force between the vanes which

in turn depends on the amount of current passing through the coil. The scale can thus be calibrated to read the current or voltage directly.

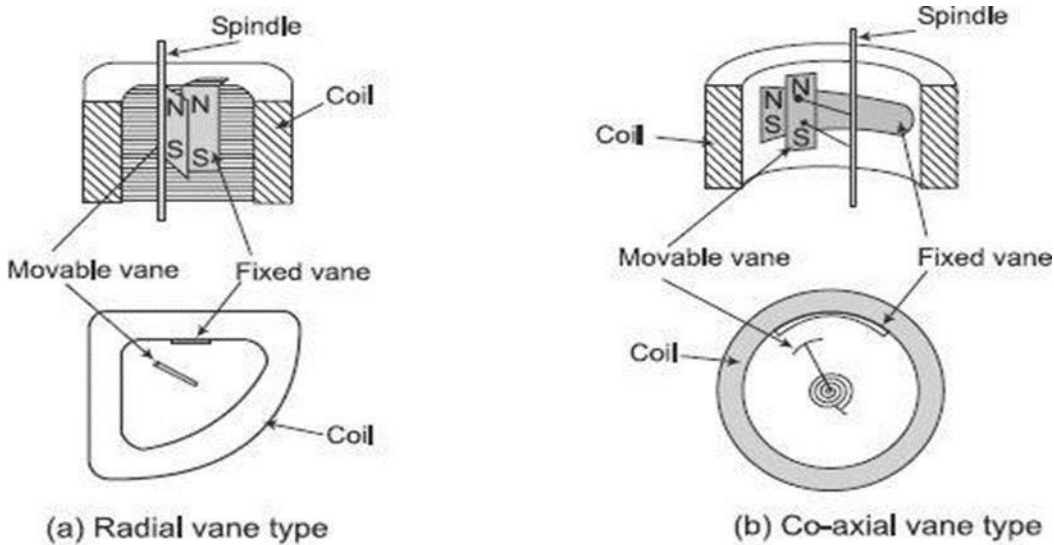

Co-axial Vane Type | In these type of instruments, the fixed and moving vanes are sections of coaxial cylinders. Current in the coil magnetizes both the vanes with similar polarity. Thus the movable vane rotates along the spindle axis due to this repulsive force. Coaxial vane type instruments are moderately sensitive as compared to radial vane type instruments that are more sensitive.

Moving iron instruments have their deflection is proportional to the square of the current flowing through the coil. These instruments are thus said to follow a square law response and have non-uniform scale marking. Deflection being proportional to square of the current, whatever be the polarity of current in the coil, deflection of a moving iron instrument is in the same direction. Hence, moving iron instruments can be used for both DC and AC measurements.

Advantages of MI Instruments

- Robust construction and relatively cheap
- Suitable for measuring both dc and ac
- Can withstand overload momentarily

Disadvantages of MI Instruments

- As the deflection is proportional to I^2 , hence the scale of the instrument is not uniform. It is cramped in the lower end and expanded in the upper portion.
- It is affected by stray magnetic fields.
- There is hysteresis error in the instrument. The hysteresis error may be minimized by using the vanes of nickel-iron alloy.
- When used for measuring ac the reading may be affected by variation of frequency due to the change in reactance of the coil, which has some inductance. With the increase in frequency iron losses and coil impedance increases.
- Since large amount of power is consumed to supply I^2R loss in the coil and magnetic losses in the vanes, it is not a very sensitive instrument.

ELECTRODYNAMOMETER-TYPE INSTRUMENTS

The electro-dynamometer is a transfer-type instrument. A transfer-type instrument is one that may be calibrated with a dc source and then used without modification to measure ac. This requires the transfer type instruments to have same accuracy for both dc and ac.

The electrodynamic or dynamometer-type instrument is a moving-coil instrument but the magnetic field, in which the coil moves, is provided by two fixed coils rather than by permanent magnets. It consists of two fixed coils, which are symmetrically situated. It would have a torque in one direction during one half of the cycle and an equal effect in opposite direction during the other half of the cycle. If, however, we were to reverse the direction of the flux each time the current through the movable coil reverses, a unidirectional torque would be produced for both positive half and negative half of the cycle. In electrodynamic instruments, the field can be made to reverse simultaneously with the current in the movable coil if the fixed coil is connected in series with the movable coil.

Controlling Torque The controlling torque is provided by two control springs. These springs act as leads to the moving coil.

Operation with ac Let, i_1 and i_2 be the instantaneous values of current carried by the coils. Therefore, the instantaneous deflecting torque is:

$$T_i = i_1 i_2 \frac{dM}{d\theta}$$

If the two coils are connected in series for measurement of current, the two instantaneous currents i_1 and i_2 are equal.

Say, $i_1 = i_2 = i$

Thus, instantaneous torque on the pointer is $T_i = i^2 \frac{dM}{d\theta}$

Thus, for ac use, the instantaneous torque is proportional to the square of the instantaneous current. As the quantity i^2 is always positive, the current varies and the instantaneous torque also varies. But the moving system due to its inertia cannot follow such rapid variations in the instantaneous torque and responds only to the average torque.

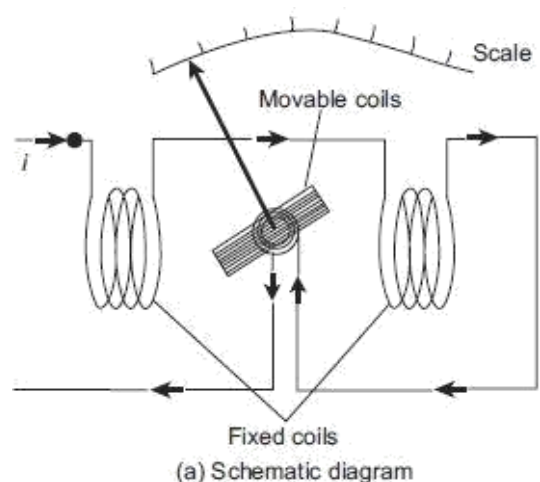

Electrodynamical Ammeter In an electrodynamic ammeter, the fixed and moving coils are connected in series. A shunt is connected across the moving coil for limiting the current. The reactance–resistance ratio of the shunt and the moving coil is kept nearly same for independence of the meter reading with the supply frequency. Since the coil currents are the same, the deflecting torque is proportional to the mean square value of the current. Thus, the scale is calibrated to read the rms value.

Electrodynamical Voltmeter The electrodynamic instrument can be used as a voltmeter by connecting a large noninductive resistance (R) of low temperature coefficient in series with the instrument coil.

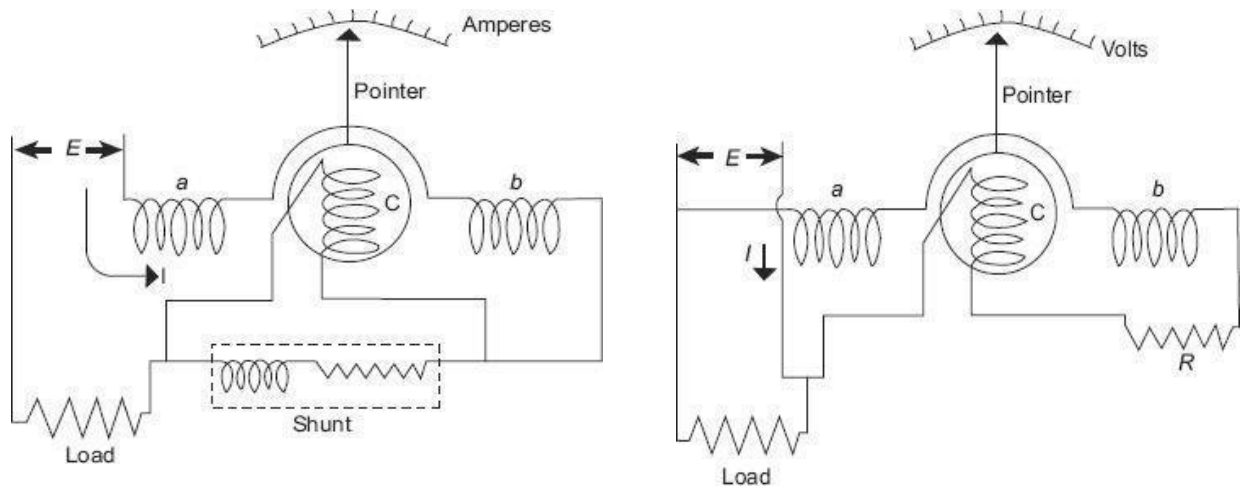

Electrodynamic Wattmeter The electrodynamic wattmeter consists of two fixed coils 'a' and 'b' placed symmetrical to each other and producing a uniform magnetic field. They are connected in series with the load and are called the Current Coils (CC). The two fixed coils can be connected in series or parallel to give two different current ratings. The current coils carry the full-load current or a fraction of full load current. Thus the current in the current coils is proportional to the load current. The moving coil 'c', in series with a high non inductive resistance R_v is connected across the supply. Thus the current flowing in the moving coil is proportional to, and practically in phase with the supply voltage. The moving coil is also called the voltage coil or Pressure Coil (PC). The voltage coil is carried on a pivoted spindle which carries the pointer, the pointer moved over a calibrated scale.

Two hair springs are used for providing the controlling torque and for leading current into and out of the moving coil. Damping is provided by air friction.

Torque Equation

Let, i_f = current in the fixed

coil i_m = current in the

moving coil i = load current

v = load voltage

T_{in} = instantaneous value of the deflecting torque

p = instantaneous power = $T_{in} \times i_f i_m$

$$T_{in} \propto i_f i_m$$

But since $i_f \propto i$ and $i_m \propto v$

$$T_{in} \propto vi \propto p$$

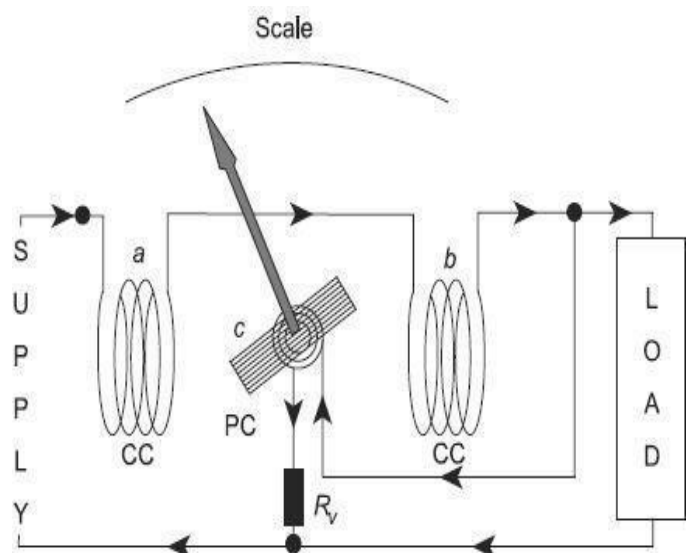

Thus, the instantaneous value of the deflecting torque is proportional to the instantaneous power. Owing to the inertia of the moving system, the pointer reads the average power. In dc circuits, the power is given by the product of voltage and current, and hence the torque is directly proportional to the power. Thus, the instrument indicates the power.

Advantages of Electrodynamic-type Instruments

- They can be used on ac as well as dc measurements.
- These instruments are free from eddy current and hysteresis error.
- Electrodynamic-type instruments are very useful for accurate measurement of rms values of voltages irrespective of waveforms.
- Because of precision grade accuracy and same calibration for ac and dc measurements these instruments are useful as transfer type and calibration instruments.

Disadvantages of Electrodynamic-type Instruments

- As the instrument has square law response, the scale is non-uniform.
- These instruments have small torque/weight ratio, so the frictional error is considerable.
- More costly than PMMC and MI type of instruments.
- Adequate screening of the movements against stray magnetic fields is essential.
- Power consumption is comparably high because of their construction.

RECTIFIER-TYPE INSTRUMENTS

The basic arrangement of a rectifier type of instrument using a full-wave rectifier circuit. If this instrument is used for measuring ac quantity then first the ac signal is converted to dc with the help of the rectifier. Then this dc signal is measured by the PMMC meter. The multiplier resistance R_s , is used to limit the value of the current in order that it does not exceed the current rating of the PMMC meter.

These types of instruments are used for light current work where the voltage is low and resistances high.

Sensitivity of Rectifier-Type Instrument

The dc sensitivity of a rectifier-type instrument is

$$S_{dc} = \frac{1}{I_{fs}} \Omega/V$$

where I_{fs} is the current required to produce full-scale deflection.

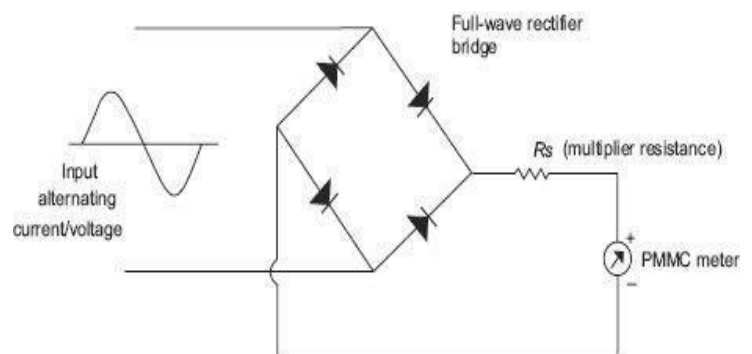

Sensitivity of a Half-wave Rectifier Circuit

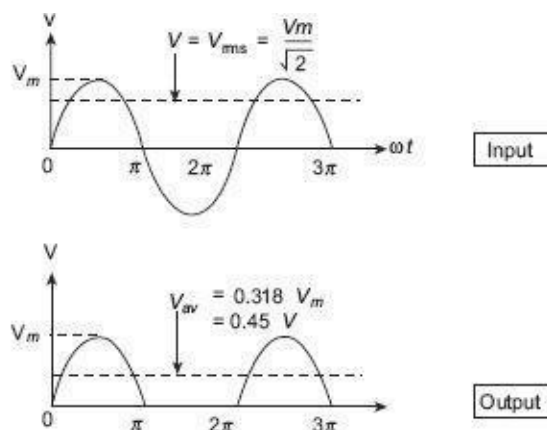
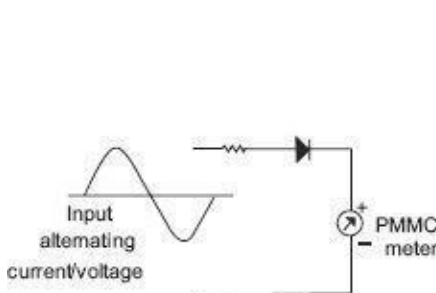

The average value of voltage/current for half-wave rectifier,

$$V_{av} = \frac{1}{2\pi} \int_0^{\pi} V_m \sin \omega t \, d\omega t = \frac{V_m}{\pi} = 0.318V_m = 0.45 \text{ V}$$

Hence, the sensitivity of a half-wave rectifier instrument with ac is 0.45 times its sensitivity with dc and the deflection is 0.45 times that produces with dc of equal magnitude V.

$$S_{ac} = 0.45S_{dc}$$

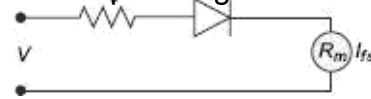

Sensitivity of a Full-wave Rectifier Circuits

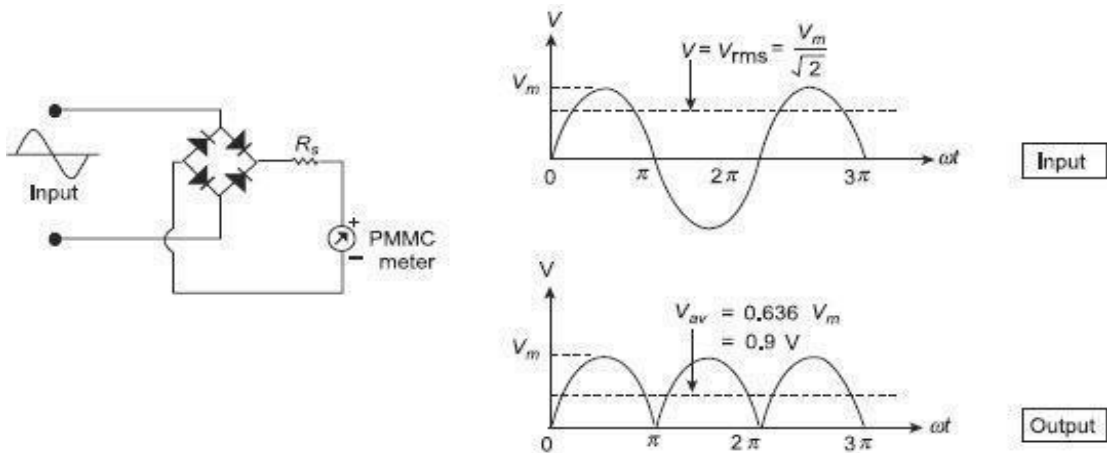

Figure 2.27 Full-wave rectifier

It shows a full-wave rectifier circuit along with the input and output waveform. Average value of voltage/current for full-wave rectifier,

$$V_{av} = \frac{1}{\pi} \int_0^{\pi} V_m \sin \omega t \, d\omega t = \frac{2V_m}{\pi} = 0.636V_m = 0.9 \text{ V}$$

So the deflection is 0.9 times in a full-wave rectifier instrument with an ac than that produced with dc of equal magnitude V.

Sensitivity of a full-wave rectifier instrument with an ac is 0.9 times its sensitivity with dc.

$$S_{ac} = 0.9S_{dc}$$

Extension of Range of Rectifier Instrument as Voltmeter

Suppose it is intended to extend the range of a rectifier instrument which uses a PMMC instrument having a dc sensitivity of S_{dc} .

Let, v = voltage drop across the PMMC

instrument V = applied voltage

Therefore, for dc operation, the values of series resistance (multiplier) needed can be calculated as $V = R_S \cdot I_{fs} + R_d \cdot I_{fs} + R_m \cdot I_{fs}$

$$R_s = \left(\frac{V}{I_{fs}} \right) - R_m - R_d$$

$$= S_{dc} V - R_m - R_d \text{ (for half-wave rectification)}$$

$$= S_{dc} V - R_m - 2R_d \text{ (for full-wave rectification)}$$

Where, R_m = meter resistance

R_d = diode forward

resistance For ac voltmeter,

$$R_s = S_{ac} V - R_m - R_d = 0.45 S_{dc} V - R_m - R_d \text{ (for half-wave)}$$

$$= S_{ac} V - R_m - 2R_d = 0.9 S_{dc} V - R_m - R_d \text{ (for full-wave)}$$

Limitations

- Rectifier instruments are only accurate on the waveforms on which they are calibrated. Since calibration assumes pure sine waves, the presence of harmonics gives erroneous readings.
- The rectifier is temperature sensitive, and therefore, the instrument readings are affected by large variations of temperature.

Applications

- The rectifier instrument is very suitable for measuring alternating voltages in the range of 50– 250 V.
- The rectifier instrument may be used as a micrometer or low milli-ammeter (up to 10– 15 mA). It is not suitable for measuring large currents because for larger currents the rectifier becomes too bulky and providing shunts is impracticable due to rectifier characteristics.

Rectifier instruments find their principal application in measurement in high-impedance circuits at low and audio frequencies. They are commonly used in communications circuits because of their high sensitivity and low power consumption.

COMPARISON BETWEEN DIFFERENT TYPES OF INSTRUMENTS

Sl. No.	Type of Instruments	Suitability for type of measurement	Type of control	Type of damping	Specialty
1.	Moving Coil (i) PMMC	dc measurement (current and voltage only)	Spring	Eddy current	It is most accurate type for dc measurements and most widely used for measurement of dc voltage, current and resistance.
	(ii) Dynamometer	dc or ac measurement (current, voltage and power)	Spring	Air friction	Mainly used as wattmeter. Also used as standard meter for calibration and as transfer instrument.
2.	Moving Iron	dc or ac measurement (current, voltage)	Spring or gravity control	Air friction	It is cheaper to manufacture and mostly used as an indicating instrument. It is very accurate for ac and dc, if properly designed.
3.	Electrostatic	dc or ac (voltage only)	Gravity or spring	Air friction	These instruments have very low power consumption and can be made to cover a large range of voltage. Usually, range is above 500 volts.
4.	Induction	ac measurement (current, voltage, Power and energy) only.	Spring	Eddy current	Ammeters and voltmeters of this type are expensive and not of high degree of accuracy. These instruments are mainly used for measurement of power and energy in ac circuits.
5.	Thermal (i) Hot wire	dc or ac measurement (current, voltage and power)	Spring	Eddy current	These instrument have same calibration for both ac and dc. These are free from errors due to frequency, wave form and external field when used on ac, therefore, these are particularly used for ac measurement.
	(ii) Thermo-couple	dc or ac measurement (current and voltage)			These are free from errors due to frequency, wave form and external field when used on ac and are used for measurement of current and voltage at power frequencies upto 100 MHz.
6.	Rectifier	dc or ac measurement (current and voltage)	Spring	Eddy current	These instruments are nothing but permanent magnet moving coil instruments used in conjunction with rectifying device for AC measurements (current and voltage) from about 20 Hz to 20 kHz.

TOPIC-3

WATTMETER AND MEASUREMENT OF POWER

POWER MEASUREMENT

In alternating current circuits, the instantaneous power varies continuously as the voltage and current varies while going through a cycle. In such a case, the power at any instant is given by

$$p(t) = v(t) \times i(t)$$

where, $p(t)$, $v(t)$, and $i(t)$ are values of instantaneous power, voltage, and current respectively.

Thus, if both voltage and current can be assumed to be sinusoidal, with the current lagging the voltage by phase-angle ϕ , then

$$v(t) = V_m \sin \omega t$$

and
$$i(t) = I_m \sin (\omega t - \phi)$$

where, V_m and I_m are peak values of voltage and current respectively, and ω is the angular frequency.

The instantaneous power p is therefore given by

$$p(t) = V_m I_m \sin \omega t \sin (\omega t - \phi)$$

or,
$$p(t) = \frac{V_m I_m}{2} [\cos \phi - \cos(2\omega t - \phi)]$$

Average value of power over a complete cycle in such a case will be

$$\begin{aligned} P &= \frac{1}{2T} \int_0^{2T} p(t) dt = \frac{1}{2T} \int_0^{2T} \frac{V_m I_m}{2} [\cos \phi - \cos(2\omega t - \phi)] dt \\ &= \frac{V_m I_m}{2T} \int_0^{2T} \left[\cos \phi - \cos \left(\frac{4\pi}{T} t - \phi \right) \right] dt \\ &= \frac{V_m I_m}{2T} \left[\cos \phi t \Big|_0^T - \frac{T}{4\pi} \sin \left(\frac{4\pi}{T} t - \phi \right) \Big|_0^T \right] \\ &= \frac{V_m I_m}{4T} [\cos \phi T - 0] \\ &= \frac{V_m I_m}{2} \cos \phi \\ &= \frac{V_m}{\sqrt{2}} \frac{I_m}{\sqrt{2}} \cos \phi \end{aligned}$$

where, V and I are rms values of voltage and current respectively and $\cos \phi$ is power factor of the load.

Involvement of the power-factor term $\cos \phi$ in the expression for power in ac circuit indicates that ac power cannot be measured simply by connecting a pair of ammeter and voltmeter. A wattmeter, with in-built facility for taking in to account the power factor, can only be used for measurement of power in ac circuits.

ELECTRODYNAMOMETER-TYPE WATTMETER

Construction of Electrodynamicometer-type Wattmeter

1. Fixed Coil System

Such an instrument has two coils connected in different ways to the same circuit of which power is to be measured. The *fixed coils* or the *field coils* are connected in series with the load so as to carry the same current as the load. The fixed coils are hence, termed as the *Current Coils (CC)* of the wattmeter. The main magnetic field is produced by these fixed coils. This coil is divided in two sections so as to provide more uniform magnetic field near the centre and to allow placement of the instrument moving shaft.

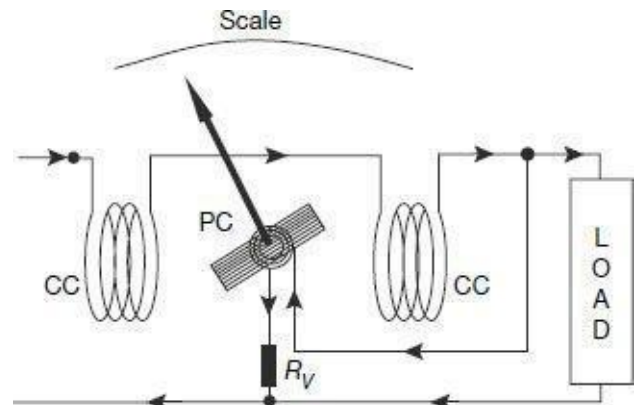

Fixed coils are usually wound with thick wires for carrying the main load current through them. Windings of the fixed coil is normally made of stranded conductors running together but, insulated from each other. All the strands are brought out to an external commutating terminator so that a number of current ranges of the instrument may be obtained by grouping them all in series, all in parallel, or in a series-parallel combination. Such stranding of the fixed coils also reduces Eddy-current loss in the conductors. Still higher current or voltage ranges, however, can be accommodated only through the use of instrument transformers.

Fixed coils are mounted rigidly with the coil supporting structures to prevent any small movement whatsoever and resulting field distortions. Mounting supports are made of ceramic, and not metal, so as not to disturb the magnetic field distribution.

2. Moving Coil System

The **moving coil** that is connected across the load carries a current proportional to the voltage. Since the moving coil carries a current proportional to the voltage, it is called the *voltage coil* or the *pressure coil* or simply *PC* of the wattmeter. The moving coil is entirely embraced by the pair of fixed coils. A high value **non-inductive resistance** is connected in series with the voltage coil to restrict the current through it to a small value, and also to ensure that voltage coil current remains as far as possible in phase with the load voltage.

The moving coil, made of fine wires, is wound either as a self-sustaining air-cored coil, or else wound on a nonmetallic former. A metallic former, otherwise would induce Eddy-currents in them under influence of the alternating field.

2. Movement and Restoring System

The moving, or voltage coil along with the pointer is mounted on an aluminum spindle in case jewel bearings are used to support the spindle. For higher sensitivity requirements, the moving coil may be suspended from a torsion head by a metallic suspension which serves as a lead to the coil. In other constructions, the coil may be suspended by a silk fibre together with a spiral spring which gives the required torsion. The phosphor-bronze springs are also used to lead current into and out of the moving coil. In any case, the torsion head with suspension, or the spring, also serves the purpose of providing the restoring torque to bring the pointer back to its initial position once measurement is over.

The moving, or voltage coil current must be limited to much low values keeping in mind the design requirements of the movement system. Current is lead to and out of the moving coil through two spiral springs. Current value in the moving coil is thus to be limited to values that can be safely carried by the springs without appreciable heating being caused.

3. Damping System

Damping in such instruments may be provided by small aluminum vanes attached at the bottom of the spindle. These vanes are made to move inside enclosed air chambers, thereby creating the damping torque. In other cases, the moving coil itself can be stitched on a thin sheet of mica, which acts as the damping vane while movements. Eddy-current damping, however, cannot be used with these instruments. This is due to the fact that any metallic element to be used for Eddy-current damping will interfere and distort the otherwise weak operating magnetic field. Moreover, introduction of any external permanent magnet for the purpose of Eddy-current damping will severely hamper the operating magnetic field.

4. Shielding System

The operating field produced by the fixed coils, is comparatively lower in electro-dynamometer-type instruments as compared to other type of instruments. In some cases, even the earth's magnetic field can pollute the measurement readings. It is thus essential to shield the electro-dynamometer-type instruments from effects of external magnetic fields. Enclosures of such instruments are thus made of alloys with high permeability to restrict penetration of external stray magnetic fields into the instrument.

Operation of Electrodynamicometer-type Wattmeter

The instantaneous torque of the electrodynamicometer wattmeter is given by

$$T_i = i_p i_c \frac{dM}{d\theta}$$

Instantaneous value of voltage across the pressure-coil circuit is

$$v_p = \sqrt{2} \times V \sin \omega t$$

If the pressure coil resistance can be assumed to be very high, the whole pressure coil can be assumed to be behaving like a resistance only.

The current i_p in the pressure coil thus, can be assumed to in phase with the voltage v_p , and its instantaneous value is

$$i_p = \frac{v_p}{R_p} = \sqrt{2} \times \frac{V}{R_p} \sin \omega t = \sqrt{2} \times I_p \sin \omega t$$

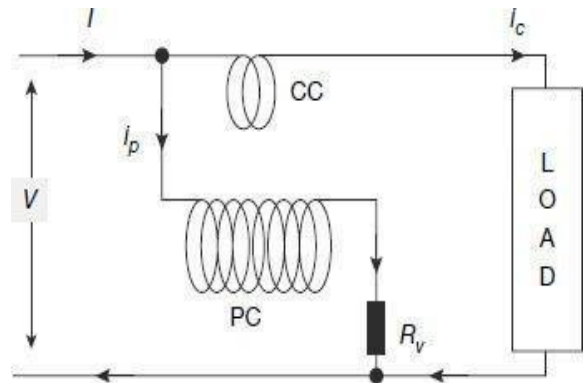

Where, $I_p = V/R_p$ is the rms value of current in pressure coil.

Assuming that the pressure-coil resistance is sufficiently high to prevent branching out of any portion of the supply current towards the pressure coil, the current coil current can be written as

$$i_c = \sqrt{2} \times I \sin(\omega t - \phi)$$

Thus, instantaneous torque can be written as

$$\begin{aligned} T_i &= \sqrt{2} \times I_p \sin \omega t \times \sqrt{2} \times I \sin(\omega t - \phi) \frac{dM}{d\theta} \\ &= 2I_p I \sin \omega t \sin(\omega t - \phi) \frac{dM}{d\theta} \\ &= I_p I \{ \cos \phi - \cos(2\omega t - \phi) \} \frac{dM}{d\theta} \end{aligned}$$

Presence of the term containing $2\omega t$, indicates the instantaneous torque varies at twice the frequency of voltage and current.

Average deflecting torque over a complete cycle is

$$\begin{aligned} T_d &= \frac{1}{T} \int_0^T T_i d\omega t = \frac{1}{2\pi} \int_0^{2\pi} I_p I \{ \cos \phi - \cos(2\omega t - \phi) \} \frac{dM}{d\theta} d\omega t \\ &= \frac{I_p I}{2\pi} [\omega t \cos \phi]_0^{2\pi} \frac{dM}{d\theta} \\ &= I_p I \cos \phi \frac{dM}{d\theta} \\ &= \frac{V}{R_p} I \cos \phi \frac{dM}{d\theta} \\ &= \frac{VI \cos \phi}{R_p} \frac{dM}{d\theta} \end{aligned}$$

With a spring constant K , the controlling torque provided by the spring for a final steady-state deflection of θ is given by

$$T_C = K\theta$$

Under steady-state condition, the average deflecting torque will be balanced by the controlling torque provided by the spring. Thus, at balanced condition $T_C = T_d$

$$\begin{aligned} T_C &= T_d \\ K\theta &= \frac{VI \cos \phi}{R_p} \frac{dM}{d\theta} \\ \theta &= \frac{VI \cos \phi}{KR_p} \frac{dM}{d\theta} \\ \theta &= \left(K_1 \frac{dM}{d\theta} \right) P \end{aligned}$$

where, P is the power to be measured and $K_1 = 1/KR_p$ is a constant.

Steady-state deflection θ is thus found to be an indication of the power P to be measured.

INDUCTION-TYPE WATTMETER

Induction-type wattmeters, however, following the very basic principles of mutual induction, can only be used for measurement of ac power, in contrast to electro-dynamometer type wattmeters that can be used for power measurements in both ac and dc circuits. Induction type wattmeters, in contradiction to electro-dynamometer-type wattmeters, can be used only with circuits having relatively steady values of frequency and voltage.

Construction of Induction-type Wattmeter

Induction-type wattmeters have two laminated iron-core electromagnets. One of the electromagnets is excited by the load current, and the other by a current proportional to the voltage of the circuit in which the power is to be measured. The upper magnet in **e** which is connected across the voltage to be measured, is named as the *shunt* magnet, whereas the other electromagnet connected in series with the load to carry load current is called the *series* magnet. A thin aluminum disc, mounted in the space between the two magnets is acted upon by a combined effect of fluxes coming out of these two electromagnets. In ac circuits, interaction of these changing fluxes will induce Eddy-current within the aluminum disc.

The two voltage coils, connected in series, are wound in such a way that both of them send flux through the central limb. Copper shading bands fitted on the central limb of the shunt magnet makes the flux coming out of the magnet lag behind the applied voltage by 90° .

The series magnet houses two small current coils in series. These are wound in a way that the fluxes they create within the core of the magnet are in the same direction.

Operation of Induction-type Wattmeter

V = voltage to be

measured I = current

to be measured

= phase-angle lag of current I with respect to voltage V

ϕ_{sh} = flux of the shunt magnet

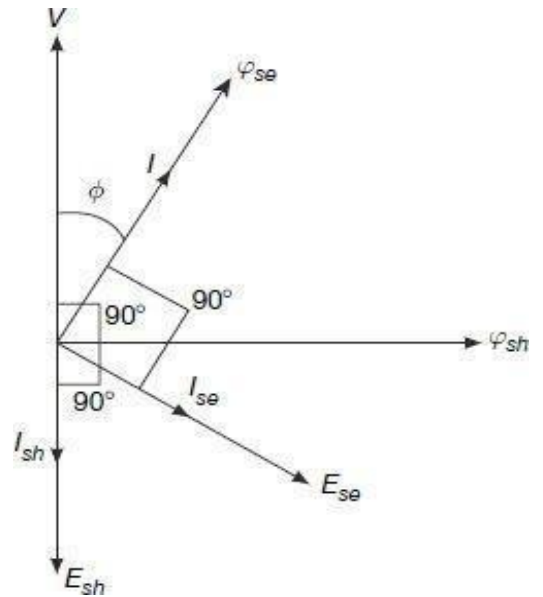

The shunt magnet flux ϕ_{sh} is made to lag behind the applied voltage (V) by 90° .

This is achieved by the use of copper shading rings.

On the other hand, the series magnet flux ϕ_{se} is in the same phase as the load current (I) through it.

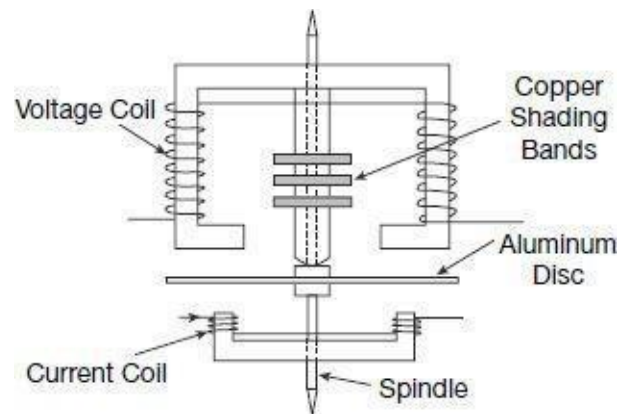

The instantaneous torque acting on the aluminum disc is proportional to $(\phi_{sh} \cdot i_{se} - \phi_{se} \cdot i_{sh})$.

Let, instantaneous value the applied voltage is

$$v = V_m \sin \omega t$$

Then, the instantaneous current is given by

$$i = I_m \sin (\omega t - j)$$

The shunt magnet flux generated is

$$\phi_{sh} = k' \int v \cdot dt = -k' \frac{V_m}{\omega} \cos \omega t$$

where $k\phi$ is a constant and the minus (-) sign indicating the fact the flux ϕ_{sh} lags behind the voltage by 90° .

The series magnet flux generated is

$$\phi_{se} = kI_m \sin(\omega t - \phi)$$

where k is another constant.

The eddy emf induced in the disc due to the shunt magnet flux is

The resultant eddy-current flowing in the disc is

$$I_{sh} = -\frac{k'V_m}{Z} \sin(\omega t - \alpha)$$

where α is the phase-angle of the eddy path impedance (Z).

Similarly, the eddy emf induced in the disc due to the series magnet flux is

$$E_{se} = -\frac{d\phi_{se}}{dt} = -kI_m \omega \cos(\omega t - \phi) a$$

The resultant Eddy-current flowing in the disc is

$$I_{se} = -\frac{kI_m}{Z} \omega \cos(\omega t - \phi - \alpha)$$

The instantaneous deflecting torque (T) acting on the disc can now be calculated as

$$T = \frac{kk'}{Z} V_m I_m [\cos \omega t \cos(\omega t - \phi - \alpha) + \sin(\omega t - \phi) \sin(\omega t - \alpha)]$$

The average torque acting on the disc is thus

$$\begin{aligned} T_d &= \frac{1}{2\pi} \int_0^{2\pi} \frac{kk'}{Z} V_m I_m [\cos \omega t \cos(\omega t - \phi - \alpha) + \sin(\omega t - \phi) \sin(\omega t - \alpha)] dt \\ &= \frac{kk'}{Z} V_m I_m \frac{1}{2} [\cos(\phi + \alpha) + \cos(\phi - \alpha)] \\ &= \frac{kk'}{Z} V_m I_m \cos \alpha \cos \phi \\ &= \left(\frac{2kk'}{Z} \cos \alpha \right) VI \cos \phi \end{aligned}$$

where, V and I are rms values of voltage and current. Average torque on the instrument is thus found to be proportional to the power in the circuit.

TOPIC-4

ENERGY METERS AND MEASUREMENT OF ENERGY

Energy is the total power consumed over a time interval, that is $\text{Energy} = \text{Power} \times \text{Time}$. Generally, the process of measurement of energy is same as that for measurement of power except for the fact that the instrument used should not merely measure power or rate of consumption of energy, but must also take into account the time interval during which the power is being supplied.

The unit of energy can be expressed in terms of Joule or Watt-second or Watt-hour as per convenience. A larger unit that is most commonly used is kilowatt-hour (kWh), which is defined as the energy consumed when power is delivered at an average rate of 1 kilowatt for one hour. In commercial metering, this amount of 1 kilowatt-hour (kWh) energy is specified as 1 unit of energy.

Energy meters used for measurement of energy have moving systems that revolve continuously, unlike in indicating instruments where it deflects only through a fraction of a revolution. In energy meters, the speed of revolution is proportional to the power consumed. Thus, total number of revolutions made by the meter moving system over a given interval of time is proportional to the energy consumed. In this context, a term called meter constant, defined as the number of revolutions made per kWh, is used. Value of the meter constant is usually marked on the meter enclosure.

SINGLE-PHASE INDUCTION-TYPE ENERGY METER

Induction-type instruments are most commonly used as energy meters for measurement of energy in domestic and industrial ac circuits. Induction-type meters have lower friction and higher torque/weight ratio; they are inexpensive, yet reasonably accurate and can retain their accuracy over considerable range of loads and temperature.

Basic Theory of Induction-type Meters

In all induction-type instruments, two time-varying fluxes are created in the windings provided on the static part of the instrument. These fluxes are made to link with a metal disc or drum and produce emf therein. These emfs in turn, circulate eddy current on the body of the metal disc. Interaction of these fluxes and eddy currents produce torques that make the disc or drum to rotate.

A thin aluminum disc free to rotate about its central axis is fitted with a spindle and placed below the two poles ϕ_1 and ϕ_2 . Fluxes ϕ_1 and ϕ_2 coming out of the two electromagnets ϕ_1 and ϕ_2 link with the aluminum disc placed below. These fluxes are alternating in nature, and hence they induce emfs in the aluminum disc. These induced emfs will in turn produce eddy currents i_1 and i_2

on the disc. There are two sets of fluxes ϕ_1 and ϕ_2 , and two sets of currents i_1 and i_2 . Current i_1 interacts with flux ϕ_2 to produce a force F_1 and hence a torque T_{d1} on the disc. Similarly,

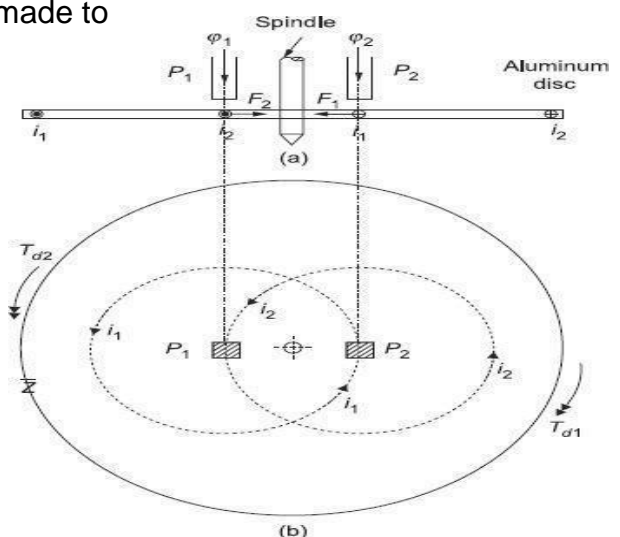

current i_2 interacts

with flux ϕ_1 to produce a force F_2 and hence a torque T_{d2} on the disc. Total torque is resultant of the torques T_{d1} and T_{d2} .

Let ϕ_1 and ϕ_2 are the instantaneous values of two fluxes having a phase difference of α between them.

Therefore, we can write

$$\phi_1 = \phi_m = \phi_{1m} \sin \omega t$$

and
$$\phi_2 = \phi_{2m} \sin(\omega t - \alpha)$$

where, ϕ_{1m} and ϕ_{2m} are peak values of fluxes ϕ_1 and ϕ_2

respectively. The flux ϕ_1 will produce an alternating emf in the disc, given by

$$e_1 = -\frac{d\phi_1}{dt} = -\frac{d}{dt}(\phi_{1m} \sin \omega t) = -\phi_{1m} \omega \cos \omega t$$

Similarly, the alternating emf produced in the disc due to the flux ϕ_2 is given by

$$e_2 = -\phi_{2m} \omega \cos(\omega t - \alpha)$$

If, \bar{Z} is considered to be the impedance of the aluminum disc with power factor β then eddy current induced in the disc due to the emf e_1 can be expressed as

$$i_1 = \frac{e_1}{\bar{Z}} = -\frac{\phi_{1m} \omega \cos(\omega t - \beta)}{\bar{Z}}$$

Similarly, eddy current induced in the disc due to the emf e_2 is given by

$$i_2 = \frac{e_2}{\bar{Z}} = -\frac{\phi_{2m} \omega \cos(\omega t - \alpha - \beta)}{\bar{Z}}$$

Instantaneous torque developed is proportional to the product of instantaneous current and instantaneous flux are those that interact with each other to produce the torque in question.

Instantaneous torque T_{d1} produced due to interaction of the current i_1 and flux ϕ_2 is given by

$$T_{d1} \propto \phi_2 i_1$$

Similarly, instantaneous torque T_{d2} produced due to interaction of the current i_2 and flux ϕ_1 is given by

$$T_{d2} \propto \phi_1 i_2$$

Total deflecting torque can thus be calculated as

$$T_d \propto T_{d1} - T_{d2} \propto \phi_2 i_1 - \phi_1 i_2$$

$$T_d \propto \left[\begin{array}{l} \{\phi_{2m} \sin(\omega t - \alpha)\} \times \left\{ -\frac{\phi_{1m} \omega \cos(\omega t - \beta)}{Z} \right\} \\ - \{\phi_{1m} \sin \omega t\} \times \left\{ -\frac{\phi_{2m} \omega \cos(\omega t - \alpha - \beta)}{Z} \right\} \end{array} \right]$$

$$T_d \propto \frac{\phi_{1m} \phi_{2m} \omega}{Z} [\sin \omega t \cos(\omega t - \alpha - \beta) - \sin(\omega t - \alpha) \cos(\omega t - \beta)]$$

$$T_d \propto \frac{\phi_{1m} \phi_{2m} \omega}{Z} \cdot \frac{1}{2} [\sin(\omega t + \omega t - \alpha - \beta) + \sin(\omega t - \omega t + \alpha + \beta) \\ - \sin(\omega t - \alpha + \omega t - \beta) - \sin(\omega t - \alpha - \omega t + \beta)]$$

$$T_d \propto \frac{\phi_{1m} \phi_{2m} \omega}{Z} \cdot \frac{1}{2} [\sin(2\omega t - \alpha - \beta) + \sin(\alpha + \beta) \\ - \sin(2\omega t - \alpha - \beta) - \sin(\beta - \alpha)]$$

$$T_d \propto \frac{\phi_{1m} \phi_{2m} \omega}{Z} \cdot \frac{1}{2} [\sin(\alpha + \beta) - \sin(\beta - \alpha)]$$

$$T_d \propto \frac{\phi_{1m} \phi_{2m} \omega}{Z} \cdot \frac{1}{2} [\sin \alpha \cos \beta + \cos \alpha \sin \beta - \sin \beta \cos \alpha + \cos \beta \sin \alpha]$$

$$T_d \propto \frac{\phi_{1m} \phi_{2m} \omega}{Z} \cdot \sin \alpha \cos \beta \quad (8.1)$$

The following two observations can be made:

- The torque is directly proportional to the power factor of the aluminum disc ($\cos \beta$). Thus, to increase the deflecting torque, the path of eddy current in the disc must be as resistive as possible, so that value of $\cos \beta$ is as high as possible.
- The torque is directly proportional to $\sin \alpha$. Therefore, to have large deflecting torque, the angle α between the two fluxes should preferably be as nearly as possible close to 90° .

Constructional Details of Induction-Type Energy Meter

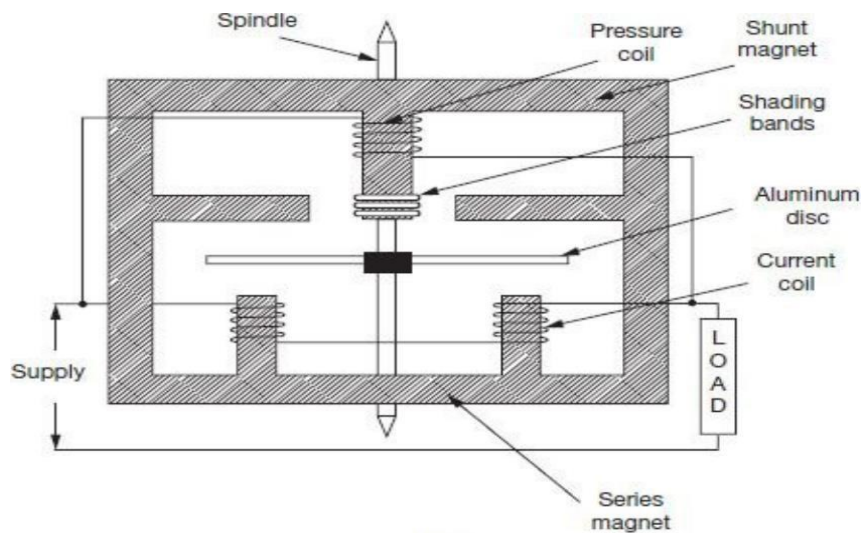

Volatagecoil—many turns of fine wire encased in plastic, connected in parallel with load. **Current coil**—few turns of thick wire, connected in series with load **Stator**—concentrates and confines magnetic field.

Aluminum rotor disc.

Rotor brake magnets

Spindle with worm gear.

Display dials

A single phase energy meter has four essential parts:

1. Operating system
2. Moving system
3. Braking system
4. Registering system

1. Operating System

The operating system consists of two electromagnets. The cores of these electromagnets are made of silicon steel laminations. The coils of one of these electromagnets (series magnet) are connected in series with the load, and is called the current coil. The other electromagnet (shunt magnet) is wound with a coil that is connected across the supply, called the pressure coil. The pressure coil, thus, carries a current that is proportional to supply voltage.

Shading bands made of copper are provided on the central limb of the shunt magnet. Shading bands, as will be described later, are used to bring the flux i — Bearing produced by a shunt magnet exactly in quadrature Pivot with the applied voltage.

2. Moving System

The moving system consists of a light aluminum disc mounted on a spindle. The disc is placed in the space between the series and shunt magnets. The disc is so positioned that it intersects the flux produced by both the magnets. The deflecting torque on the disc is produced by interaction between these fluxes and the eddy current they induce in the disc. In energy meters, there is no control spring as such, so that there is continuous rotation of the disc.

3. Braking System

The braking system consists of a braking device which is usually a permanent magnet positioned near the edge of the aluminum disc.

The emf induced in the aluminum disc due to relative motion between the rotating disc and the fixed permanent magnet (brake magnet) induces eddy current in the disc. This eddy current, while interacting with the brake magnet flux, produces a retarding or braking torque. This braking torque is proportional to speed of the rotating disc. When the braking torque becomes equal to the operating torque, the disc rotates at a steady speed. The position of the permanent magnet with respect to the rotating disc is adjustable. Therefore, braking torque can be adjusted by shifting the permanent magnet to different radial positions with respect to the disc.

4. Registering System

The function of a registering or counting system is to continuously record a numerical value that is proportional to the number of revolutions made by the rotating system. By suitable combination of a train of reduction gears, rotation of the main aluminum disc can be transmitted to different pointers to register meter readings on different dials. Finally, the kWh reading can be obtained by multiplying the number of revolutions as pointed out by the dials with the meter constant.

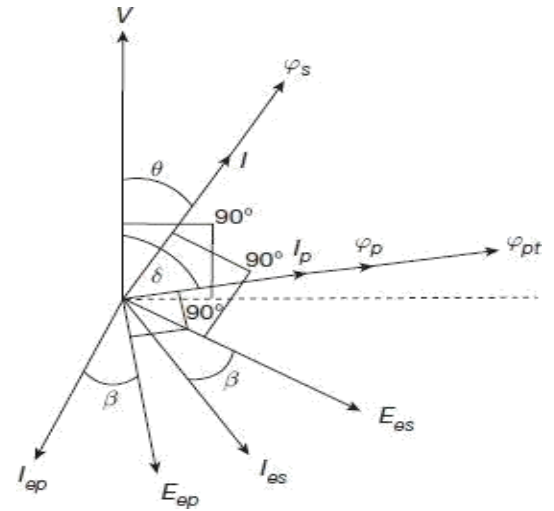

Operation of Induction-Type Energy Meter

As per construction, the pressure coil winding is made highly inductive by providing a large number of turns. The air gaps in a shunt magnet circuit are also made small to reduce the reluctance of shunt flux paths. Thus, as supply voltage is applied across the pressure coil, the current I_p through the pressure coil is proportional to the supply voltage and lags behind it by an angle that is only a few degrees less than 90° . Ideally, this angle of lag should have been 90° but for the small unavoidable resistance present in the winding itself and the associated iron losses in the magnetic circuit.

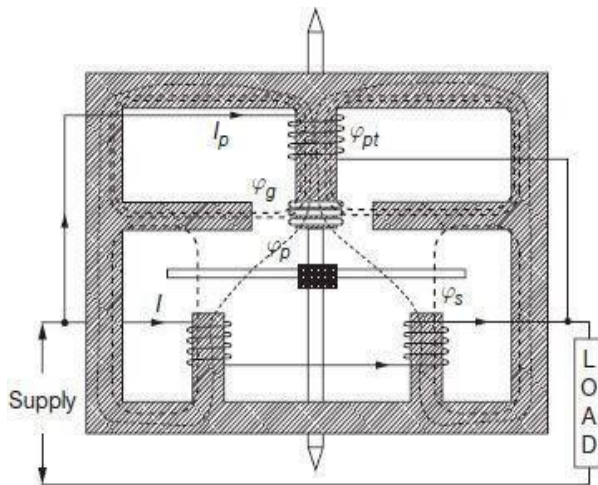

Let, V = supply

voltage I = load

current

θ = phase angle of load

β = phase angle of aluminum disc

= phase angle between shunt magnet and series magnet

fluxes δ = phase angle between supply voltage and pressure coil flux

The current I_P produces a flux ϕ_{pt} that is in same phase as I_P . This flux is made to divide itself in two parts, ϕ_g and ϕ_p . The major portion of total pressure coil flux, i.e., ϕ_g passes through the side gaps, as reluctance of these paths are low due very small air gaps. Remaining portion of the flux, i.e., ϕ_p passes through the disc and is responsible for production of the driving torque. Due to larger reluctance of the path, this flux ϕ_p is relatively weaker.

The flux ϕ_p is proportional to the current I_P and is in the same phase. The flux ϕ_p is thus proportional to the supply voltage V and lags it by an angle δ which is only a few degrees less than 90° . The flux ϕ_p being alternating in nature, induces an eddy emf E_{ep} in the disc, which in turn produces eddy current

I . Depending on the impedance angle β of the aluminum disc, eddy current I will lag behind the eddy emf E_{ep} by an angle β .

The load current I flows through the series magnet current coil and produces a flux ϕ_s . This flux is proportional to the load current I and is in phase with it. This flux, in the same way, induces an eddy emf E_{es} in the disc, which in turn produces eddy current I_{es} . The eddy current I_{es} lags behind the eddy emf E_{es} by the same angle β .

Now, the eddy current I_{es} interacts with flux ϕ_p to produce a torque and the eddy current I_{ep} interacts with flux ϕ_s to produce another torque. These two torques are in opposite direction, and the resultant torque is the difference of these two.

The resultant deflecting torque on the disc due to combined action of two fluxes ϕ_p and ϕ_s is given as

$$T_d \propto \frac{\phi_p \phi_s \omega}{r} \cdot \sin \alpha \cos \beta$$

Where, Z is the impedance of the aluminum disc and ω is the angular frequency of supply voltage. The driving torque can be re-written following the phasor diagram as

$$T_d = K_1 \frac{\phi_p \phi_s \omega}{Z} \cdot \sin(\delta - \theta) \cos \beta, \text{ where } K_1 \text{ is a constant}$$

Since we have, $j_{pc} = V$ and $\phi_{sc} = I$,

$$\therefore \text{ driving torque } T_d = K_2 VI \frac{\omega}{Z} \cdot \sin(\delta - \theta) \cos \beta$$

If ω , Z and β are constants, then $T_d = K_3 VI \sin(\delta - \theta)$

If N is the speed of rotation of the disc, then braking torque $T_b = K_4 N$

At steady running condition of the disc, the driving torque must equal the braking torque,

$$\therefore K_4 N = K_3 VI \sin(\delta - \theta)$$

$$\text{or, } N = KVI \sin(\delta - \theta)$$

If we can make $\delta = 90^\circ$

$$\text{Then speed of disc is } N = KVI \sin(90^\circ - \theta) = KVI \cos \theta$$

$$\text{Thus speed } N = K \times \text{Power}$$

Thus, in order that the speed of rotation can be made to be proportionate to the power consumed, the angle difference δ between the supply voltage V and the pressure coil flux ϕ_p must be made 90° .

Total number of revolutions within a time interval dt is

$$\begin{aligned} &= \int N dt = \int KVI \sin(\delta - \theta) dt \\ &= K \int VI \cos \theta dt \\ &= K \int (\text{power}) \times dt \\ &= K \times \text{Energy} \end{aligned}$$

If, $\epsilon = 90^\circ$, total number of revolutions

Thus, total number of revolutions is proportional to the energy consumed.

ERRORS IN INDUCTION-TYPE ENERGY METERS AND THEIR COMPENSATION

Phase-angle Error

The meter will indicate true energy only if the phase angle between the pressure coil flux ϕ_p and the supply voltage V is 90° . This requires that the pressure coil winding should be designed as highly inductive and its resistance and iron losses should be made minimum. But, even then the phase angle is not exactly 90° , rather a few degrees less than 90° . Suitable adjustments can be implemented such

that the shunt magnet flux linking with the disc can be made to lag the supply voltage by an angle exactly equal to 90° .

1. Shading Coil with Adjustable Resistance

This is the arrangement where an additional coil (shading coil) with adjustable resistance is placed on the central limb of the shunt magnet close to the disc. Main flux created by the shunt magnet induces an emf in this shading coil. This emf creates its own flux. These two fluxes result in a modified flux to pass through the air gap to link the disc and thus produce the driving torque. With proper adjustment of the shading coil resistance, the resultant flux can be made to lag the supply voltage exactly by an angle of 90° .

The pressure coil, when excited from the supply voltage V , carries a current I_p and produces an mmf AT_{pt} which in turn produces the total flux ϕ_{pt} . The flux ϕ_{pt} lags the supply voltage V by an angle ϕ which is slightly less than 90° . The current I_p produces a flux ϕ_{pt} that is in same phase as I_p . The flux ϕ_{pt} gets divided in two parts, ϕ and ϕ_p . The portion of flux ϕ passes through the side gaps, and remaining portion of the flux, i.e., ϕ_p passes through the disc and also the shading coil. Due to linkage with the time varying flux, an emf E_{sc} is induced in the shading coil that lags behind its originating flux ϕ_p by 90° (i.e. E_{sc} is 180°) lagging behind the supply voltage V . This emf circulates and eddy current I_{sc} through the shading coil itself. I_{sc} lags behind the emf E_{sc} by an angle λ that depends on the impedance of the shading coil. The shading coil current I_{sc} produces an mmf AT_{sc} which is in phase with I_{sc} . The flux ϕ_p passing through to the disc will thus be due to the resultant mmf AT_p which is summation of the original mmf AT_{pt} and the mmf AT_{sc} due to the shading coil. This flux ϕ_p will be in phase with the mmf AT_p . The flux ϕ_p can be made to lag the supply voltage V by exactly 90° if the mmf AT_p or in other words, the shading coil phase angle λ can be adjusted properly. The shading coil phase angle can easily be adjusted by varying the external resistance connected to the shading coil.

2. Copper Shading Bands

A similar result of lag adjustment can be obtained by the use of copper shading bands placed on the central limb of the shunt magnet. Such an arrangement is shown in Figure 8.10. Following the same arguments, the resultant flux ϕ_p crossing over to the disc can be made to lag the supply voltage V by exactly 90° by proper adjustment of the mmf produced by the copper shading bands. Adjustments in this case can be done by moving the shading bands along the axis of the limb. As the bands are moved upwards along the limb, they embrace more flux. This results in increased values of induced emf, increased values of induced eddy current and hence increased values of the mmf produced by the bands. Similarly, as the bands are moved downwards, mmf produced

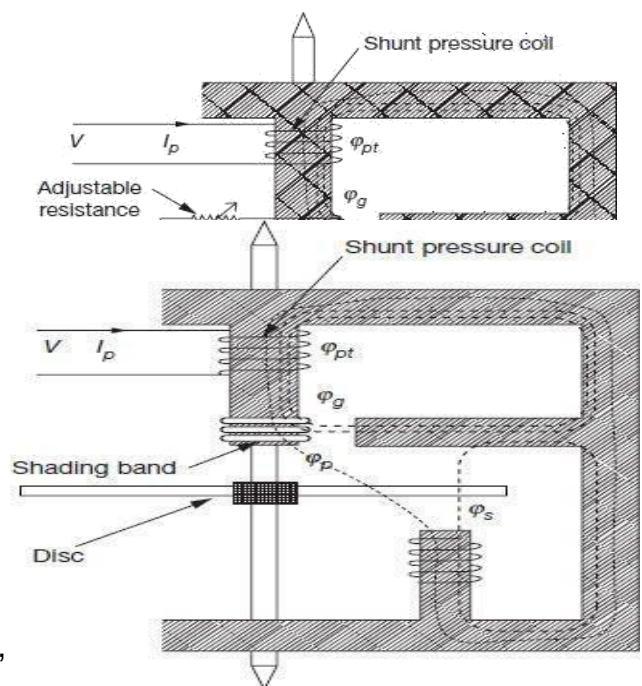

by the bands is reduced. This changes the phase angle difference between ϕ_p and ϕ_{pt} , as can be observed. Thus, careful adjustments of the copper shading bands position can make the phase difference between the supply voltage V and resultant shunt magnet flux ϕ_p to be exactly 90° .

Error due to Friction at Light Loads

Friction in bearings can pose serious errors in measurement of energy in the form of that it will impede proper movement of the rotating disc. This problem is particularly objectionable at low loads, when the driving torque itself is very low; therefore, unwanted friction torque can even stop the disc from rotating. To avoid this, it is necessary to provide an additional torque that is essentially independent of the load, to be applied in the direction of the driving torque, i.e., opposite to the frictional torque to compensate for the frictional retarding torque. This is achieved by means of a small vane or shading loop placed in the air gap between the central limb of the shunt magnet and the aluminum disc, and slightly off-centre from the central limb. Interactions between fluxes which are linked and not linked by the shading or compensating vane and the currents they induce in the disc result in a small driving torque that can compensate for the frictional retarding torque. The value of this small additional torque can be adjusted by lateral movement of the vane in and out of its position in the air gap.

Creeping Error

In some meters, a slow but continuous rotation of the disc can be observed even when there is no current flowing through the current coil, and only pressure coil is energised. This is called **creeping**. The primary reason for creeping is due to over-compensation for friction. Though the main driving torque is absent at no-load, the additional torque provided by the friction compensating vane will make the disc continue to rotate. Other causes of creeping may be excessive voltage across the potential coil resulting in production of excessive torque by the friction compensating device, or vibrations, and stray magnetic fields.

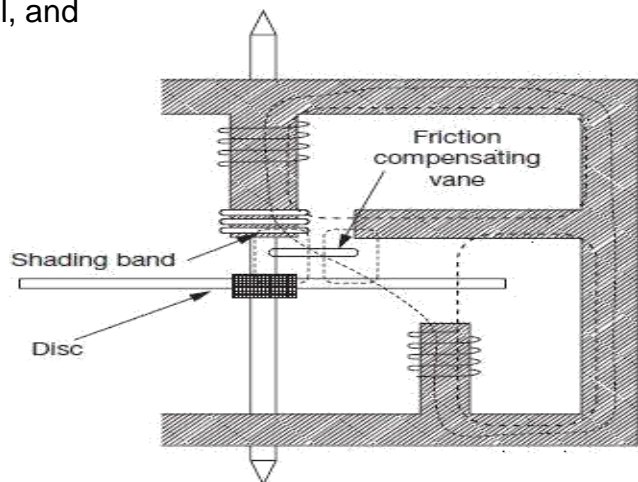

Creeping can be avoided by drilling two holes on the aluminum disc placed on diametrically opposite locations. Drilling such holes will distort the eddy current paths along the disc and the disc will tend to stop with the holes coming underneath the shunt magnet poles. The disc can thus creep only till a maximum of half the rotation till one of the holes comes below the shunt magnet pole. This effect is however, too insignificant to hamper disc movement during normal running operations under load.

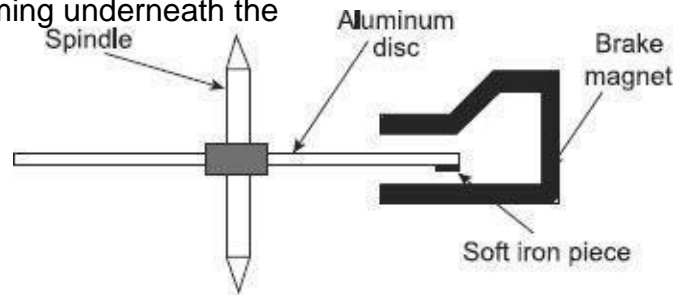

Creeping can also be avoided by attaching a tiny piece of iron to the edge of the disc. The brake magnet in such a case can lock the iron piece to itself and prevent creeping of the disc. Once again, this action is too insignificant to hamper disc movement during normal running operations under load.

Error due to Change in Temperature

Errors introduced by variation of temperature in induction-type energy meters are usually small since the various effects tend to neutralise each other. An increase in temperature increases the pressure coil resistance, thereby reducing pressure coil current and reducing pressure coil flux. This will tend to reduce the driving torque. But the flux of the brake magnet also reduces due to increase in temperature, thereby reducing the braking torque. Again, an increase in temperature increases the resistance to eddy current path in the disc, which reduces both driving torque and braking torque. The various effects thus tend to neutralise each other.

The effects of increasing temperature, however, in general cause the meter to rotate faster and hence record higher values. Temperature effects thus need to be compensated for by using temperature shunts in the brake magnet.

Error due to Overload

At a constant voltage, the deflecting torque becomes simply proportional to the series magnet flux and hence proportional to the load current. This is due to the fact that, at constant voltage as the shunt magnet flux ϕ_p is constant, the driving torque $T_d \propto \phi_s I$.

On the other hand, as the disc rotates continuously in the field of the series magnet, an emf is induced dynamically in the disc due to its linkage with the series magnet flux ϕ_s . This emf induces eddy currents in the disc that interact with the series magnet flux to create a retarding or braking torque that opposes motion of the disc. This self braking torque is proportional to the square of the series magnet flux or is proportional to the

square of the load current; i.e., $T_b \propto \phi_s^2 \propto I^2$.

At higher loads, thus the braking torque overpowers the deflecting torque and the meter tends to rotate at slower speed, and consequently reads lower than actual.

To avoid such errors, and to minimise the self-braking action, the full load speed of the disc is set at lower values. The current coil flux ϕ_s is made smaller as compared to the pressure coil flux ϕ_p . Thus, the dynamically induced emf that causes the braking torque is restricted as compared to the driving torque. Magnetic shunts are also sometimes used with series magnets to compensate for overload errors at high current values.

Error due to Voltage Variations

Voltage variations can cause errors in induction-type energy meters mainly due to two reasons:

At too high voltages, the relationship between the supply voltage V and the shunt magnet flux ϕ_p no longer remain linear due to saturation of iron parts, and For sudden fluctuations in supply voltage, the shunt magnet flux ϕ_p produces a dynamically induced emf in the disc which in turn results in a self-braking torque and the disc rotation is hampered.

Compensation for voltage variation is provided by using a suitable magnetic shunt that diverts a major portion of the flux through the disc when the voltage rises, thereby increasing the driving torque to overcome the self-braking torque. Such compensation can be achieved by increasing the reluctance of the side limbs of the shunt magnet. This is done by providing holes in the side limbs.

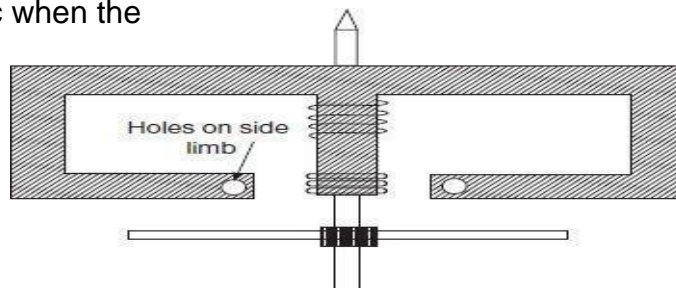

TESTING OF ENERGY METERS

Energy meters are tested at the following conditions:

- At 5% of rated current at unity power factor
- At 100% or 125% of rated current with unity power factor
- At one intermediate load with unity power factor
- At rated current and 0.5 lagging power factor

Creep test With pressure coil supplied with 110% of rated voltage and current coil open circuited, the meter disc should not rotate by more than one revolution, i.e., it should not creep.

Starting test At 0.5% of rated current and full rated voltage, the meter disc should start rotating.

Phantom Loading

When the current rating of the meter under test is high, a test with actual loading arrangements would involve considerable wastage of energy and also it is difficult to arrange for such large loads under laboratory test conditions. In such cases, to avoid this, 'phantom' or 'fictitious' loading arrangements are done for testing of energy meters.

Phantom loading consists of supplying the shunt magnet pressure coil circuit from a rated voltage source. The series magnet current coil is supplied from a separate low voltage supply source. It is possible to circulate rated current through the current coil circuit with the low voltage source since impedance of this circuit is very low. The energy indicated by the meter under phantom loading condition is the same as the energy indication as would have been with a real load. With this arrangement, the total energy consumed for the test is comparatively smaller. The total energy required for the test is that due to the small pressure coil current at rated voltage and small current coil voltage at rated current.

TOPIC - 5

MEASUREMENT OF SPEED, FREQUENCY AND POWER FACTOR

Electrical Tachometer

Definition: The tachometer use for measuring the rotational speed or angular velocity of the machine which is coupled to it. It works on the principle of relative motion between the magnetic field and shaft of the coupled device. The relative motion induces the EMF in the coil which is placed between the constant magnetic field of the permanent magnet. The developed EMF is directly proportional to the speed of the shaft.

Mechanical and electrical are the two types of the tachometer. The mechanical tachometer measures the speed of shaft regarding revolution per minutes.

The electrical tachometer converts the angular velocity into an electrical voltage. The electrical tachometer has more advantages over the mechanical tachometer. Thus it is mostly used for measuring the rotational speed of the shaft.

Depends on the natures of the induced voltage the electrical tachometer is categorized into two types.

1. DC Tachometer Generator
2. AC Tachometer Generator

DC Tachometer Generator

Permanent magnet, armature, commutator, brushes, variable resistor, and the moving coil voltmeter are the main parts of the DC tachometer generator. The machine whose speed is to be measured is coupled with the shaft of the DC tachometer generator.

The DC tachometer works on the principle that when the closed conductor moves in the magnetic field, EMF induces in the conductor. The magnitude of the induced emf depends on the flux link with the conductor and the speed of the shaft.

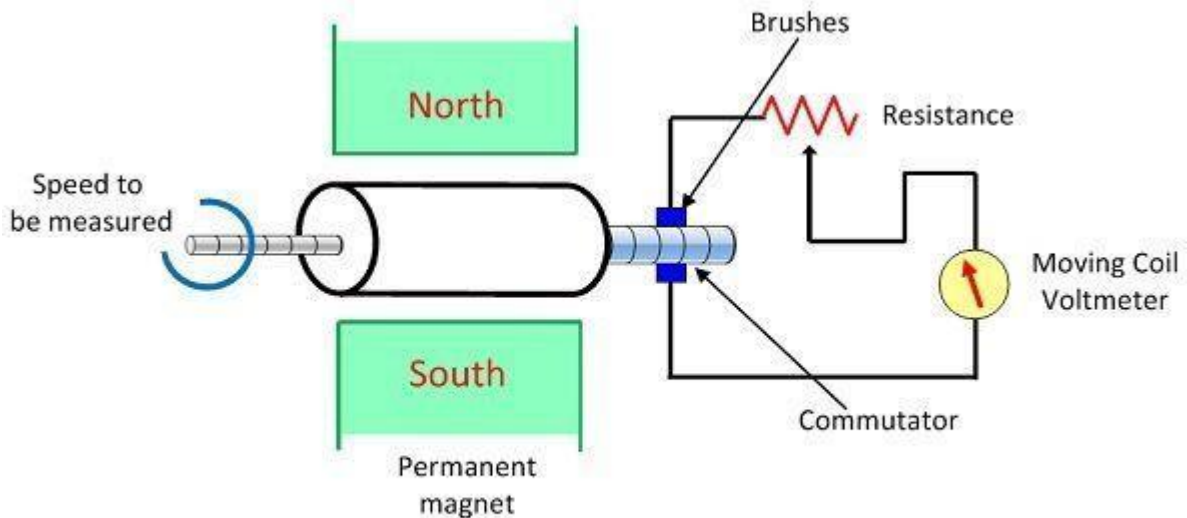

DC Tachometer Generator

The armature of the DC generator revolves between the constant field of the permanent magnet. The rotation induces the emf in the coil. The magnitude of the induced emf is proportional to the shaft speed.

The commutator converts the alternating current of the armature coil to the direct current with the help of the brushes. The moving coil voltmeter measures the induced emf. The polarity of the induced voltage determines the direction of motion of the shaft. The resistance is connected in series with the [voltmeter](#) for controlling the heavy current of the armature.

The emf induces in the dc tachometer generator is given as

$$E = \frac{\Phi P N}{60} \times \frac{z}{a}$$

Where, E – generated voltage

Φ – flux per poles in Weber

P- number of poles

N – speed in revolution per minutes

Z – the number of the conductor in armature windings.

a – number of the parallel path in the armature windings.

Now,

$$E \propto N$$

$$E = KN$$

$$K = \text{Constant} = \frac{\Phi P}{60} \times \frac{z}{a}$$

Advantages:

The following are the advantages of the DC Tachometer.

- The polarity of the induced voltages indicates the direction of rotation of the shaft.
- The conventional DC type voltmeter is used for measuring the induced voltage.

Disadvantages:

- The commutator and brushes require the periodic maintenance.
- The output resistance of the DC tachometer is kept high as compared to the input resistance. If the large current is induced in the armature conductor, the constant field of the permanent magnet will be distorted.

AC Tachometer Generator

The DC tachometer generator uses the commutator and brushes which have many disadvantages. The AC tachometer generator designs for reducing the problems. The AC tachometer has stationary

armature and rotating magnetic field. Thus, the commutator and brushes are absent in AC tachometer generator.

The rotating magnetic field induces the EMF in the stationary coil of the stator. The amplitude and frequency of the induced emf are equivalent to the speed of the shaft. Thus, either amplitude or frequency is used for measuring the angular velocity.

The below mention circuit is used for measuring the speed of the rotor by considering the amplitude of the induced voltage. The induces voltages are rectified and then passes to the capacitor filter for smoothing the ripples of rectified voltages.

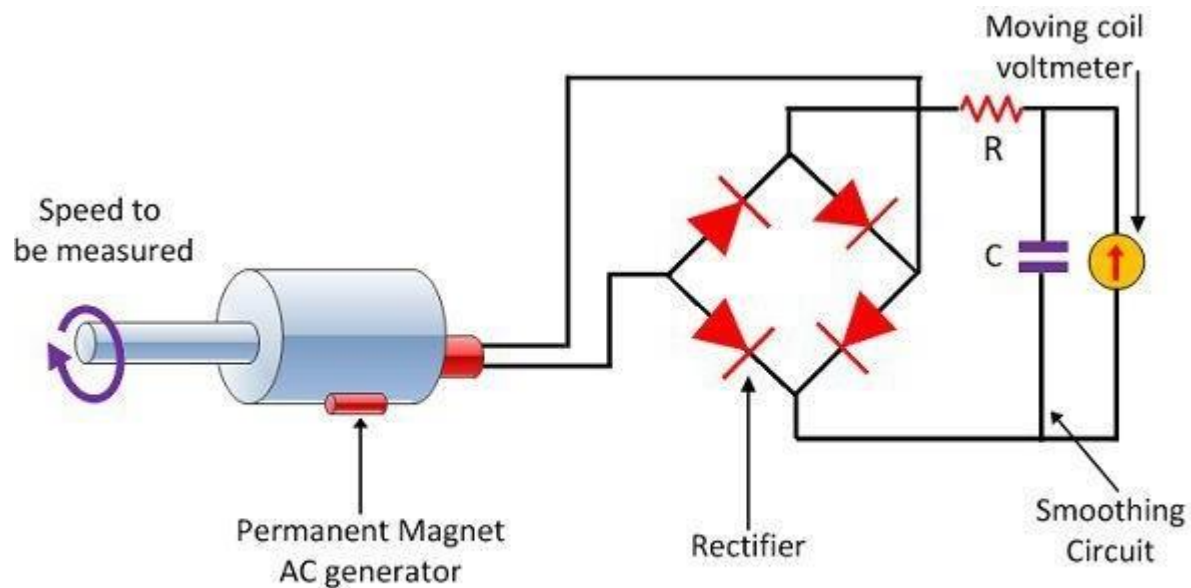

A.C Tachometer Generator

Advantages:

- The drag cup Tachogenerator generates the ripple free output voltage.
- The cost of the generator is also very less.

Disadvantage:

- The nonlinear relationship obtains between the output voltage and input speed when the rotor rotates at high speed.

Electrical Resonance Type Frequency Meter

The electrical resonance type frequency meter is an indicating type instrument. As the name suggests its action depends upon the electrical resonance.

Construction of Electrical Resonance Type Frequency Meter

It mainly consists of a fixed coil and a moving coil. There is a laminated iron core of varying cross-section.



This varying laminated core holds the fixed coil at its one end. Then we connect this fixed coil across the supply mains.

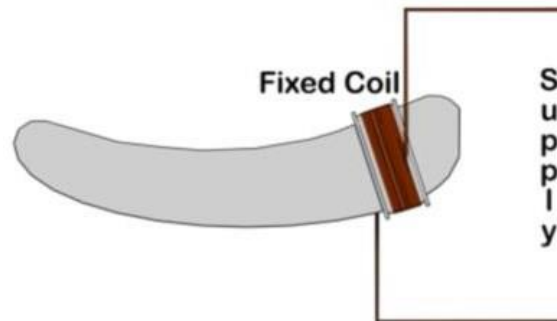

The electrical resonance type frequency meter measures the frequency of these supply mains. Now there is a moving coil which is so pivoted at its top end that it can move along the extended core of the fixed coil like a pendulum. The pointer of the instrument is so attached at the top end of the moving coil that its tip moves along the semicircular dial. Now, we connect on a [capacitor](#) across the two leads of the moving coil.

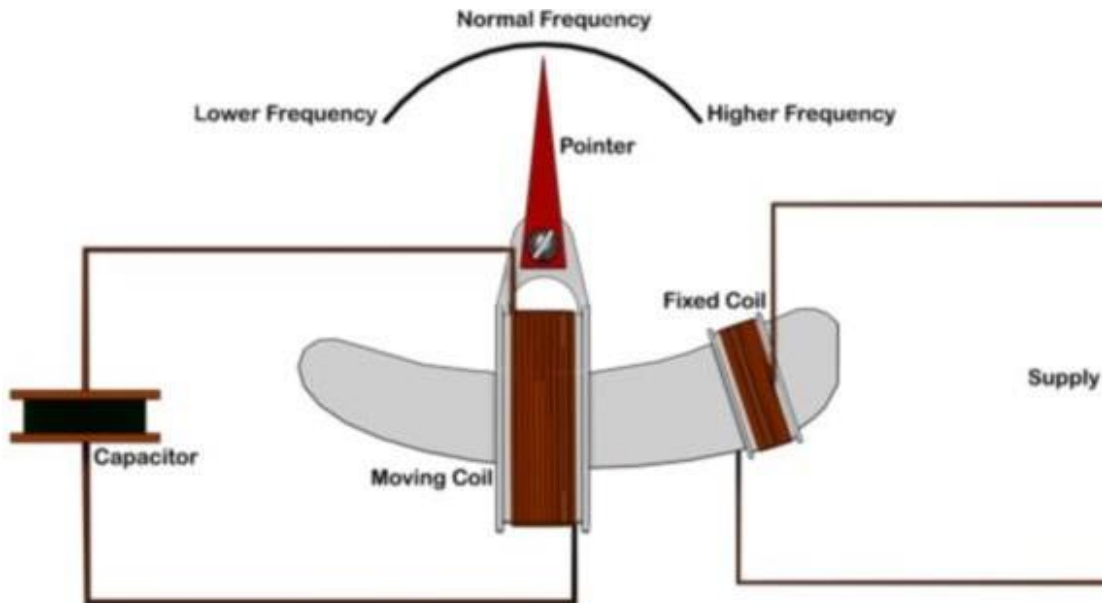

Working Principle of Electrical Resonance Type Frequency Meter

- Due to the current in the moving coil, the moving coil produces a flux in phase with the current.
- This flux flows along with the extended core of the fixed coil. Therefore the flux links the moving coil. Hence, the flux induces an emf across the moving coil. Obviously, this induced emf lags the flux by 90° .
- Since it is a coil; the moving coil will have some inductive [reactance](#). Again, as it is connected across a [capacitor](#), it will have some capacitive reactance also.

Torque Equation

Let us consider I_1 is the supply current of the fixed coil and I_2 is the induced current of the moving coil. Now, we have already mentioned that the phase angle between the supply current I_1 (current in the fixed coil) and the emf induced in the moving coil is 90° . Again there is a phase difference between the induced emf and the induced current I_2 (current in the moving coil).

Let us consider the angle of this phase difference is α . So, the actual phase difference between I_1 and I_2 will be $(90^\circ - \alpha)$. Therefore, we can write the expression of the torque (T) as

$$T \propto I_1 I_2 \cos(90^\circ - \alpha)$$

From the above expression of the torque, we can see that the torque will be zero when α is zero. That means there must not be any phase difference between the induced current and the induced emf in the moving coil.

Resonance: That can only be possible when inductive reactance of the moving coil becomes equal to its capacitive reactance.

- Again the inductive [reactance](#) ($2\pi fL$) depends upon the angular position of the moving coil on the extended core of the fixed coil.

- So, when we just switch on the supply, the fixed coil starts attracting the moving coil towards it. This attraction due to the torque acting on the moving system.
- Therefore, the moving coil starts rotating along with the pointer attached to it. As a result, the inductive **reactance** of the moving coils changes. Then after certain angular rotation of the moving coil the inductive reactance of this coil exactly becomes equal to the capacitive **reactance** of the coil. At that point of time, there will be no torque acting on the moving system of the electrical resonance type frequency meter. Therefore the pointer of the instrument becomes stationary at that point.
- If somehow the supply frequency changes, the value of inductive reactance of the instrument also changes. Therefore the resonance of the circuit gets disturbed. Therefore again the deflecting torque appears on the moving system and tries to rotate it further. Hence, again the inductive reactance of the moving coils changes. And after a certain rotation again resonance occurs. So, here again, the torque becomes zero. Therefore the pointer rests on a new position.
- So, we have seen how the position of the pointer on the dial of electrical resonance type frequency meter changes with changing the supply frequency.
- **Calibration**
- First, we supply an electrical signal of exactly 50Hz to the moving coil. Then we find the exact position of the pointer tip on the dial and make it as 50Hz.
- Then we slowly increase the supply frequency step by step and see the position at each of the steps. And we mark these positions of the pointer on the dial with the corresponding supply frequencies.
- Then we reduce the supply frequency step by step and mark the corresponding positions of the pointer on the dial with corresponding frequencies.

Measurement of Frequency

When we connect the leads of the fixed coil of an electrical resonance type frequency meter with supply mains the position of the pointer on the dial indicates the actual frequency of the supply signal.

Mechanical Resonance Frequency Meter (Vibrating Reed)

Mechanical resonance type frequency meter is principally an electro-mechanical device. Also, we call this instrument the vibrating reed type frequency meter.

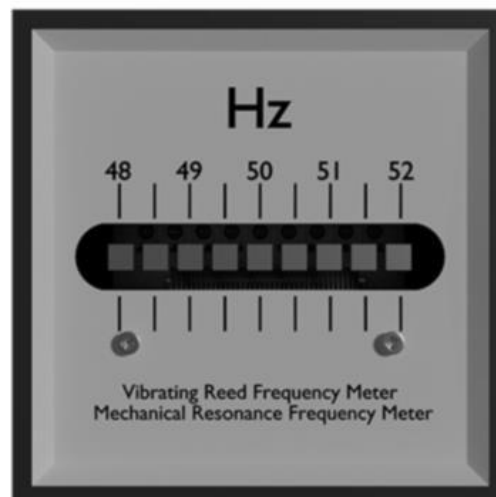

- Conceptually, the principal of this frequency meter is quite simple. The instrument consists of a number of metal reeds with slightly different natural frequencies fitted side by side.
- Also, the instrument consists of an electromagnet placed nearer to these reeds.
- After that, we connect the electromagnet across the supply main. Consequently, there will be an [alternating current](#) flowing through the coil of the electromagnet. Therefore, the electromagnet produces an alternating magnetic flux with the same frequency of supply current.
- The natural frequency of any of the reeds matches to the double of the frequency of the alternating flux. Therefore the resonance occurs at that particular reed. As a result, this particular reed will vibrate with more amplitude than the others. We can see this vibration of that particular reed with our naked eyes.
- Then we can assess that the frequency of the electrical signal coming from the supply main is the same as the natural frequency that vibrating reed.

Construction of Mechanical Resonance Frequency Meter

Mechanical resonance frequency meter (vibrating reed type) consists of a number of reeds. These reeds are of thin steel strips. The front portion of each reed bends with a 90° angle to make better visibility of the mechanical vibration. We fit them in a row with screws at the back end.



- The dimension and weight of all the reeds are not the same. Instead, they differ slightly in each reed from others. This is because for differing the natural frequency of one reed from others.
- Practically this difference of natural frequency from one reed to its adjacent reed is either 1 or 0.5 Hz.
- Suppose we have designed a mechanical resonance frequency meter to measuring a frequency from 48 Hz to 51 Hz. If the difference of natural frequency of any reed from its adjacent reed is 1 Hz, then there will be a total of 9 reeds in the instrument fitted in a row side by side. This is because for the above-mentioned frequency range there will be reeds of natural frequencies from 96 Hz (48×2) to 102 Hz (51×2)

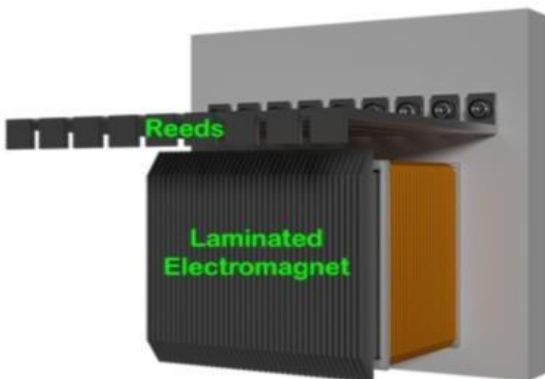

- The instrument also consists of a strong electromagnet with laminated core placed very nearby to the row of the reeds. The coil of the electromagnet has a resistance in series to limit the current in the coil.

Working of Mechanical Resonance Frequency Meter

- When we connect the instrument with the supply main, the electromagnet sets up an alternating flux surround it.
- Due to this alternating flux, the reeds experience an alternating force for every half cycle of the flux wave. This is because when the flux will have a positive half cycle, the steel reeds will get attracted because of the opposite magnetic polarity of the electromagnet induced on the reeds.
- Again during the negative half cycle of the flux wave, the magnetic polarity of the electromagnet is reversed. Then also there will be opposite magnetic polarity induced in the reed in respect of that of the electromagnet. Hence again the reeds get attracted by the electromagnet.
- So, for both negative and positive half cycles, the electromagnet attracts the steel reeds.

But there will be a particular reed whose natural frequency is double of the supply frequency. Therefore mechanical resonance occurs on that reed. Therefore the reed will vibrate most with the highest amplitude. As a result, the vibration of this reed will be easily visible. Hence, the supply frequency will be half of the natural frequency of that reed.

Although due to the alternating flux of the electromagnet all other reed will vibrate. But their vibration is so slight it cannot be visible easily.

In some occasions there may be two adjacent reeds vibrate strongly with equal amplitude. In that case, the supply frequency will be half of the average of the natural frequencies of these two adjacent reeds.

Advantages of Vibrating Reed Type Frequency Meter

- The indication of the frequency of an electrical signal does not depend on the pattern of the waveform of the signal.
- The indication also does not depend on the magnitude of the signal waveform. Only it requires a sufficiently large amplitude for visible reed vibration.

Disadvantage of Mechanical Resonance Frequency Meter

- The instrument cannot indicate properly a frequency which is in between 0.5 precision.

Power Factor Meters

The [power factor](#) of a circuit can be found out from the wattmeter reading and voltmeter and ammeter readings suitably connected in the circuit.

Power factor = Wattmeter reading / (Voltmeter reading x ammeter reading).

Power factor = True Power / Apparent Power

This method involves mathematical calculations. Sometimes it is required to measure the [power factor](#) of the circuit instantaneously when the power factor of the load is varying continuously.

This purpose is served by connecting a dynamometer type power factor meter in the circuit. It indicates the power factor of the circuit directly on the scale by the deflection of a pointer.

Now there are two types of power factor meters-

1. Electro-dynamometer type
2. Moving iron type.

Electro-dynamometer Type Power Factor Meter

In **electro-dynamometer type power factor meter** there are further two types on the basis of supply voltage

1. Single phase
2. Three phase.

Single Phase Power Factor Meter

The basic **working principle of power factor meter** is similar to that of dynamometer type wattmeter i.e. when the field produced by moving system tries to come in line with the field produced by the fixed coil, deflecting torque is exerted on the moving system which deflects the pointer attached to it (the moving system).

Construction of a Power Factor Meter

A dynamometer type power factor meter consists of two fixed coils FF connected in series carrying the load current (or a definite fraction of it) forming the current circuit, and two identical moving coils A and B fixed at the nearly right angle to each other pivoted on the same spindle forming the pressure circuit as shown in the figure.

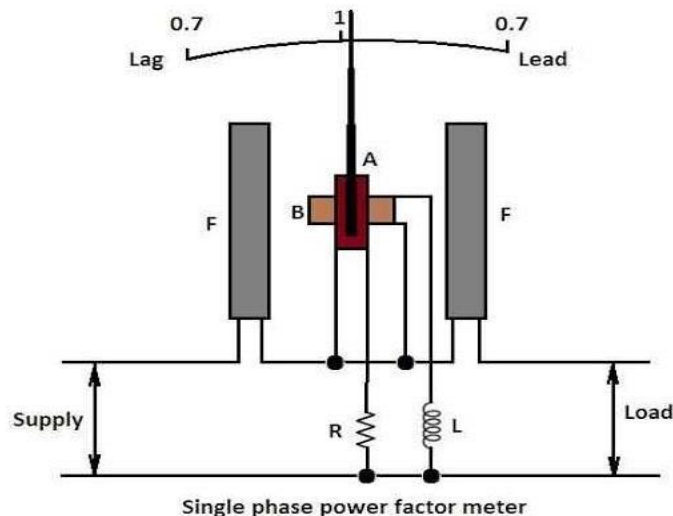

The current coils FF are wound with thick wire whereas pressure coils A and B are wound with fine wire. The pressure coils fixed on the same spindle, to which a pointer is attached, constitutes the moving system.

The pressure coil A is connected across the supply through a non-inductive resistant and pressure coil B is connected across the supply through highly inductive choke coil of inductance L . The value of

resistance R and inductance L are so chosen that for the main supply frequency, the current in the two pressure coils A and B is the same.

Thus the fields produced by the two coils are of the same strength. The field produced by the coil B lags behind the field produced by the coil A slightly less than 90° because of resistance of the coil. Accordingly while fixing the coil B the plane of this coil is displaced from the plane of the coil A by the electrical angle which is slightly less than 90° .

However while discussing the action (working) of the instrument it will be assumed that the phase difference between the two currents flowing through the coils A and B is 90° and same is the angle between the planes of the coils.

Though power factor meter is an indicating instrument but no controlling torque is provided in this instrument. The currents are being led into the moving coils A and B by fine ligaments which exert no control.

Power Factor Meter Working

Since no controlling torque is provided in this instrument, therefore, when it is not connected in the circuit, the moving coils will remain in the position in which these are turned. This will only happen when the moving system is perfectly balanced.

When the instrument is connected to the load circuit, current flows through the fixed coils FF and Moving coils A and B , flux is set by the fixed coils and moving coils.

By the alignment of two fields, torque develops i.e. the resultant field produced by the moving coils tries to come in line with the field produced by the fixed coils and torque develops till both of them come in line with each other.

There are three extreme conditions in which this instrument is connected in the circuit.

1. **When power factor of the circuit is unity:** In this case, current is in phase with circuit voltage. The current flowing through potential coil A is in phase with the voltage which is also in phase with the current flowing through current coil FF .

At the same time, the current flowing through potential coil B lags behind voltage as well as the current flowing through current coil FF by 90° . Thus pressure coil A will experience a turning moment so its plane will come in position a parallel to the plane of the current coil FF . The torque acting on the pressure coil B is zero. Thus, the pointer indicates unity power factor on the scale.

2. **When power factor of the circuit is zero lagging:** In this case, current lags behind the circuit voltage by 90° . Therefore, the current flowing through pressure coil B will be in phase with the current in current coils FF , both being lagging behind the circuit voltage by 90° .

The current flowing through pressure coil A will lead the current in current coil FF by 90° . Thus a turning moment acts on the pressure coil B and brings its plane parallel to the plane of current coil FF and pointer indicates zero power factor lagging.

3. **When power factor of the circuit is zero leading:** In this case current leads the circuit voltage by 90° . Therefore, the current flowing through pressure coil *A* lags the current in current coil *FF* by 90° and the current flowing through pressure coil *B* lags the current in current coil *FF* by 180° .

Thus field produced by the moving system is just reversed to that in the case (2). Thus an opposite turning moment acts on the pressure coil *B* and brings its plane parallel to the plane of current coil *FF* and pointer indicates zero power factor leading.

For intermediate power factors the moving system of power factor meter takes up intermediate positions and the pointer indicates the power factor accordingly.

3 Phase Power Factor Meter

A dynamometer type three-phase power factor meter gives correct readings only when the load is balanced. The basic principle of this instrument is the same as that of the single-phase dynamometer type power factor meter. The only difference is in its construction.

Construction of a 3 Phase Power Factor Meter

It consists of two fixed coils *FF* connected in series in one of the phases and carries the line current as shown in the figure.

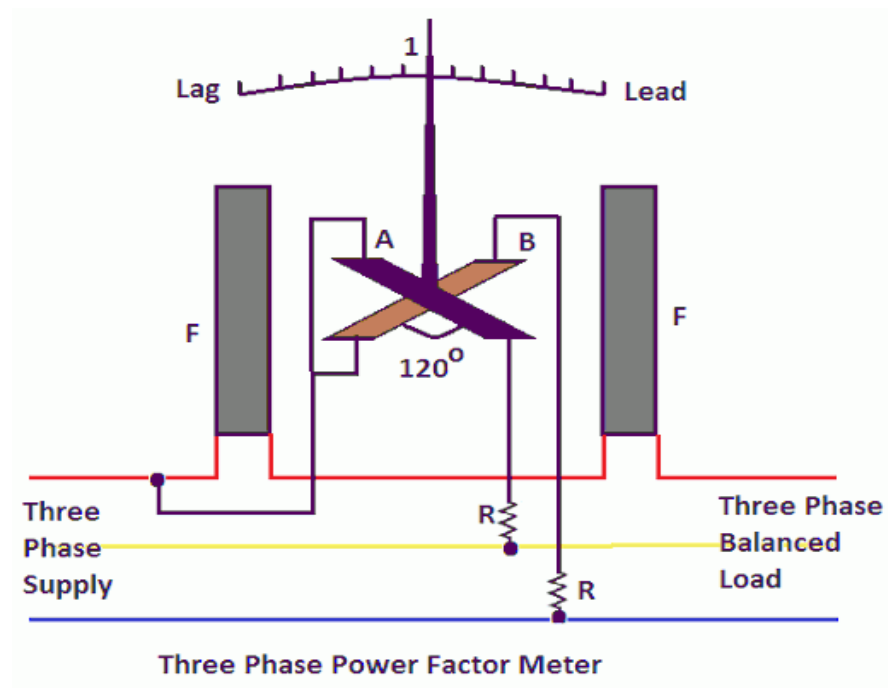

The two identical moving coils A and B are fixed with their planes 120° apart and are connected across the two remaining phases respectively through high resistances as shown in the figure.

In this case, there is no necessity for phase splitting by artificial means, since the required phase displacement between the currents in the moving coils can be obtained from the supply itself.

3 Phase Power Factor Meter Working Principle

When the **three phase power factor meter** is connected in the circuit, under balanced load conditions, the angle through which the pointer is deflected from the unity power factor position is equal to the phase angle of the circuit, because the two moving coils are fixed 120° apart.

The deflections in **three phase power factor meter** are independent of frequency and waveform since the currents in the two moving coils are affected in the same way by any change of frequency.

Power Factor Meter Connection Diagram

Power factor meter connection is shown in Figure.

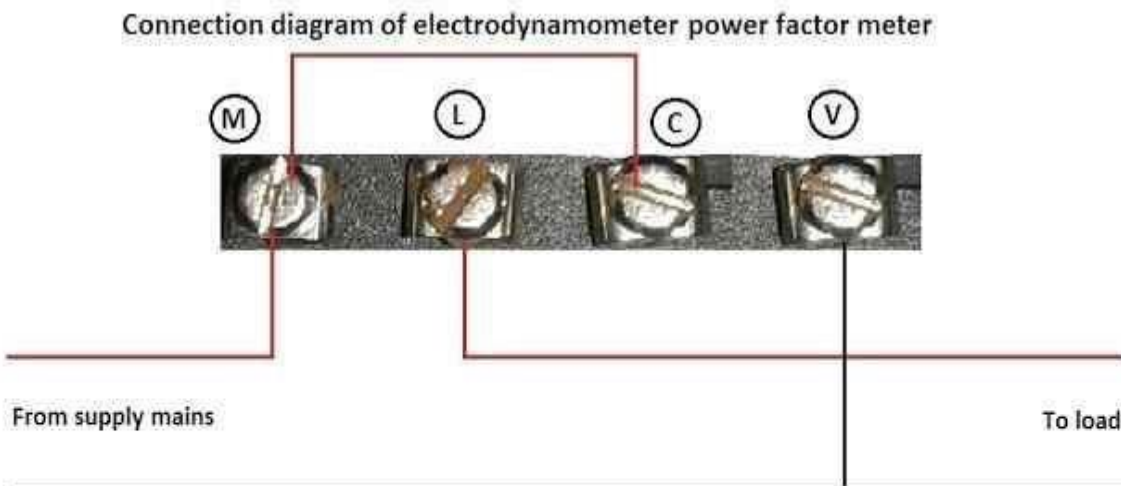

M & L are terminals of current coil .

C & V are terminals of potential coil .

Connections are made as above when supply voltage is equal to rated voltage of meter.

While connecting power factor meter to high voltage M & L terminals are connected to CT and C & V terminals are connected to PT.

Advantages of Electrodynamic Type Power Factor Meters

1. Losses are less because of minimum use of iron parts and also give less error over a small range of frequency as compared to moving iron type instruments.
2. They high torque is to weight ratio.

Disadvantages of Electrodynamic Type Power Factor Meters

1. Working forces are small as compared to moving iron type instruments.
2. The scale is not extended over 360°.
3. Calibration of electrodynamicometer type instruments are highly affected by the changing the supply voltage frequency.

They are quite costly as compared to other instruments

TOPIC - 6

MEASUREMENT OF RESISTANCE, INDUCTANCE & CAPACITANCE

CLASSIFICATION OF RESISTANCE

The classification of resistances, from the point of view of measurement is as follows:

- (1) **Low resistances:** All resistances of the order of 1Ω and under may be classified as low resistances.
- (2) **Medium resistances:** All resistances from 1Ω to about $0.1\text{ M}\Omega$ come under medium resistances.
- (3) **High resistances:** All resistances of the order above $0.1\text{ M}\Omega$ come under high resistances.

Methods for Measurement of low resistances:

The methods for **measurement of low resistances** are:

(i) Ammeter-Voltmeter Method

(ii) Kelvin's double bridge

method (iii) Potentiometer

method

Measurement of Resistance using Potentiometer

The DC [potentiometer](#) method of measurement of resistance is used for measuring the unknown resistance of low value. This can be done by comparing the unknown resistance with the standard resistance. The voltage drop across the known and unknown [resistance](#) is measured and by comparison the value of known resistance is determined.

Let understand this with the help of the circuit diagram. The R is the unknown resistance whose value is needed to be measured. The S is the standard resistance from which the value of unknown resistance is compared. The rheostat is used for controlling the magnitude of current into the circuit.

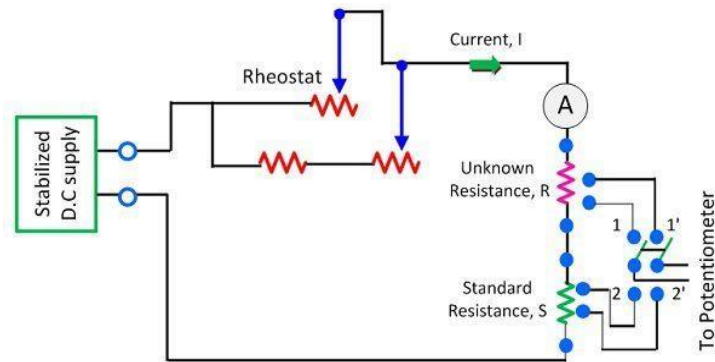

Measurement of Resistance with Potentiometer

Circuit Globe

The double pole double throw switch is used in the circuit. The switch, when moves to position 1, 1' the unknown resistance connects to the circuit, and when it moves to position 2, 2' the standard resistance connects to the circuit.

Consider that when the switch is in position 1, 1' the voltage drop across the unknown resistance is V_r

$$V_R = IR \quad \text{and when it is in 2, 2' the voltage drop across the resistance is } V_s$$

$$V_S = IS$$

On equating the equation (1) and (2), we get

$$\frac{V_R}{V_S} = \frac{IR}{IS}$$

$$\frac{V_R}{V_S} = \frac{R}{S}$$

$$R = \frac{V_R}{V_S} \cdot S$$

- The accuracy of unknown resistance depends on the value of standard resistance.
- The accuracy of the unknown resistance also depends on the magnitude of the current at the time of the readings. If the magnitude of current remains same, the circuit gives the accurate result.
- The [ammeter](#) is used in the circuit for determining the magnitude of current passing through resistor during the reading.

The magnitude of the current is adjusted in such a way that the voltage drop across the resistance is equal to 1 volt.

MEASUREMENT OF MEDIUM RESISTANCES

The different methods for measurement of medium range resistances are

- (i) Ohmmeter method,
- (ii) Voltmeter–ammeter method,
- (iii) Substitution method,
- (iv) Wheatstone-bridge method.

Wheatstone Bridge Method

The Wheatstone bridge is the most commonly used circuit for measurement of medium-range resistances. The Wheatstone bridge consists of four resistance arms, together with a battery (voltage

source) and a galvanometer (null detector). The circuit is shown in Figure

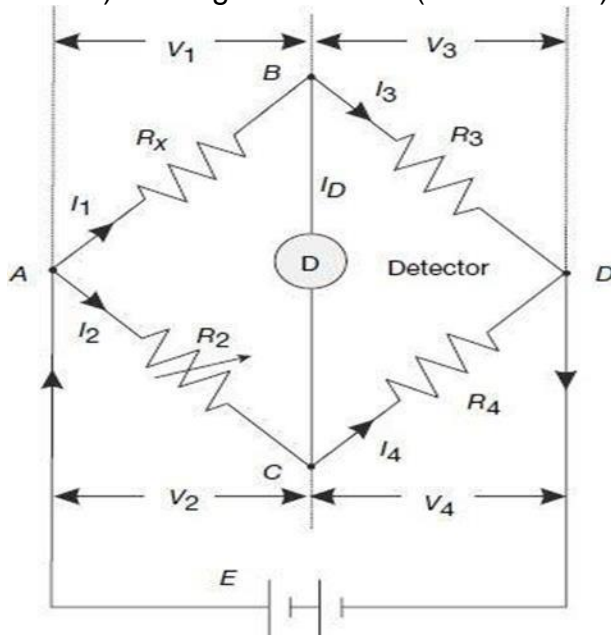

In the bridge circuit, R_3 and R_4 are two fixed known resistances, R_2 is a known variable resistance and R_x is the unknown resistance to be measured. Under operating conditions, current I_D through the galvanometer will depend on the difference in potential between nodes B and C . A bridge balance condition is achieved by varying the resistance R_2 and checking whether the galvanometer pointer is resting at its zero position. At balance, no current flows through the galvanometer. This means that at balance, potentials at nodes B and C are equal. In other words, at balance the following conditions are satisfied:

The detector current is zero, i.e., $I_D = 0$ and thus $I_1 = I_3$ and $I_2 = I_4$

Potentials at node B and C are same, i.e., $V_B = V_C$, or in other words, voltage drop in the arm AB equals the voltage drop across the arm AC , i.e., $V_{AB} = V_{AC}$ and voltage drop in the arm BD equals the voltage drop across the arm CD , i.e., $V_{BD} = V_{CD}$

From the relation $V_{AB} = V_{AC}$ we have $I_1 \times R_x = I_2 \times R_2$

At balanced 'null' position, since the galvanometer carries no current, it as if acts as if open circuited, thus

$$I_1 = I_3 = \frac{E}{R_X + R_3} \text{ and } I_2 = I_4 = \frac{E}{R_2 + R_4}$$

Thus, from Eq. (4.12), we have

$$\frac{E}{R_X + R_3} \times R_X = \frac{E}{R_2 + R_4} \times R_2$$

or,
$$\frac{R_X + R_3}{R_X} = \frac{R_2 + R_4}{R_2}$$

or,
$$\frac{R_X + R_3}{R_X} - 1 = \frac{R_2 + R_4}{R_2} - 1$$

or,
$$\frac{R_X + R_3 - R_X}{R_X} = \frac{R_2 + R_4 - R_2}{R_2}$$

or,
$$\frac{R_3}{R_X} = \frac{R_4}{R_2}$$

or,
$$\frac{R_X}{R_2} = \frac{R_3}{R_4}$$

or,
$$R_X = R_2 \times \frac{R_3}{R_4}$$

Thus, measurement of the unknown resistance is made in terms of three known resistances. The arms BD and CD containing the fixed resistances R_3 and R_4 are called the **ratio arms**. The arm AC containing the known variable resistance R_2 is called the **standard arm**. The range of the resistance value that can be measured by the bridge can be increased simply by increasing the ratio R_3/R_4 .

Measurement of High Resistance (>100kΩ)

Following are few methods used for measurement of high resistance values-

- Loss of Charge Method
- Megger
- Megohm bridge Method
- Direct Deflection Method

Loss of Charge Method

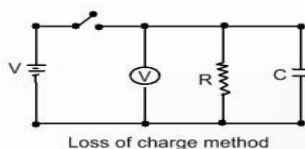

In the loss of charge method unknown resistance is connected in parallel with the capacitor and electrostatic voltmeter. The capacitor is initially charged to some suitable voltage by means of a battery of voltage V and then allowed to discharge through the resistance. The terminal voltage is observed

during discharge and it is given by,
$$v = V e^{-t/CR}$$

OR
$$\frac{V}{v} = e^{t/CR}$$

$$R = \frac{t}{C \text{Log}_e \frac{V}{v}} = \frac{0.4343t}{C \text{Log}_{10} \frac{V}{v}}$$

Or insulation resistance is given by,

The variation of voltage v with time is shown in figure,

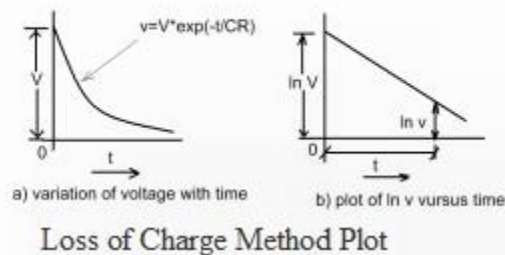

From above equation, it follows that if V , v , C , and t are known the value of R can be computed.

If the resistance R is very large the time for an appreciable fall in voltage is very large and thus this process may become time-consuming. Also the voltage-time curve will thus be very flat and unless great care is taken in measuring voltages at the beginning and at the end of time t , a serious error may be made in the ratio V/v causing the considerable corresponding error in the measured value of R . more accurate results may be obtained by change in the voltage $V-v$ directly and calling this change as

$$R = \frac{0.4343 t}{C \log_{10} \frac{V}{V-e}}$$

e, the expression for R becomes:

This change in voltage may be measured by a galvanometer.

However, from the experimental point of view, it may be advisable to determine the time t from the discharge curve of the capacitor by plotting the curve of $\log v$ against time t . this curve is linear as shown in the second figure and thus the determination of time t from this curve for the voltage to fall from V to v yields more accurate results.

Loss of charge method is applicable to some high resistances, but it requires a capacitor of very high leakage resistance as high as resistance being measured. The method is very attractive if the resistance

being measured is the leakage resistance of a capacitor as in this case auxiliary R and C units are not required.

Actually, in this method, we do not measure the true value of resistance since we assume here that the value of resistance of electrostatic voltmeter and the leakage resistance of the capacitor have infinite value. But in practice corrections must be applied to take into consideration the above two resistances. Let R_1 be the leakage resistance of the capacitor. Also R' be the equivalent resistance of the parallel resistances R and R_1 .

Loss of charge method with leakage resistance of the capacitor

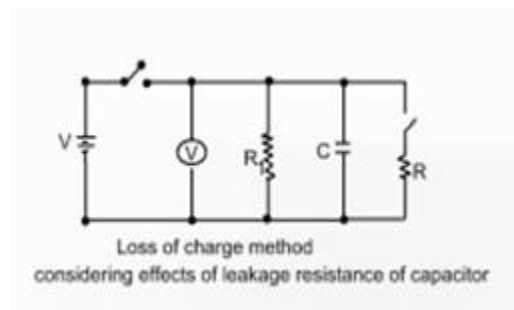

Then discharge equation of capacitor gives,

$$R' = 0.4343 t / (C \log V/v)$$

The test is then repeated with the unknown resistance R disconnected and the capacitor discharging through R_1 . The value of R_1 obtained from this second test and substituted into the expression,

$$R' = (R R_1) / (R + R_1)$$

In order to get the value of R. The leakage resistance of the voltmeter, unless very high should also be taken into consideration.

MEGGER

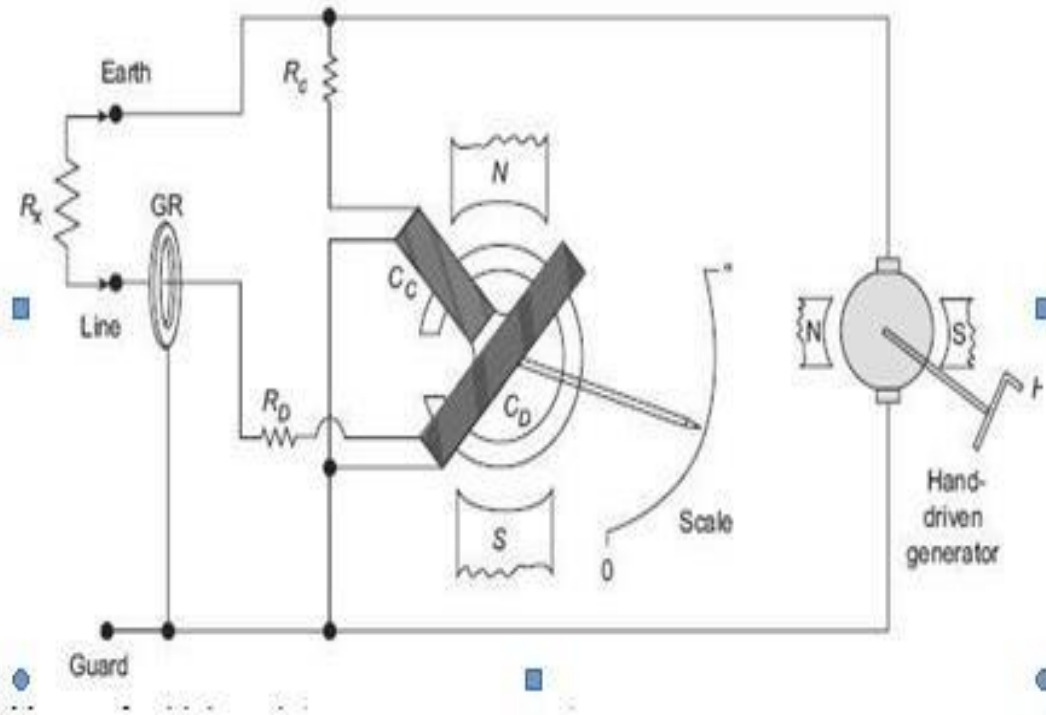

One of the most popular portable type insulation resistance measuring instruments is the mega-ohmmeter or in short, meggar. The meggar is used very commonly for measurement of insulation resistance of electrical machines, insulators, bushings, etc.

The traditional analog deflecting-type meggar is essentially a permanent magnet crossed-coil shunt type ohmmeter.

The instrument has a small permanent magnet dc generator developing 500 V dc (some other models also have 100 V, 250 V, 1000 or 2500 V generators). The generator is hand driven, through gear arrangements, and through a centrifugally controlled clutch switch which slips at a predefined speed so that a constant voltage can be developed. Some meggars also have rectified ac as power supply.

The moving system in such instruments consists of two coils, the control coil C_C and the deflecting coil C_D . Both the coils are mounted rigidly on a shaft that carries the pointer as well. The two coils move in the air gap of a permanent magnet. The two coils are arranged with such numbers of turns, radii of action, and connected across the generator with such polarities that, for external magnetic fields of uniform intensity, the torque produced by the individual coils are in opposition thus giving an astatic combination. The deflecting coil is connected in series with the unknown resistance R_X under measurement, a fixed resistor R_D and then the generator. The control coil or the compensating coil, along with the fixed resistance R_C is connected directly across the generator. For any value of the unknown, the coils and the pointer take up a final steady position such that the torques of the two coils are equal and balanced against each other. For example, when the

resistances R_X under measurement is removed, i.e., the test terminals are open-circuited, no current flows through the deflecting coil C_D , but maximum current will flow through the control coil C_C . The control coil C_C thus sets itself perpendicular to the magnetic axis with the pointer indicating ' $\infty \Omega$ ' as marked in the scale. As the value of R_X is brought down from open circuit condition, more and more current flows through the deflecting coil CD , and the pointer moves away from the ' $\infty \Omega$ ' mark clockwise on the scale, and ultimately reaches the ' 0Ω ' mark when the two test terminals are short circuited.

The surface leakage problem is taken care of by the guard-wire arrangement. The guard ring and the guard wire diverts the surface leakage current from reaching the main moving system and interfering with its performance.

EXPECTED QUESTIONS FROM THE LECTURE :

- i) What is Meggar?
- ii) Explain the working principle of Meggar.
- iii) Describe the construction of Meggar with proper diagram.
- iv) Write applications of Meggar.

DIGITAL MULTIMETER

A digital multi-meter is an electronic instrument which can measure very precisely the dc and ac voltage, current (dc and ac), and resistance. All quantities other than dc voltage is first converted into an equivalent dc voltage by some device and then measured with the help of digital voltmeter.

The procedures of measurement of different quantities are described below:

For measurement of ac voltage, the input voltage, is fed through a calibrated, compensated attenuator, to a precision full-wave rectifier circuit followed by a ripple reduction filter. The resulting dc is fed to an Analog Digital Converter (ADC) and the subsequent display system. Many manufacturers provide the same attenuator for both ac and dc measurements.

For current measurement, the drop across an internal calibrated shunt is measured directly by the ADC in the 'dc current mode', and after ac to dc conversion in the 'ac current mode'. This drop is often in the range of 200 mV (corresponding to full scale).

Due to the lack of precision in the ac–dc conversions, the accuracy in the ac range is generally of the order of 0.2 to 0.5%. In addition, the measurement range is often limited to about 50 Hz at the lower

frequency end due to the ripple in the rectified signal becoming a non-negligible percentage of the display and hence results in fluctuation of the displayed number. At the higher frequency end, deterioration of the performance of the ADC converter limits the accuracy. In ac measurement the reading is often average or rms values of the unknown current. Sometimes for measurement of current, a current-to-voltage converter may also be used.

The current under measurement is applied to the summing junction at the input of the op-amp. The current in the feedback resistor I_R is equal to the input current I_{IN} because of very high input impedance of the op-amp. The current I_R causes a voltage drop across one of the resistors, which is proportional to the input current I_{IN} . Different resistors are employed for different ranges.

For resistance measurement the digital multi-meter operates by measuring the voltage across the externally connected resistance, resulting from a current forced through it from a calibrated internal current source. The accuracy of the resistance measurement is of the order of 0.1 to 0.5% depending on the accuracy and stability of the internal current sources. The accuracy may be proper in the highest range which is often about 10 to 20 M Ω . In the lowest range, the full scale may be nearly equal to >200 Ω with a resolution of about 0.01 Ω for a 4½ digit digital multi-meter. In this range of resistance measurement, the effect of the load resistance will have to be carefully considered.

<i>Analog Multimeter</i>	<i>Digital Multimeter</i>
No external power supply required.	An external power supply is required.
Visual indication of change in reading is better observable.	Less observable.
Less effect of electronic noise.	More affected by electronic noise.
Less isolation problems.	More isolation problems.
It has less accuracy.	Highly accurate instrument.
Interface of the output with external equipment is not possible.	Possible to connect an external instrument with the output reading.
Simple in construction.	Very complicated in construction.
Big in size.	Small in size.

Measurement of inductance by Maxwell's Bridge method :

Types of Maxwell's Bridge

Two methods are used for determining the self-inductance of the circuit. They are

1. Maxwell's Inductance Bridge
2. Maxwell's inductance Capacitance Bridg

Maxwell's Inductance Bridge :

In such type of bridges, the value of unknown [resistance](#) is determined by comparing it with the known value of the standard self-inductance. The connection diagram for the balance Maxwell bridge is shown in the figure below.

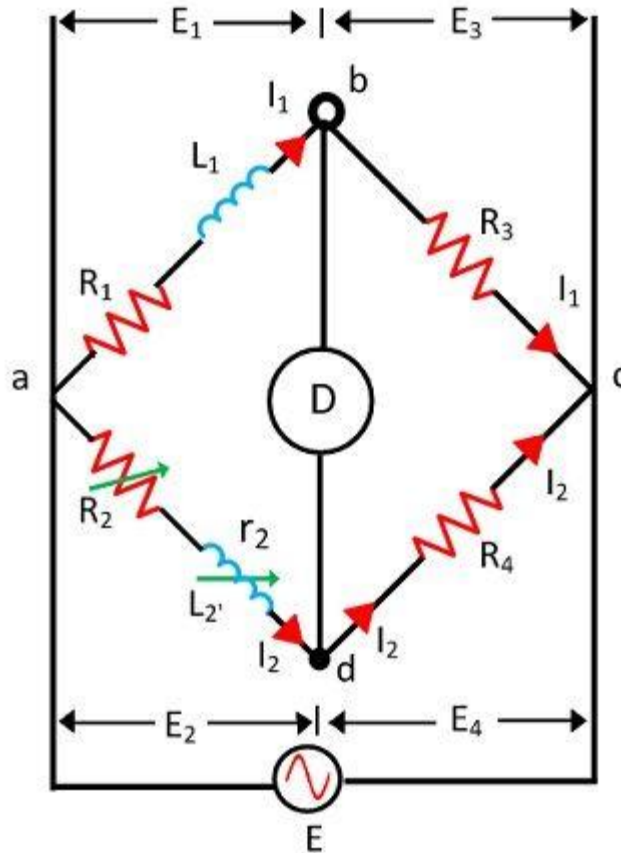

Maxwell's Inductance Bridge

Circuit Globe

Let, L_1 – unknown inductance of resistance R_1 .

L_2 – Variable inductance of fixed resistance r_1 .

R_2 – variable resistance connected in series with inductor L_2 .

R_3, R_4 – known non-inductance resistance

$$L_1 = \frac{R_3}{R_4} L_2$$

At balance,

$$R_1 = \frac{R_3}{R_4} (R_2 + r_2)$$

bridge, the additional resistance is also inserted into the circuit. The value of the R_3 and the R_4 resistance varies from 10 to 1000 ohms with the help of the resistance box. Sometimes for balancing the.

Measurement of capacitance by Schering Bridge method :

Schering Bridge :

This bridge is used to measure to the capacitance of the capacitor, dissipation factor and measurement of relative permittivity. Let us consider the circuit of **Schering bridge** as shown below:

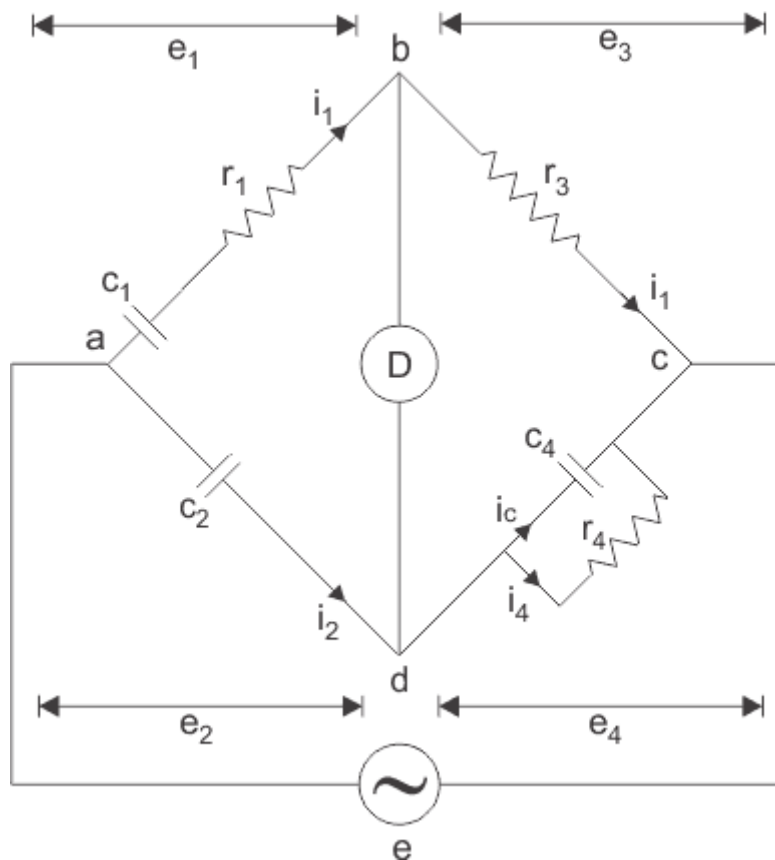

Schering Bridge

Here, c_1 is the unknown capacitance whose value is to be determined with series electrical resistance r_1 . c_2 is a standard capacitor.

c_4 is a variable capacitor.

r_3 is a pure resistor (i.e. non inductive in nature).

And r_4 is a variable non inductive resistor connected in parallel with variable capacitor c_4 . Now the supply is given to the bridge between the points a and c. The detector is connected between b and d.

From the theory of ac bridges we have at balance condition,

Substituting the values of z_1 , z_2 , z_3 and z_4 in the above equation, we get

$$\left(r_1 + \frac{1}{j\omega c_1}\right) \left(\frac{r_4}{1 + j\omega c_4 r_4}\right) = \frac{r_3}{j\omega c_2}$$

$$\left(r_1 + \frac{1}{j\omega c_1}\right) r_4 = \frac{r_3}{j\omega c_2} (1 + j\omega c_4 r_4)$$

$$r_1 r_4 - \frac{j r_4}{\omega c_1} = -\frac{j r_3}{\omega c_2} + \frac{r_3 r_4 c_4}{c_2}$$

Equating the real and imaginary parts and the separating we get,

$$r_1 = \frac{r_3 c_4}{c_2}$$

$$c_1 = c_2 \frac{r_4}{r_3}$$

EXPECTED QUESTIONS FROM THE LECTURE :

1. Briefly describe the performance characteristics of digital measurement.
2. Write down the comparison between analog and digital multi-meters.
3. With the help of a functional block diagram, describe the principle of operation of a digital multi-meter.
4. What are the applications of Digital Multi-meter.

TOPIC-7

SENSORS AND TRANSDUCERS

A **sensor** is a device that measures a physical quantity and converts it into a signal which can be read by an observer or by an instrument.

For example, a mercury thermometer converts the measured temperature into expansion and contraction of a liquid which can be read on a calibrated glass tube. A thermocouple converts temperature to an output voltage which can be read by a voltmeter. For accuracy, all sensors need to be calibrated against known standards.

In everyday life, sensors are used everywhere such as touch sensitive mobile phones, laptop's touch pad, touch controller light, etc. People use so many applications of sensors in their everyday lifestyle that even they are not aware about it. Examples of such applications are in the field of medicine, machines, cars, aerospace, robotics and manufacturing plants. The sensitivity of the sensors is the change of sensor's output when the measured quantity changes. For example, the output increases 1 volt when the temperature in the thermocouple junction increases 1°C. The sensitivity of the thermocouple element is 1 volt/°C. To measure very small changes, the sensors should have very high sensitivity.

A **transducer** is a device, usually electrical, electronic, electro-mechanical, electromagnetic, photonic, or photovoltaic that converts one type of energy or physical attribute to another (generally electrical or mechanical) for various measurement purposes including measurement or information transfer (for example, pressure sensors).

The term transducer is commonly used in two senses; the sensor, used to detect a parameter in one form and report it in another (usually an electrical or digital signal), and the audio loudspeaker, which converts electrical voltage variations representing music or speech to mechanical cone vibration and hence vibrates air molecules creating sound.

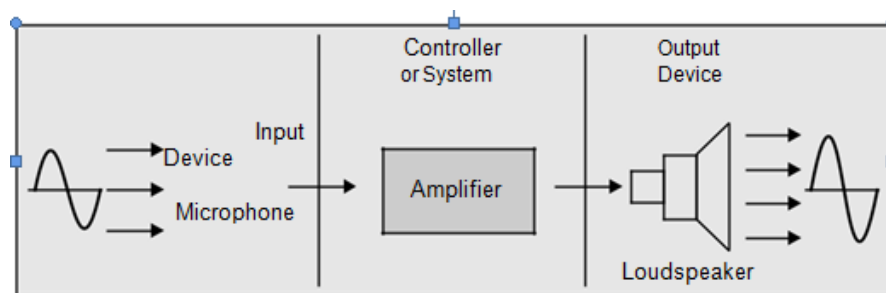

Basic Requirements of a Transducer

The main objective of a transducer is to react only for the measurement under specified limits for which it is designed. It is, therefore, necessary to know the relationship between the input and output quantities and it should be fixed. A transducer should have the following basic requirements:

1. Linearity

Its input vs output characteristics should be linear and it should produce these characteristics in balanced way.

2. Ruggedness

A transducer should be capable of withstanding overload and some safety arrangements must be provided with it for overload protection.

3. Repeatability

The device should reproduce the same output signal when the same input signal is applied again and again under unchanged environmental conditions, e.g., temperature, pressure, humidity, etc.

4. High Reliability and Stability

The transducer should give minimum error in measurement for temperature variations, vibrations and other various changes in surroundings.

5. High Output Signal Quality

The quality of output signal should be good, i.e., the ratio of the signal to the noise should be high and the amplitude of the output signal should be enough.

6. No Hysteresis

It should not give any hysteresis during measurement while input signal is varied from its low value to high value and vice versa.

7. Residual Reformation

There should not be any deformation on removal of input signal after long period of use.

Selection of Transducer

Following are the factors which need to be considered while selecting a transducer:

- High input impedance and low output impedance, to avoid loading effect.
- Good resolution over its entire selected range.
- Highly sensitive to desired signal and insensitive to unwanted signal.
- Preferably small in size.
- High degree of accuracy and repeatability.

- Selected transducer must be free from errors

EXPECTED POSSIBLE QUESTIONS

1. Define Sensor and explain it with some examples.
2. What is Transducer? Explain briefly with some examples.
3. What are the basic requirements of transducer? Explain each term briefly.
4. What are the factors need to be considered to select a transducer?

CLASSIFICATION OF TRANSDUCERS

The classification of transducers may be explained as follows:

Based on the physical phenomenon:

1. Primary Transducer
2. Secondary Transducer

On the basis of application transducer may be classified as primary and secondary transducer. When the input signal is directly sense by the transducer, the non-electrical energy is converted into electrical energy directly then, this type of transducer is known as **primary transducer**. For example thermistor, senses the temperature directly and causes the change in resistance with the change in temperature.

When the input signal is first sensed by some sensor or detector, then its output signal is feed to the other instrument as an input. The output of this instrument is given as the input of transducer for converting into electrical energy. This type of transducer is in **secondary transducer** classification. For example in the case of pressure measurement, we use bourdon tube to convert pressure into displacement, then the pressure is converter into output voltage with the help of LVDT. Here the secondary transducer is LVDT. We will discuss the bourdon tube and LVDT in this chapter.

Based on the power type

1. Active transducer
2. Passive transducer

Active transducer does not require any auxiliary power source to produce their output. It is also called self generating type transducer.

Active and Passive Transducers

Active transducer is also known as self generating type transducer. It develops their own voltage or current from the physical phenomenon being measured. Active transducers generate electric current or voltage directly in response to environmental stimulation. Examples of active transducers are thermocouples and piezoelectric accelerometers. Thermocouples produce a voltage related to a temperature of two metals and if the two junctions are at different temperatures, electricity is generated.

Passive transducers are also known as externally powered transducers. It derives the power required for energy conversion from an external power source. Passive transducers produce a change in some passive electrical quantity, such as capacitance, resistance, or inductance, as result of stimulation. These usually require additional electrical energy for excitation. A simple example of a passive transducer is a device containing a length of wire and a moving contact touching the wire. The position of the contact determines the effective length of the wire, varying the resistance of the length of wire. Other examples of passive transducers are strain gauges, resistance temperature detectors (RTDs), and thermistors.

Based on the type of output

1. Analog transducer
2. Digital transducer

Based on the electrical phenomenon

1. Resistive transducer
2. Capacitive transducer
3. Inductive transducer
4. Photoelectric transducer
5. Photovoltaic transducer

Based on the non-electrical phenomenon

1. Linear displacement
2. Rotary displacement

Based on the transduction phenomenon,

1. Transducer
2. Inverse transducer.

Characteristics of Transducer

Known values of the measured (input) are applied to a sensor (measurement system) for the purpose of observing the sensor (system) output. The main characteristics of transducer are given below:

Sensitivity It can be defined as the ratio of the *incremental output* and the *incremental input*. While defining the sensitivity, we assume that the input-output characteristic of the instrument is approximately linear in that range.

Range The range of the sensor is the maximum and minimum values of applied parameter that can be measured.

Precision The concept of precision refers to the degree of *reproducibility* of a measurement. In other words, if exactly the same value were measured a number of times, an ideal sensor would output exactly the same value every time. But real sensors output a range of values distributed in some manner relative to the actual correct value.

Resolution The smallest difference between measured values that can be discriminated. For example, it corresponds to the last stable figure on a digital display. This specification is the smallest detectable incremental change of input parameter that can be detected in the output signal. Resolution can be expressed either as a proportion of the reading (or the full-scale reading) or in absolute terms.

Accuracy The accuracy of the sensor is the maximum difference that will exist between the actual value and the indicated value at the output of the sensor. Again, the accuracy can be expressed either as a percentage of full scale or in absolute terms.

Linearity The linearity of the transducer is an expression of the extent to which the actual measured curve of a sensor departs from the ideal curve. Fig. 14.2 shows a somewhat exaggerated relationship between the ideal, or least squares fit, line and the actual measured or *calibration* line. Linearity is often specified in terms of *percentage of non-linearity*, which is defined as,

$$\text{Non-linearity (\%)} = \frac{\text{Maximum input deviation}}{100 \text{ Maximum full scale input}} \times$$

Hysteresis Hysteresis exists not only in magnetic circuits, but in instruments also. For example, the deflection of a diaphragm type pressure gage may be different for the same pressure, but one for increasing and other for decreasing, A transducer should be capable of following the changes of the input parameter regardless of which direction the change is made, hysteresis is the measure of this property.

EXPECTED POSSIBLE QUESTIONS

1. Classify the transducers on the basis of power type and explain them.
2. Classify the transducers on the basis of electrical phenomenon.
3. Explain Primary and secondary transducers with suitable examples.
4. Write down the characteristics of transducers and explain each term briefly.
- 5.

RESISTIVE TRANSDUCER

The **transducer** whose **resistance varies** because of the **environmental effects** such type of transducer is known as the resistive transducer. The **change in resistance is measured** by the **ac or dc measuring devices**. The **resistive transducer** is used for measuring the **physical quantities like temperature, displacement, vibration etc.**

The measurement of the physical quantity is quite difficult. The resistive [transducer](#) converts the physical quantities into variable [resistance](#) which is easily measured by the meters. The process of variation in resistance is widely used in the industrial applications.

The resistive transducer can work both as the primary as well as the secondary transducer. The primary transducer changes the physical quantities into a mechanical signal, and secondary transducer directly transforms it into an electrical signal.

Example – The circuit of the sliding resistive transducer is shown in the figure below. The sliding contacts are placed on the resistive element. The slider moves horizontally. The movement of the slider changes the value of the resistive element of the transducer which is measured by the voltage source E. The displacement of the slider is converted into an electrical signal.

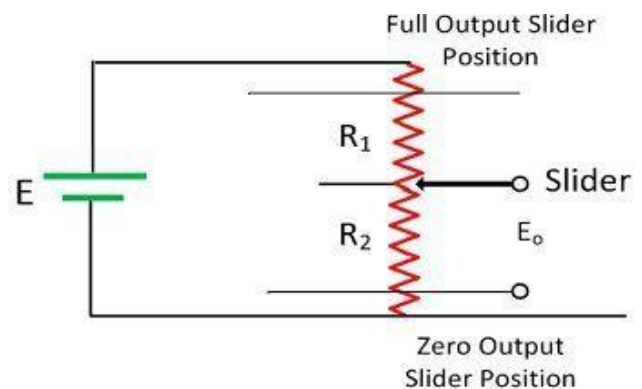

Working Principle of Resistive Transducer

The resistive transducer element works on the principle that the resistance of the element is directly proportional to the length of the

conductor and inversely proportional to the area of the conductor.

$$R = \rho L / A$$

Where, R – resistance in ohms.

A – cross-section area of the conductor in meter square. L – Length of the conductor in meter square.

ρ – the resistivity of the conductor in materials in ohm meter.

The resistive transducer is designed by considering the variation of the length, area and resistivity of the metal.

Applications of Resistive Transducer

The following are the applications of the resistive transducer.

1. **Potentiometer** – The translation and rotatory [potentiometer](#) are the examples of the resistive transducers. The resistance of their conductor varies with the variation in their lengths which is used for the measurement of displacement.

2. **Strain gauges** – The resistance of their [semiconductor](#) material changes when the strain occurs on it. This property of metals is used for the measurement of the pressure, force-displacement etc.
3. **Resistance Thermometer** – The resistance of the metals changes because of changes in temperature. This property of conductor is used for measuring the temperature.
4. **Thermistor** – It works on the principle that the temperature coefficient of the thermistor material varies with the temperature. The [thermistor](#) has the negative temperature coefficient. The Negative temperature coefficient means the temperature is inversely proportional to resistance.

Advantages of Resistive Transducer

The following are the advantages of the resistive transducer.

1. Both the AC and DC, current or voltage is appropriate for the measurement of variable resistance.
2. The resistive transducer gives the fast response.
3. It is available in various sizes and having a high range of resistance.

POTENTIOMETER

The potentiometers or the “pots”, as it is commonly known in the electric circles, is a three terminal variable resistor. Out of its three terminals, two of them are fixed and one is a varying (linear / rotary) terminal.

The value of the resistance can be changed from zero to a defined upper limit, by just manually sliding the contact over a resistive strip. As the resistance changes, the current through the circuit changes and hence according to the ohms law, the voltage across the resistive material also changes. A potentiometer has three terminals. When connected to a circuit, the two fixed terminals are connected to the ends of the resistive elements while the third terminal is connected to the wiper.



Potentiometer Symbol

In the circuit diagram shown below, the terminals of the potentiometer are marked 1, 2 and 3. The voltage supply is connected across terminals 1 and 3, positive lead to terminal one while negative lead to terminal three. The terminal 2 is connected to the wiper.

Lets name the two resistors, R_1 and R_2 (Refer figure). The wiper voltage is actually the voltage across R_2 . The circuit now looks like a voltage divider, where the output voltage is given the equation:

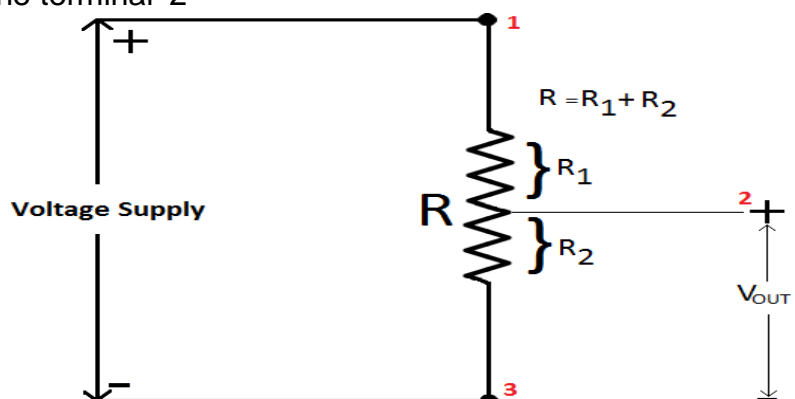

$$V_{\text{out}} = \left\{ \frac{R_2}{R_1 + R_2} \right\} \times V; \quad \text{where } V = \text{supply voltage.}$$

LINEAR POTENTIOMETER

A linear potentiometer transducer consists of a potentiometer, which is short circuited by a slider. The other end of the slider is connected to a slider arm. The force summing device on the slider arm causes linear displacement of the slider causing the short circuit of a certain portion of the resistance in the potentiometer. Let the whole resistance positions on the potentiometer be ABC. Let the resistance position caused by the slider movement be BC. As the movement of the slider moves further to the right, the amount of resistance increases. This increase in resistance value can be noted according to the corresponding change in the linear displacement of the slider. The change in resistance can be calculated with the help of a Wheatstone bridge.

Another easy method than calculating the resistance with the help of a bridge connection is to connect a constant current source in series with the potentiometer. Thus a voltage will be developed. This voltage can be measured and hence the resistance, $R = V/I$.

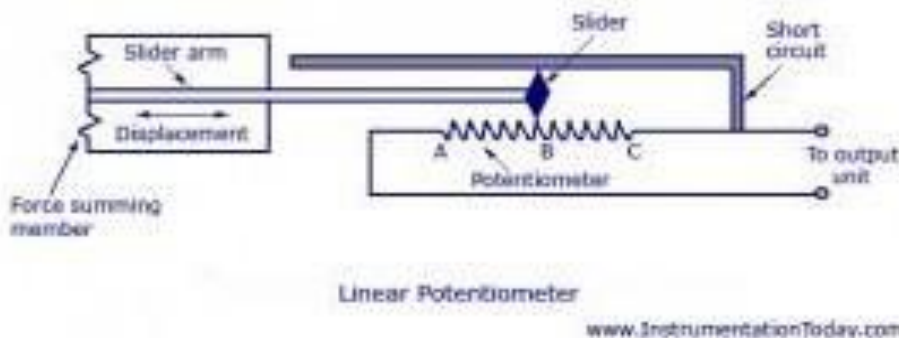

ROTARY POTENTIOMETER

The rotary type potentiometers are used mainly for obtaining adjustable supply voltage to a part of electronic circuits and electrical circuits. The volume controller of a radio transistor is a popular example of a rotary potentiometer where the rotary knob of the potentiometer controls the supply to the amplifier.

This type of potentiometer has two terminal contacts between which a uniform resistance is placed in a semi-circular pattern. The device also has a middle terminal which is connected to the resistance through a sliding contact attached with a rotary knob. By rotating the knob one can move the sliding contact on the semi-circular resistance. The voltage is taken between a resistance end contact and the sliding contact. The potentiometer is also named as the POT in short. POT is

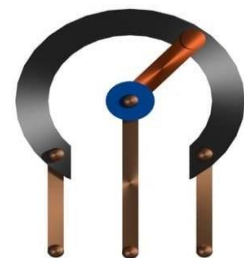

also used in substation battery chargers to adjust the charging voltage of a battery. There are many more uses of rotary type potentiometer where smooth voltage control is required.

EXPECTED POSSIBLE QUESTIONS

1. Define Resistive transducer with some examples.
2. Explain the working principle of Resistive transducer briefly.
3. What are the various advantages of resistive transducer?
4. Write down few applications of resistive transducer.
5. Draw the circuit diagram of potentiometer and explain its working principle with its types.

THERMISTOR

The **thermistor** is a kind of **resistor** whose **resistivity** depends on surrounding **temperature**. It is a **temperature sensitive device**. The word thermistor is derived from the word, **thermally sensitive resistor**. The thermistor is made of the **semiconductor material** that means their **resistance** lies between the **conductor and the insulator**. The **variation** in the thermistor **resistance** shows that either **conduction or power dissipation** occurs in the thermistor. The circuit diagram of thermistor uses the rectangular block which has a diagonal line on it.

Construction of Thermistor

The thermistor is made with the sintered mixture of metallic oxides like manganese, cobalt, nickel, cobalt, copper, iron, uranium, etc. It is available in the form of the bead, rod and disc. The different types of the thermistor are shown

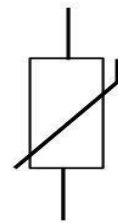

in the figure below.

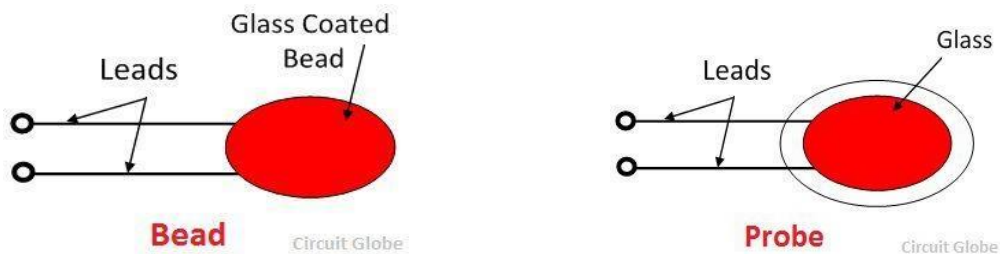

The bead form of the thermistor is smallest in shape, and it is enclosed inside the solid glass rod to form probes.

The disc shape is made by pressing material under high pressure with diameter range from 2.5 mm to 25mm.

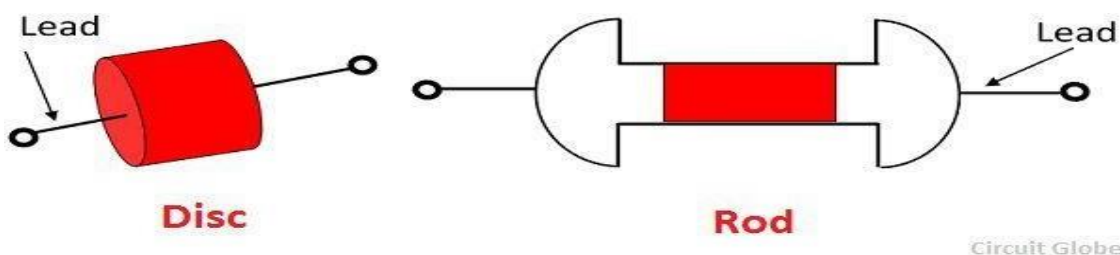

Resistance Temperature Characteristic of Thermistor

The relation between the absolute temperature and the resistance of the thermistor is mathematically expressed by the equation shown below.

$$R_{T_1} = R_{T_2} \exp \left[\beta \left(\frac{1}{T_1} - \frac{1}{T_2} \right) \right]$$

Where, R_{T_1} – Resistance of the thermistor at absolute temperature T_1 in Kelvin. R_{T_2} – Resistance of the thermistor at absolute temperature T_2 in Kelvin. β – a temperature depending on the material of thermistor.

The resistance temperature coefficient of the thermistor is shown in the figure below. The graph below shows that the thermistor has a negative temperature coefficient, i.e., the temperature is inversely proportional to the resistance. The resistance of the thermistor changes from 10^5 to 10^{-2} at the temperature between -100°C to 400°C .

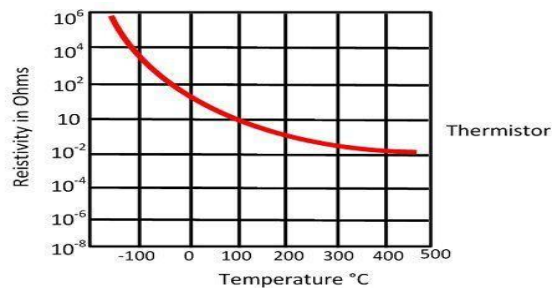

Resistance Temperature Characteristic
Circuit Globe

Types of Thermistor

The thermistor is classified into types. They are the negative temperature coefficient and the positive temperature coefficient thermistor.

1. Negative Temperature Coefficient Thermistor – In this type of thermistor the temperature increases with the decrease of the resistance. The resistance of the negative temperature coefficient thermistor is very large due to which it detects the small variation in temperature.
2. Positive Temperature Coefficient Thermistor – The resistance of the thermistor increases with the increases in temperature.

Advantages of Thermistor

The following are the advantages of the thermistor.

1. The thermistor is compact, long durable and less expensive.
2. The properly aged thermistor has good stability.
3. The response time of the thermistor changes from seconds to minutes. Their response time depends on the detecting mass and the thermal capacity of the thermistor.

4. The upper thermistor limit of the temperature depends on the physical variation of the material, and the lower temperature depends on the resistance reaching a large value.
5. The self-heating of the thermistor is avoided by minimising the current passes through it.
6. The thermistor is installed at the distance of the measuring circuit. Thus the reading is free from the error caused by the resistance of the lead.

RESISTANCE THERMOMETER

The **resistance thermometer** or **resistance temperature detector (RTD)** uses the **resistance of electrical conductor** for measuring the **temperature**. The resistance of the **conductor varies** with the **time**. This property of the conductor is used for **measuring the temperature**. The main function of the RTD is to give a **positive change in resistance with temperature**.

The metal has a high-temperature coefficient that means their temperature increases with the increase in temperature. The carbon and germanium have low-temperature coefficient which shows that their [resistance](#) is inversely proportional to temperature.

Material used in Resistive Thermometer

The resistance thermometer uses a sensitive element made of extremely pure metals like platinum, copper or nickel. The resistance of the metal is directly proportional to the temperature. Mostly, platinum is used in resistance thermometer. The platinum has high stability, and it can withstand high temperature.

Gold and silver are not used for RTD because they have low resistivity. Tungsten has high resistivity, but it is extremely brittle. The copper is used for making the RTD element. The copper has low resistivity and also it is less expensive. The only disadvantage of the copper is that it has low linearity. The maximum temperature of the copper is about 120°C.

The RTD material is made of platinum, nickel or alloys of nickel. The nickel wires are used for a limited temperature range, but they are quite nonlinear.

The following are the requirements of the conductor used in the RTDs.

1. The resistivity of the material is high so that the minimum volume of conductor is used for construction.
2. The change in resistance of the material concerning temperature should be as high as possible.
3. The resistance of the material depends on the temperature.

The resistance versus temperature curve is shown in the figure below. The curves are nearly linear, and for small temperature range, it is very evident.

Construction of Resistive Thermometer

The resistance thermometer is placed inside the protective tube for providing the protection against damage. The resistive element is formed by placing the platinum wire on the ceramic bobbin. This resistance element is placed inside the tube which is made up of stainless steel or copper steel.

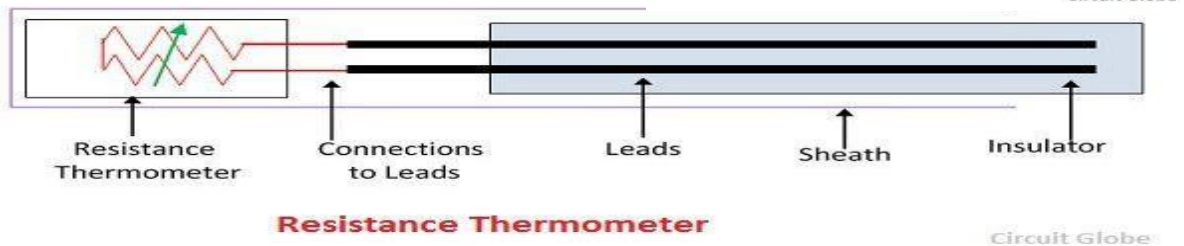
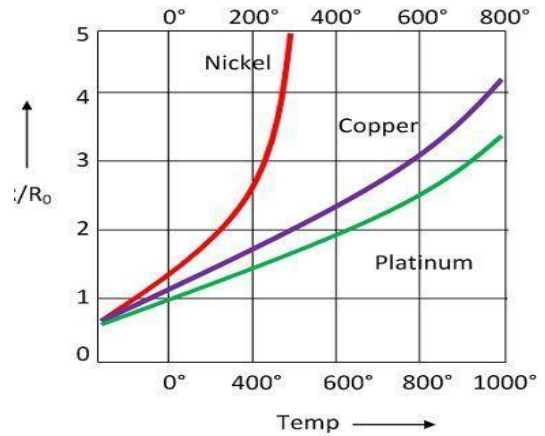

The lead wire is used for connecting the resistance element with the external lead. The lead wire is covered by the insulated tube which protects it from short circuit. The ceramic material is used as an insulator for high-temperature material and for low-temperature fibre or glass is used.

Operation of Resistance Thermometer

The tip of the resistance thermometer is placed near the measurand heat source. The heat is uniformly distributed across the resistive element. The changes in the resistance vary the temperature of the element. The final resistance is measured. The below mention equations measure the variation in temperature.

$$R_0(1 + \alpha_1 T + \alpha_2 T^2 + \dots + \alpha_n T^n + \dots) \dots \dots \text{equ}(1)$$

Where, R_0 – resistance at temperature $T = 0$ and $\alpha_1, \alpha_2, \alpha_3, \dots, \alpha_n$ are constants.

Linear Approximation

The linear approximation is the way of estimating the resistance versus temperature curve in the form of the linear equation.

$$R_\theta = R_{\theta_0}(1 + \alpha_{\theta_0} \Delta\theta)$$

where R_θ – approximation resistance at $\theta^\circ\text{C}$
 R_{θ_0} – approximation resistance at $\theta_0^\circ\text{C}$

$\Delta\theta = \theta - \theta_0$ change in temperature $^\circ\text{C}$ and the α_{θ_0} – resistance temperature coefficient at $\theta_0^\circ\text{C}$

Quadratic Approximation

The quadratic approximation gives the accurate approximation of the resistance temperature curve.

The approximation is expressed in the form of the quadratic equation.

$$R_{\theta} = R_{\theta_0} [1 + \alpha_1 \Delta\theta + \alpha_2 (\Delta\theta)^2]$$

α_1 – linear fractional change in resistance

α_2 – quadratic function change in resistance.

The resistance thermometer is very less sensitive, and the metal used for making the resistive element is less expensive.

Difference between RTD & Thermistor

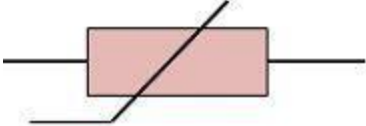
Basis For Comparison	RTD (Resistance Temperature Detector)	Thermistor
Definition	The device use for measuring the change in temperature is known as the RTD or Resistance Temperature Detector.	It is a thermal resistor whose resistance changes with the temperature.
Symbol		
Material	Metals (platinum, nickel, copper, etc.)	Semiconductor
Accuracy	Less accurate.	Their accuracy is high. It can detect even small changes in temperature because of negative temperature coefficient.
Response Time	Slow	Fast
Temperature Range	-230°C to 660°C	-60°C to 15°C
Characteristic Graph	Linear	Non-linear

Sensitivity	Low	High
Size	Large	Small
Cost	Cheap	Expensive
Resistivity	High	Low
Hysteresis Effect	Low	High
Applications	In industries for measuring large temperature.	For measuring the temperature of home appliances.

EXPECTED POSSIBLE QUESTIONS

1. Define thermistor and resistive temperature detector briefly with some examples.
2. Explain construction of thermistor with its characteristics.
3. Write down the types and advantages of thermistors.
4. Explain construction of RTD with its operation characteristics.
5. Differentiate between thermistor and RTD.

STRAIN GAUGES

The strain gauge is an electrical transducer; it is used to measure mechanical surface tension. Strain gauge can detect and convert force or small mechanical displacement into electrical signals. On the application of force a metal conductor is stretched or compressed, its resistance changes owing to the fact both length and diameter of conductor change. Also, there is a change on the value of resistivity of the conductor when it is strained and this property of the metal is called piezo-resistive effect. Therefore, resistance strain gauges are also known as piezo-resistive gauges. The strain gauges are used for measurement of strain and associated stress in experimental stress analysis. Secondly, many other detectors and transducers, for example the load cell, torque meter, flow meter, and accelerometer employ strain gauge as a secondary transducer.

Theory of Resistance Strain Gauges

The change in the value of resistance by the application of force can be explained by the normal dimensional changes of elastic material. If a positive strain occurs, its longitudinal dimension (x -direction) will increase while there will be a reduction in the lateral dimension (y -direction). The reverse happens for a negative strain. Since the resistance of a conductor is directly proportional to its length and inversely proportional to its cross-sectional area, the resistance changes. The resistivity of a conductor is also changed when strained. This property is known as piezo-resistive effect.

Let us consider a strain gauge made of circular wire. The wire has the dimensions:

length L , area A , diameter D before being strained. The material of the wire has a resistivity ρ .

$$\therefore \text{resistance of unstrained gauge } R = \rho \frac{L}{A}$$

Poisson's ratio

$$v = \frac{\text{Lateral strain}}{\text{Longitudinal strain}} = - \frac{\partial D / D}{\partial L / L}$$

The gauge factor is defined as the ratio of per unit change in resistance to per unit change in length. Where, $\epsilon = \frac{\Delta L}{L} = \text{Strain}$

$$\text{gauge factor } G_f = \frac{\Delta R / R}{\Delta L / L} = 1 + 2v + \frac{\Delta \rho / \rho}{\epsilon}$$

Inductive Transducers

The inductive transducers work on the principle of the magnetic induction of magnetic material. The induction of the magnetic material depends on a number of variables like the number of turns of the coil on the material, the size of the magnetic material, and the permeability of the flux path. In the inductive transducers the magnetic materials are used in the flux path and there are one or more air gaps. The change in the air gap also results in change in the inductance of the circuit and in most of the inductive transducers it is used for the working of the instrument. There are two types of inductive transducers, they are given below:

- Linear Variable Differential Transformer
- Rotary Variable Differential Transformer

LINEAR VARIABLE DIFFERENTIAL TRANSFORMER (LVDT)

The most widely used inductive transducer to translate the linear motion into electrical signals is the Linear Variable Differential Transformer (LVDT). The transformer consists of a single primary winding 'P' and two secondary windings S_1 and S_2 wound on a cylindrical former. A sinusoidal voltage of amplitude 3 to 15 Volts and frequency 50 to 20000 Hz is used to excite the primary. The two secondaries have equal number of turns and are identically placed on either side of the primary winding.

The primary winding is connected to an alternating current source. A movable soft-iron core is placed inside the former. The displacement to be measured is applied to the arm attached to the soft iron core. In practice the core is made of high permeability, nickel iron. This is slotted longitudinally to reduce eddy current losses. The assembly is placed in a stainless steel housing to provide electrostatic and electromagnetic shielding. The frequency of ac signal applied to primary winding may be between 50 Hz to 20 kHz.

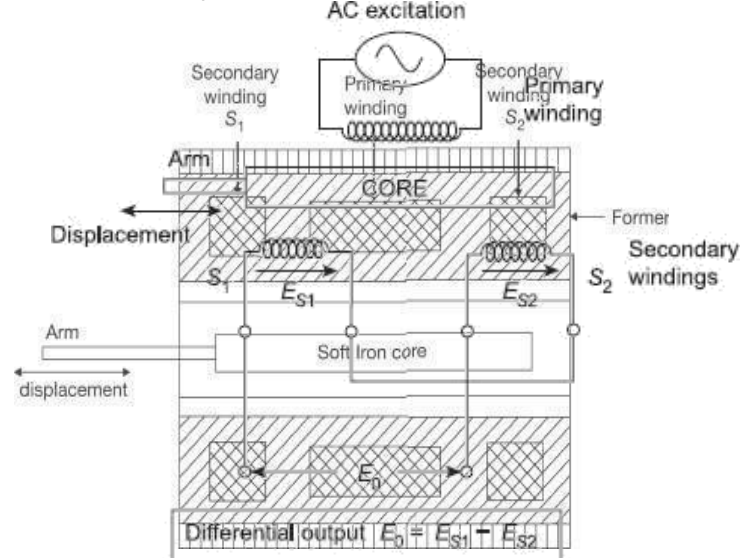

Since the primary winding is excited by an alternating current source, it produces an alternating magnetic field which in turn induces alternating voltages in the two secondary windings.

The output voltage of secondary S_1 is E_{S1} and that of secondary S_2 is E_{S2} . In order to convert the outputs from S_1 and S_2 into a single voltage signal, the two secondary S_1 and S_2 are connected in series opposition. Differential output voltage is $E_0 = E_{S1} - E_{S2}$.

Operation

When the core is at its normal (NULL) position, the flux linking with both the secondary windings is equal and hence equal emfs are induced in them. Thus, at null position: $E_{S1} = E_{S2}$. Thus, the output voltage E_0 is zero at null position.

Now if the core is moved to the left of the null position, more flux links with S_1 and less with winding S_2 . Accordingly, output voltages E_{S1} is greater than E_{S2} . The magnitude of output voltage is thus, $E_0 = E_{S1} - E_{S2}$ and say it is in phase with primary voltage.

Similarly, when the core is moved to the right of the null position E_{S2} will be more than E_{S1} . Thus the output voltage is $E_0 = E_{S1} - E_{S2}$ and 180° out of phase with primary voltage.

The amount of voltage change in either secondary winding is proportional to the amount of movement of the core. Hence, we have an indication of amount of linear motion. By noticing whether output voltage is increased or decreased, we can determine the direction of motion.

Advantages of LVDT

- Linearity is good up to 5 mm of displacement.
- Output is rather high. Therefore, immediate amplification is not necessary.
- Output voltage is stepless and hence the resolution is very good.
- Sensitivity is high (about 40 V/mm).
- It does not load the measurand mechanically.
- It consumes low power and low hysteresis loss also.

Disadvantages of LVDT

- LVDT has large threshold.
- It is affected by stray electromagnetic fields. Hence proper shielding of the device is necessary.
- The ac inputs generate noise.
- Its sensitivity is lower at higher temperature.
- Being a first-order instrument, its dynamic response is not instantaneous.

Uses of LVDTs

The following are the major applications of LVDTs.

1. It is used for measuring the displacement having a range from few mm to cm. The LVDT directly converts the displacement into an electrical signal.
2. It is also used as the secondary [transducer](#). The LVDT is used as a device for measuring the force, weight and pressure. Some of the LVDT used for measuring the load and pressure.
3. The LVDT sensor works as the main transducer, and that changes displacement to electrical signal straight.
4. Some of these transducers are used to calculate the pressure and load.
5. LVDT's are mostly used in industries as well as servomechanisms.
6. Other applications like power turbines, hydraulics, automation, aircraft, and satellites.

EXPECTED POSSIBLE QUESTIONS

1. Define strain gauge and for what this is used?
2. Explain the working principle of strain gauge briefly.
3. What is inductive transducer?
4. Explain the construction and working principle of LVDT with proper diagram.
5. Write down the advantages, disadvantages and uses of LVDT.

CAPACITIVE TRANSDUCERS

The capacitive [transducer](#) is used for measuring the displacement, pressure and other physical quantities. It is a passive transducer that means it requires external power for operation. The capacitive transducer works on the principle of variable [capacitances](#). The capacitance of the capacitive transducer changes because of many reasons like overlapping of plates, change in distance between the plates and dielectric constant. The capacitive transducer contains two parallel metal plates. These plates are separated by the dielectric medium which is air, material, gas or liquid. In the normal capacitor the distance between the plates are fixed, but in capacitive transducer the distance between them are varied.

The capacitive transducer uses the electrical quantity of capacitance for converting the mechanical movement into an electrical signal. The input quantity causes the change of the capacitance which is directly measured by the capacitive transducer.

The capacitors measure both the static and dynamic changes. The displacement is also measured directly by connecting the measurable devices to the movable plate of the capacitor. It works on with both the contacting and non-contacting modes.

Principle of Operation

The equations below express the capacitance between the plates of a capacitor

$$C = \epsilon A/d$$

$$C = \epsilon_r \epsilon_0 A/d$$

Where A – overlapping area of plates in m²

d – the distance between two plates in meter

ϵ – permittivity of the medium in F/m

ϵ_r – relative permittivity

ϵ_0 – the permittivity of free space

The schematic diagram of a parallel plate capacitive transducer is shown in the figure below.

The change in capacitance occurs because of the physical variables like displacement, force, pressure, etc. The capacitance of the transducer also changes by the variation in their dielectric constant which is usually because of the measurement of liquid or gas level.

The capacitance of the transducer is measured with the bridge circuit. The output impedance

$$X_c = 1/2\pi f c$$

of transducer is given

as Where, C –

capacitance

f – frequency of excitation in Hz.

The capacitive transducer is mainly used for measurement of linear displacement. The capacitive transducer uses the following three effects.

1. Variation in capacitance of transducer is because of the overlapping of capacitor plates.

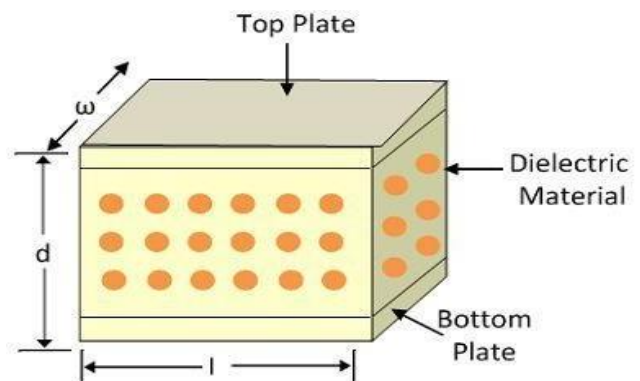

Parallel Plate Capacitive Transducer

Circuit Globe

2. The change in capacitance is because of the change in distances between the plates.
3. The capacitance changes because of dielectric constant.

The following methods are used for the measuring displacement.

1. **A transducer using the change in the Area of Plates (VARIABLE AREA CAPACITIVE TRANSDUCER) –**

The equation below shows that the capacitance is directly proportional to the area of the plates. The capacitance changes correspondingly with the change in the position of the plates.

The capacitive transducers are used for measuring the large displacement approximately from 1mm to several cms. The area of the capacitive transducer changes linearly with the capacitance and the displacement. Initially, the nonlinearity occurs in the system because of the edges. Otherwise, it gives the linear response.

The capacitance of the parallel plates is given

as
$$C = \frac{\epsilon A}{d} = \frac{\epsilon x \omega}{d} F$$

Where, x – the length of overlapping part of

plates ω – the width of overlapping part of

plates.

The sensitivity of the displacement is constant, and therefore it gives the linear relation between the capacitance and displacement.

$$S = \frac{\partial C}{\partial x} = \epsilon \frac{\omega}{d} F/m$$

The capacitive transducer is used for measuring the angular displacement. It is measured by the movable plates shown below. One of the plates of the transducer is fixed, and the other is movable.

The phasor diagram of the transducer is shown in the figure below.

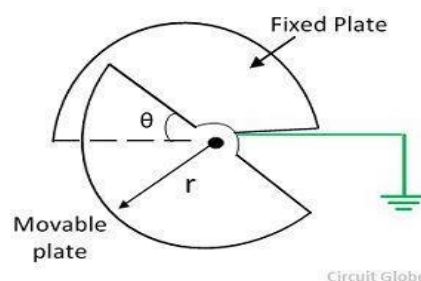
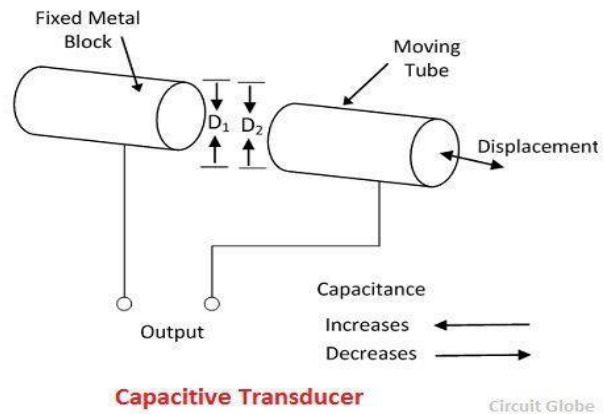

The angular movement changes the capacitance of the transducers. The capacitance between them is maximum when these plates overlap each other. The maximum value of capacitance is expressed

as

$$C_{max} = \frac{\epsilon A}{d} = \frac{\pi \epsilon r^2}{2d}$$

The capacitance at angle θ is given expressed as,

$$C = \frac{\epsilon \theta r^2}{2d}$$

θ – Angular displacement in radian. The sensitivity for the change in capacitance is given as

$$S = \frac{\partial C}{\partial \theta} = \frac{\epsilon r^2}{2d}$$

The 180° is the maximum value of the angular displacement of the capacitor.

2. The transducer using the change in distance between the plates –

The capacitance of the transducer is inversely proportional to the distance between the plates. The one plate of the transducer is fixed, and the other is movable. The displacement which is to be measured links to the movable plates.

The capacitance is inversely proportional to the distance because of which the capacitor shows the nonlinear response. Such type of transducer is used for measuring the small displacement. The phasor diagram of the capacitor is shown in the figure.

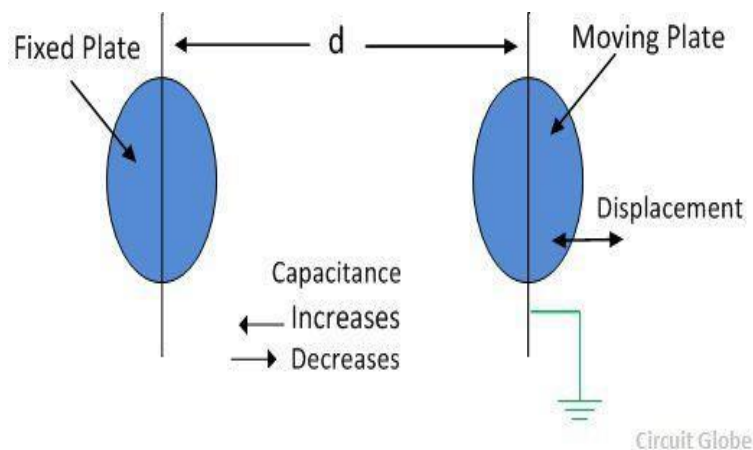

The sensitivity of the transducer is not constant and vary from places to places.

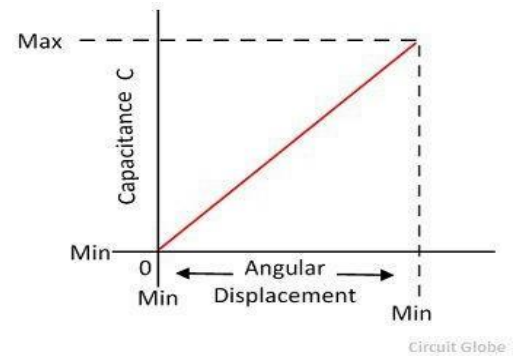

Advantage of Capacitive Transducer

The following are the major advantages of capacitive transducers.

1. It requires an external force for operation and hence very useful for small systems.
2. The capacitive transducer is very sensitive.
3. It gives good frequency response because of which it is used for the dynamic study.
4. The transducer has high input impedance hence they have a small loading effect.
5. It requires small output power for operation.

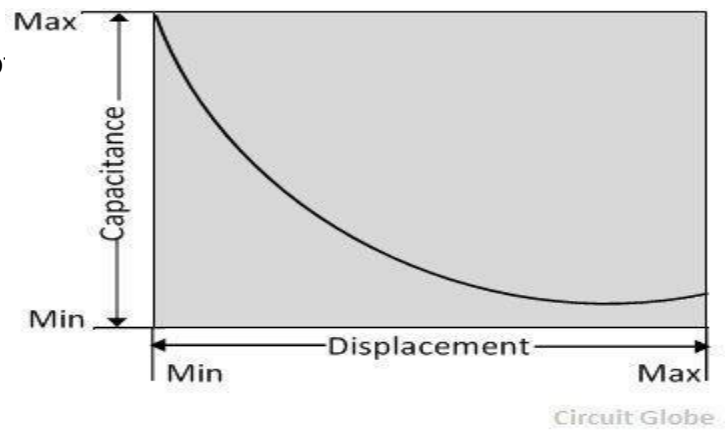

Disadvantages of capacitive Transducer

The main disadvantages of the transducer are as follows.

1. The metallic parts of the transducers require insulation.
2. The frame of the capacitor requires earthing for reducing the effect of the stray magnetic field.
3. Sometimes the transducer shows the nonlinear behaviors because of the edge effect which is controlled by using the guard ring.
4. The cable connecting across the transducer causes an error.

Uses of Capacitive Transducer

The following are the uses of capacitive transducer.

1. The capacitive transducer uses for measurement of both the linear and angular displacement. It is extremely sensitive and used for the measurement of very small distance.
2. It is used for the measurement of the force and pressures. The force or pressure, which is to be measured is first converted into a displacement, and then the displacement changes the capacitances of the transducer.
3. It is used as a pressure transducer in some cases, where the dielectric constant of the transducer changes with the pressure.
4. The humidity in gases is measured through the capacitive transducer.
5. The transducer uses the mechanical modifier for measuring the volume, density, weight etc.

The accuracy of the transducer depends on the variation of temperature to the high level.

EXPECTED POSSIBLE QUESTIONS

1. Explain the basic working principle of capacitive transducer.
2. What is Variable area capacitive transducer? Describe its working principle with proper diagram.
3. How do we change the value of capacitance by varying the distance between plates? Explain briefly.
4. Write down few advantages, disadvantages and uses of capacitive transducer.

Piezoelectric Transducers

The piezoelectric transducers work on the principle of piezoelectric effect. When mechanical stress or forces are applied to some materials along certain planes, they produce electric voltage. This electric voltage can be measured easily by the voltage measuring instruments, which can be used to measure the stress or force.

There are certain materials that generate electric potential or voltage when mechanical strain is applied to them or when the voltage is applied to them, they tend to change the dimensions along certain plane. This effect is called as the piezoelectric effect. This effect was discovered in the year 1880 by Pierre and Jacques Curie. Some of the materials that exhibit piezoelectric effect are quartz, Rochelle salt, polarized barium titanate, ammonium dihydrogen, ordinary sugar etc.

The physical quantities like stress and force cannot be measured directly. In such cases the material exhibiting piezoelectric transducers can be used. The stress or the force that has to be measured is applied along certain planes to these materials. The voltage output obtained from these materials due to piezoelectric effect is proportional to the applied stress or force. The output voltage can be calibrated against the applied stress or the force so that the measured value of the output voltage directly gives the value of the applied stress or force.

The piezoelectric effect can be made to response mechanical deformations of the material in many different modes. The modes can be thickness expansion, transverse expansion, thickness shear and face shear. The mode of motion affected depends on the shape of the body relative to the crystal axis and location of the electrodes. The mechanical deformation generates a charge and this charge appears as a voltage across the electrodes.

The magnitude and polarity of the induced surface are proportional to the magnitude and direction of the applied force F . The polarity of induced charge depends upon the direction of applied force. The charge is given by,

$$Q = d \times F$$

where d = charge sensitivity of crystal

F = applied force

Modes of Operation of Piezo-electric Crystals

There are different mode of operation they are given below:

1. Thickness shear
2. Face shear
3. Thickness expansion
4. Transverse Expansion

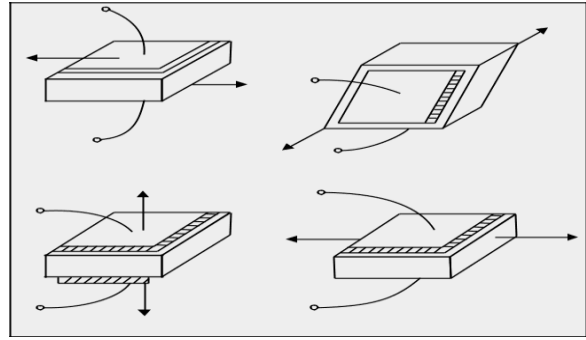

Application

They are used for quality assurance, process control and for research and development in many different industries.

Hall Effect Transducer

This transducer works on the principle of Hall Effect. When a current conducting material is placed in the transverse magnetic field then the difference of potential is produced between the opposite edges of the conductor. This effect is known as Hall Effect. The magnitude of the voltage depends upon the current, the strength of magnetic field and the property of the conductor.

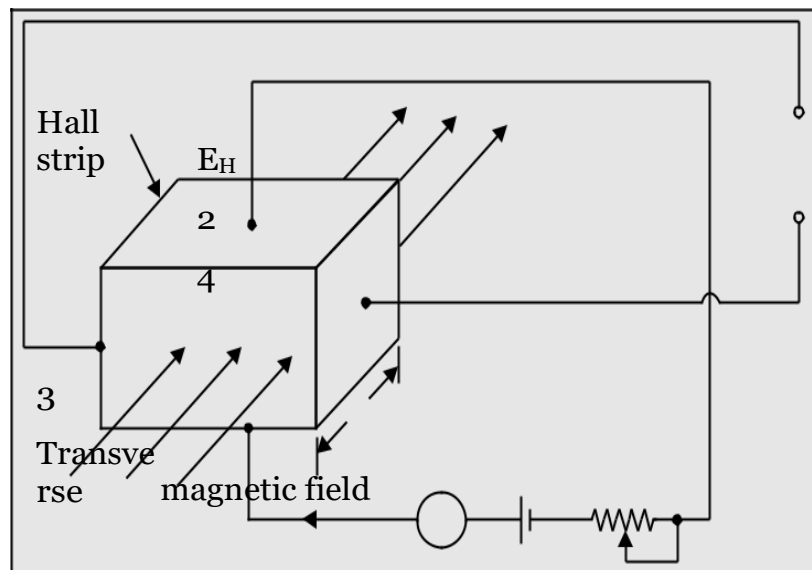

Let the current pass through edge 1 and 2 of the conductor and the output leads is connected to edge 3 and 4. The edge 3 and 4 are at same potential when there is no transverse magnetic field passing through the conductor. When a transverse magnetic field passing through the conductor, an output voltage appears across the output leads. This output voltage is proportional to the current and the field strength. The output voltage is given by,

$$E_H = K_H \cdot t \cdot I \cdot B$$

Where K_H = Hall Effect constant

t = thickness of the conductor

I = current in the circuit

B = Flux density

The voltage produced may be used for measurement of the current I or the magnetic field strength B .

Application of Hall Effect Transducers

Main applications of the Hall Effect transducers are given below:

1. Magnetic to Electric Transducer

This transducer is used as a magnetic to electrical transducer. A semiconductor plate is inserted into the magnetic field to be measured. The magnetic lines of force are perpendicular to the semiconducting plate. The transducer gives an output voltage which is proportional to the magnetic field density B . Also the element gives out a continuous electric signal in direct response to the magnetic field strength.

2. Measurement of Displacement

The Hall Effect is used for measurement of the location or displacement of the elements. The Hall Effect transducer is located in the gap adjacent to the permanent magnet. The field strength produced in the gap, adjacent to the permanent magnet in the gap, where the Hall Effect element is located, is varied by changing the position of a ferromagnetic plate. The output voltage of the Hall Effect transducer is proportional to the field strength in the gap which is a function of the position of the ferromagnetic plate from the structure.

3. Measurement of Current

The Hall Effect transducer is used to measure the current in a conductor without the need for interrupting the circuit and without making electrical connection between the conductor and the meter. The current passes through the conductor and sets up a magnetic field surrounding the conductor. The magnetic field is proportional to the current.

EXPECTED POSSIBLE QUESTIONS:

1. What is piezoelectric effect?
2. Describe the working principle of piezoelectric transducer.
3. Name the modes of operation of piezoelectric crystals.
4. What is Hall Effect? Explain the working principle of Hall Effect transducer.
5. What are the various applications of Hall Effect transducer?

TOPIC-8

OSCILLOSCOPE

The cathode ray oscilloscope (CRO) is a type of electrical instrument which is used for showing the measurement and analysis of waveforms and others electronic and electrical phenomenon. It is a very fast X-Y plotter shows the input signal versus another signal or versus time. The CROs are used to analyze the waveforms, transient, phenomena, and other time-varying quantities from a very low- frequency range to the radio frequencies.

The CRO is mainly operated on voltages. Thus, the other physical quantities like current, strain, acceleration, pressure are converted into the voltage with the help of the transducer and thus represent on a CRO. It is also used for knowing the waveforms, transient phenomenon, and other time- varying quantity from a very low-frequency range to the radio frequencies.

The CRO has Stylus (i.e., a luminous spot) which moves over the display area in response to an input voltage. This luminous spot is produced by a beam of electrons striking on a fluorescent screen. The normal form of the CRO uses a horizontal input voltage which is an internally generated ramp voltage called "time base".

The horizontal voltage moves the luminous spot periodically in a horizontal direction from left to right over the display area or screen. The vertical voltage is the voltage under investigation. The vertical voltage moves the luminous spot up and down on the screen. When the input voltage moves very fast on the screen, the display on the screen appears stationary. Thus, CRO provides a means of the visualizing time-varying voltage.

Construction of Cathode Ray Oscilloscope

The main parts of the cathode ray oscilloscope are as follows.

1. Cathode Ray Tube
2. Electronic Gun Assembly
3. Deflecting Plate
4. Fluorescent Screen For CRT
5. Glass Envelop

Their parts are explained below in details.

1. Cathode Ray Tube

The cathode ray tube is the vacuum tube which converts the electrical signal into the visual signal. The cathode ray tube mainly consists the electron gun and the electrostatic deflection plates (vertical and horizontal).The electron gun produces a focused beam of the electron which is accelerated to high frequency.

The vertical deflection plate moves the beams up and down and the horizontal beam moved the electrons beams left to right. These movements are independent to each other and hence the beam may be positioned anywhere on the screen.

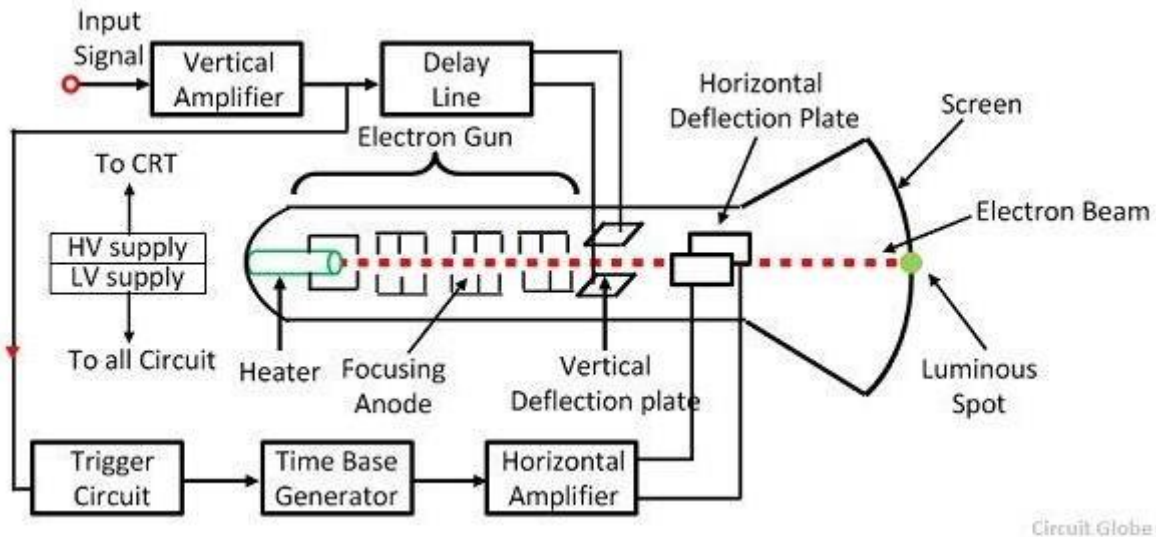

2. Electronic Gun Assembly

The electron gun emits the electrons and forms them into a beam. The electron gun mainly consists of a heater, cathode, a grid, a pre-accelerating anode, a focusing anode and an accelerating anode. For gaining the high emission of electrons at the moderate temperature, the layers of barium and strontium is deposited on the end of the cathode.

After the emission of an electron from the cathode grid, it passes through the control grid. The control grid is usually a nickel cylinder with a centrally located co-axial with the CRT axis. It controls the intensity of the emitted electron from the cathode.

The electron while passing through the control grid is accelerated by a high positive potential which is applied to the pre-accelerating or accelerating nodes.

The electron beam is focused on focusing electrodes and then passes through the vertical and horizontal deflection plates and then goes on to the fluorescent lamp. The pre-accelerating and accelerating anode are connected to 1500V, and the focusing electrode is connected to 500V. There are two methods of focusing on the electron beam. These methods are

- Electrostatic focusing
- Electromagnetic focusing.

The CRO uses an electrostatic focusing tube.

3. Deflecting Plate

The electron beam after leaving the electron gun passes through the two pairs of the deflecting plate. The pair of plate producing the vertical deflection is called a vertical deflecting plate or Y plates, and the pair of the plate which is used for horizontal deflection is called horizontal deflection plate or X plates.

4. Fluorescent Screen for CRT

The front of the CRT is called the face plate. It is flat for screen sized up to about 100mm×100mm. The screen of the CRT is slightly curved for larger displays. The face plate is formed by pressing the molten glass into a mould and then annealing it.

The inside surface of the faceplate is coated with phosphor crystal. The phosphor converts electrical energy into light energy. When an electronics beam strike phosphor crystal, it raises their energy level and hence light is emitted during phosphorous crystallization. This phenomenon is called fluorescence.

5. Glass Envelope

It is a highly evacuated conical shape structure. The inner surface of the CRT between the neck and the screen is coated with the aquadag. The aquadag is a conducting material and act as a high-voltage electrode. The coating surface is electrically connected to the accelerating anode and hence helps the electron to be the focus.

Working of Cathode Ray Oscilloscope

When the electron is injected through the electron gun, it passes through the control grid. The control grid controls the intensity of electron in the vacuum tube. If the control grid has high negative potential, then it allows only a few electrons to pass through it. Thus, the dim spot is produced on the lightning screen. If the negative potential on the control grid is low, then the bright spot is produced. Hence the intensity of light depends on the negative potential of the control grid.

After moving the control grid the electron beam passing through the focusing and accelerating anodes, the accelerating anodes are at a high positive potential and hence they converge the beam at a point on the screen.

After moving from the accelerating anode, the beam comes under the effect of the deflecting plates. When the deflecting plate is at zero potential, the beam produces a spot at the centre. If the voltage is applied to the vertical deflecting plate, the electron beam focuses at the upward and when the voltage is applied horizontally the spot of light will be deflected horizontally.

Cathode Ray Tube

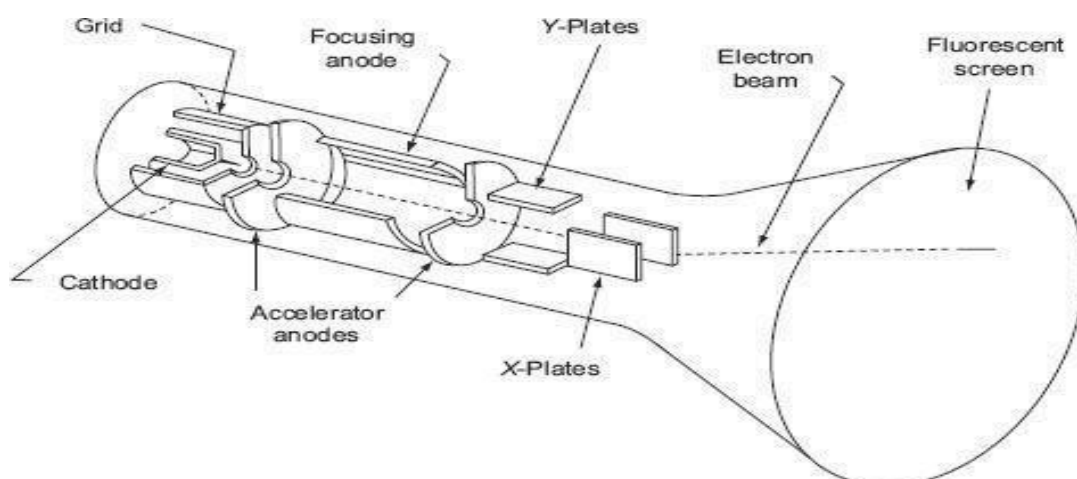

Block Diagram of CRO

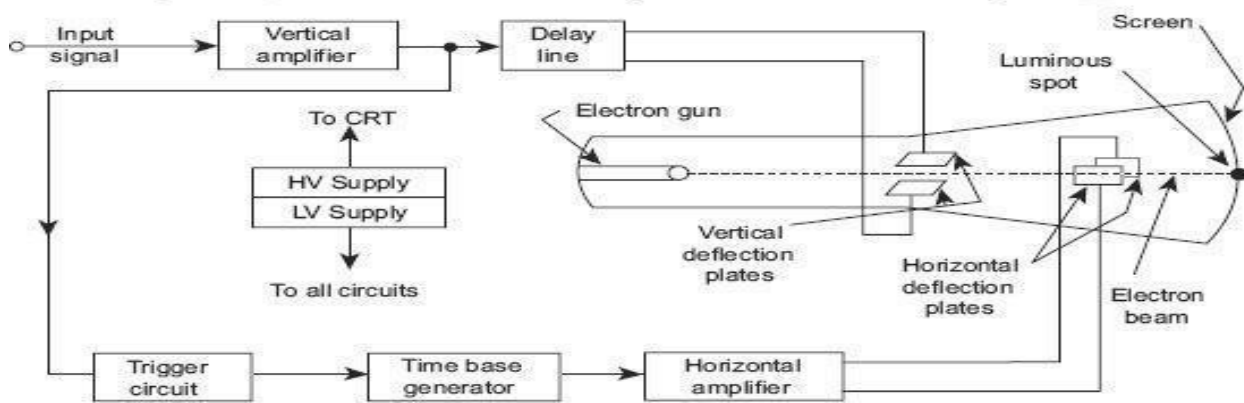

EXPECTED POSSIBLE QUESTIONS

1. What is Oscilloscope and what are its different parts and functions?
2. Explain the working principle of Cathode Ray Tube with proper diagram.
3. Explain the working principle of Oscilloscope with proper block diagram.

Measurement of DC Voltage and Current

The expression for electrostatic deflection is

$$D = \frac{Ll_d E_d}{2dE_a}, \text{ where}$$

L = distance between screen and the centre of the deflecting plates

l_d = length of deflecting plates

E_d = potential between deflecting

plates d = distance between

deflecting plates E_a = voltage of pre

accelerating anode

So deflection is proportional to the deflecting-plate voltage. Thus, the cathode ray tube will measure voltage. It is used to calibrate the tube under the given operating conditions by observing the deflection produced by a known voltage. Direct voltage may be obtained from the static deflection of the spot, alternating voltage from the length of the line produced when the voltage is applied to Y-plates while no voltage is applied to X-plates. The length of the line corresponds to the peak to peak voltage. While dealing with sinusoidal voltages, the rms value is given by dividing the peak to peak voltage by $2\sqrt{2}$.

For measurement of current, the current under measurement is passed through a known non inductive resistance and the voltage drop across it is measured by CRO, as mentioned above. The current can be determined simply by dividing the voltage drop measured by the value of non inductive

resistance. When the current to be measured is of very small magnitude, the voltage drop across non-inductive resistance (small value) is usually amplified by a calibrated amplifier.

Measurement of Frequency

It is interesting to consider the characteristics of patterns that appear on the screen of a CRO when sinusoidal voltages are simultaneously applied to the horizontal and vertical plates. These patterns are called *Lissajous patterns*.

Lissajous patterns may be used for accurate measurement of frequency. The signal, whose frequency is to be measured, is applied to the Y-plates. An accurately calibrated standard variable frequency source is used to supply voltage to the X-plates, with the internal sweep generator switched off. The standard frequency is adjusted until the pattern appears as a circle or an ellipse, indicating that both signals are of the same frequency. Where it is not possible to adjust the standard signal frequency to the exact frequency of the unknown signal, the standard is adjusted to a multiple or sub-multiple of the frequency of the unknown source so that the pattern appears stationary.

Let us consider an example. Suppose sine waves are applied to X and Y plates as shown in figure below. Let the frequency of wave applied to Y plates is twice that of the voltage applied to the X plates. This means that the CRT spot travels two complete cycles in the vertical direction against one of the horizontal direction.

The two waves start at the same instant. A Lissajous pattern may be constructed in the usual way and an 8 shaped pattern with two loops is obtained. If the two waves do not start at the same instant we get different pattern for the same frequency ratio. The Lissajous pattern for the other frequency ratios can be similarly drawn. Some of these patterns are shown in figures.

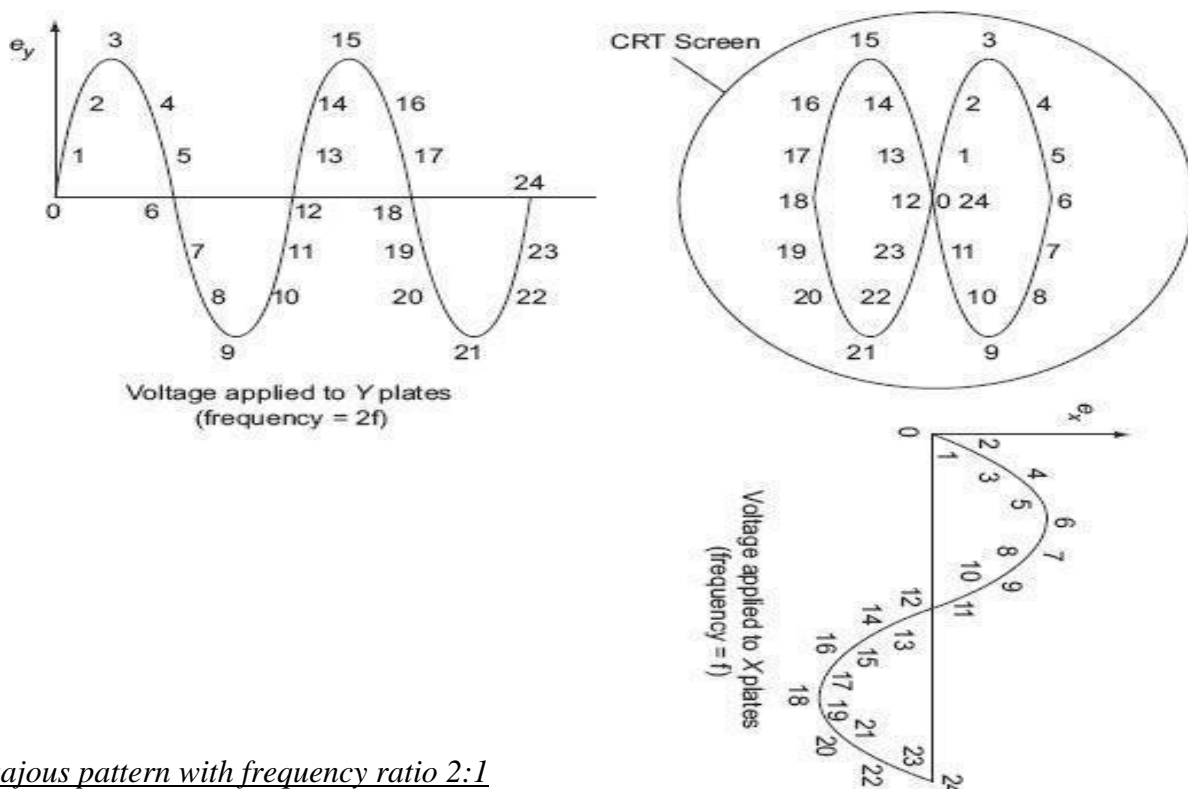

Lissajous pattern with frequency ratio 2:1

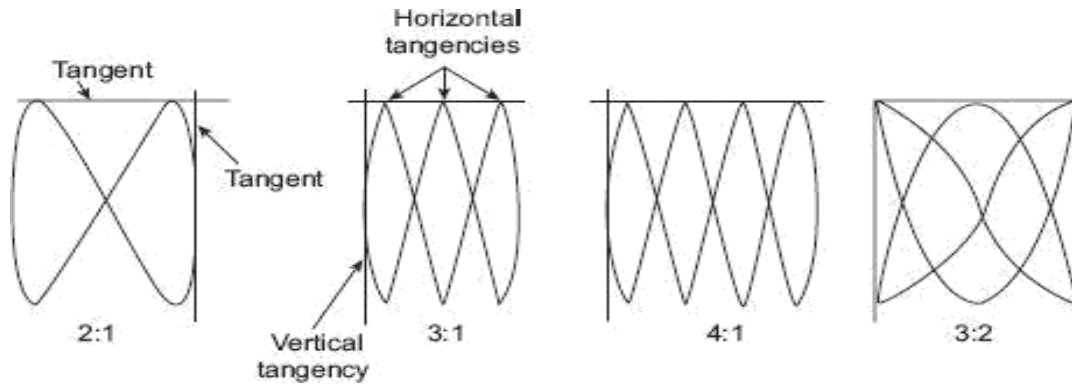

Lissajous patterns with different frequency ratio

It can be shown that for all the above cases, the ratios of the two frequencies is

$$\frac{f_y}{f_x} = \frac{\text{Number of times tangent touches top or bottom}}{\text{Number of times tangent touches either side}}$$

$$= \frac{\text{Number of horizontal tangencies}}{\text{Number of vertical tangencies}}$$

Where, f_y = Frequency of signal applied to Y plates f_x

= Frequency of signal applied to X plates

The above rule, however, does not hold for the Lissajous patterns with free ends as shown in figure. The simple rule mentioned above needs the following modifications:

Two lines are drawn, one horizontal and the other vertical so that they do not pass through any intersections of different parts of the Lissajous curve. The number of intersections of the horizontal and the vertical lines with the Lissajous curve are individually counted. The frequency ratio is given by

$$\frac{f_y}{f_x} = \frac{\text{Number of intersections of the horizontal line with the curve}}{\text{Number of intersection of the vertical line with the curve}}$$

The applications of these rules to figure give a frequency ratio $\frac{f_y}{f_x} = \frac{5}{2}$.

The modified rule is applicable in all cases whether the Lissajous pattern is open or closed.

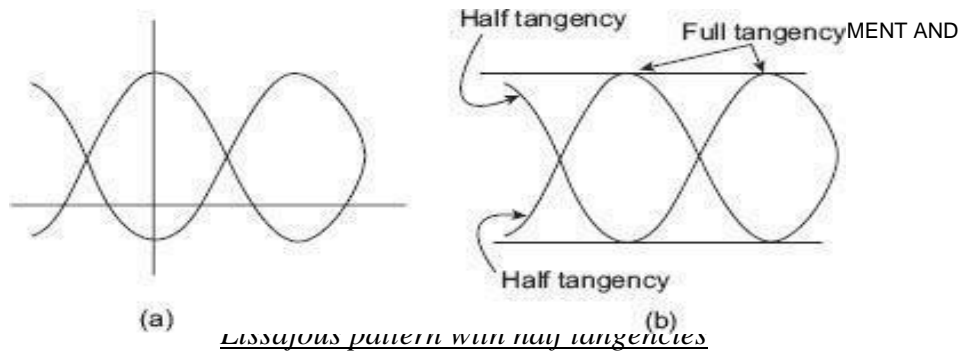

The ratio of frequencies when open ended Lissajous patterns are obtained can also be found by treating the open ends as half tangencies as shown in figure.

$$\therefore \frac{f_y}{f_x} = \frac{\text{Number of horizontal tangencies}}{\text{Number of vertical tangencies}} = \frac{2 + \frac{1}{2}}{1} = \frac{5}{2}$$

There are some restrictions on the frequencies which can be applied to the deflection plates. One obviously, is that the CRO must have the bandwidth required for these frequencies. The other restriction is that the ratio of the two frequencies should not be such as to make the pattern too complicated otherwise determination of frequency would become difficult. As a rule, ratios of as high as 10:1 and as low as 10:9 can be determined comfortably.

EXPECTED POSSIBLE QUESTIONS

1. How is the Voltage and Current of an ac signal measured with the help of CRO?
2. What are Lissajous patterns? From the Lissajous patterns, how can the frequency be measured?

