

GOVT. POLYTECHNIC, BHADRAK

Advance Manufacturing Processes Th- 04(b)

(As per the 2020-21 syllabus of the SCTE&VT,
Bhubaneswar, Odisha)



Sixth Semester

Mechanical Engg.

Prepared By: *Er Sujit kumar puhan*

ADVANCE MANUFACTURING PROCESSES .Th-04 (b)

Chapter No.	Topics	Periods as per Syllabus	Required period	Expected Marks	
01	Modern Machining Processes	20	22	07	20
02	Plastic Processing	10	12	06	15
03	Additive Manufacturing Process	15	17	07	20
04	Special Purpose Machines	07	09		15
05	Maintenance of Machine Tools	08	10		10
TOTAL		60	70	20	80

CHAPTER NUMBER -01

Modern machining process

1.1 introduction

Non-traditional manufacturing processes is defined as a group of processes that remove excess material by various techniques involving mechanical, thermal, electrical or chemical energy or combinations of these energies but do not use a sharp cutting tools as it needs to be used for traditional manufacturing processes.

Definition: A machining process is called non-traditional if its material removal mechanism is basically different than those in the traditional processes, i.e. a different form of energy (other than the excessive forces exercised by a tool, which is in physical contact with the work piece) is applied to remove the excess material from the work surface, or to separate the work piece into smaller parts.

Limitations of Conventional Machining Methods.

Increased workpiece hardness : decreased economic cuttingspeed.

Hence, lower productivity

Rapid improvements in the properties of materials (hardness, strength, etc)|

Requires much superior quality of tool materials.

Tool material hardness should be greater than workpiece hardness.

Evolution of Advanced Machining Process..

Many Engineering materials are having much superior properties such as ultra high strength , hardness, very hightemperature resistance difficult to machine by convenventional machining methods.

If work piece material hardness is greater than the toolmaterial hardness. How are we going to machine such a workpiece materiallf work piece material hardness is greater than the toolmaterial hardness. How are we going to machine such a workpiece material.

CLASSIFICATION OF ADVANCED MACHINING PROCESSES

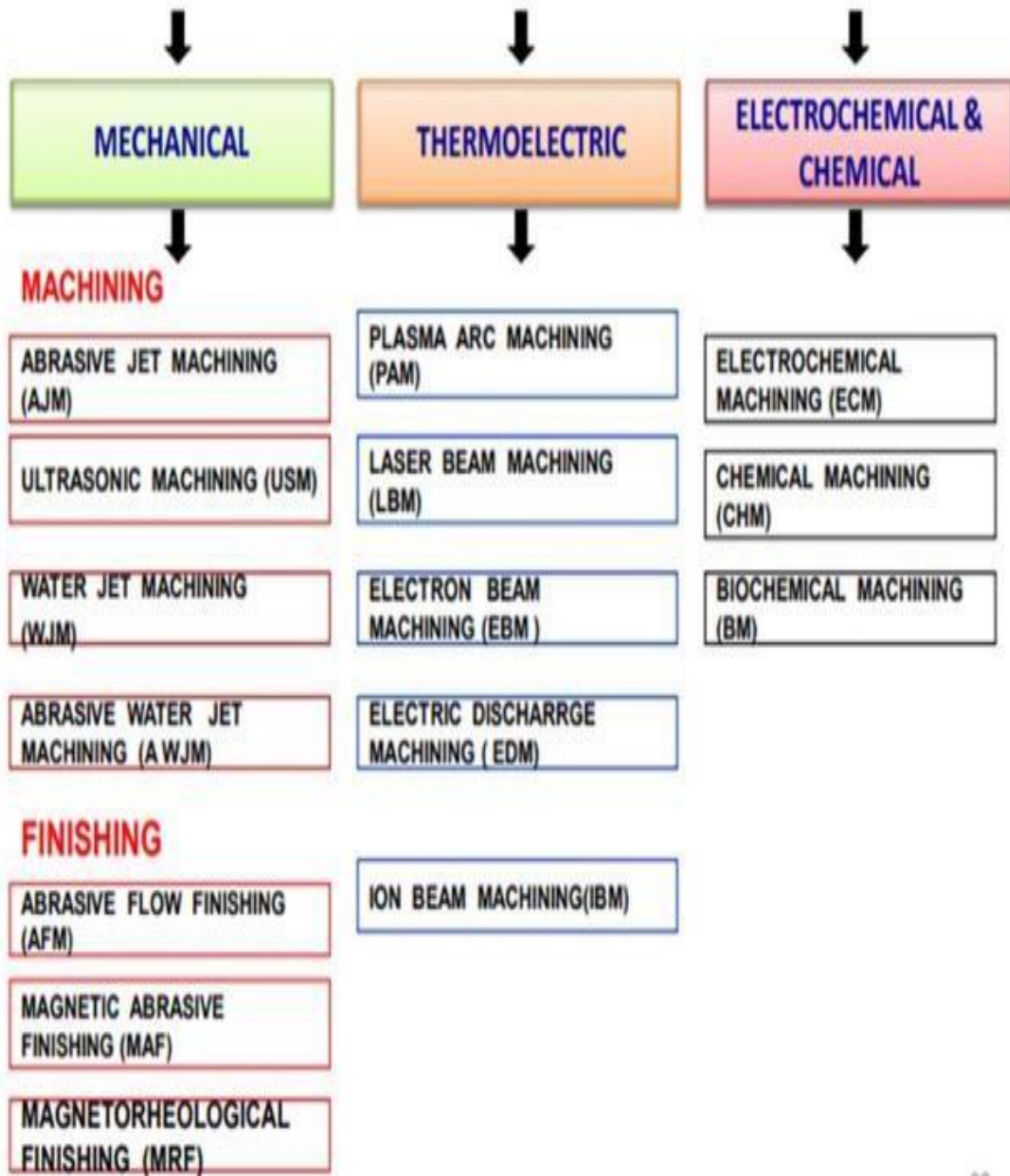

1.2-Ultrasonic Machining (USM) Process

The basic USM process involves a tool vibrating with a low amplitude and very high frequency and a continuous flow of an abrasive slurry in the small gap between tool & work piece. The tool is gradually fed with a uniform force. The impact of the hard abrasive grains fractures the hard and brittle work surface, resulting in the removal of the work material in the form of small wear particles. The tool material being tough and ductile wears out at a much slower rate.

The basic process is that a ductile and tough tool is pushed against the work with a constant force. A constant stream of abrasive slurry passes between the tool and the work (gap is 25-40 μm) to provide abrasives and carry away chips. The majority of the cutting action comes from an ultrasonic (cyclic) force applied.

USM working principle

- Material removal primarily occurs due to the indentation of the hard abrasive grits on the brittle work material.
- Other than this brittle failure of the work material due to indentation some material removal may occur due to free flowing impact of the abrasives against the work material and related solid-solid impact erosion,
- During indentation, due to Hertzian contact stresses, cracks would develop just below the contact site, then as indentation progresses the cracks would propagate due to increase in stress and ultimately lead to brittle fracture of the work material under each individual interaction site between the abrasive grits and the workpiece.
- The tool material should be such that indentation by the abrasive grits does not lead to brittle failure.
- Thus the tools are made of tough, strong and ductile materials like steel, stainless steel and other ductile metallic alloys.

The ultrasonic vibrations are produced by the transducer. The transducer is driven by suitable signal generator followed by power amplifier.

The transducer for USM works on the following principle

- Piezoelectric effect
 - Magnetostrictive effect
 - Electrostrictive effect
- Abrasive material –
- Al₂O₃
 - SiC
 - B₄C –Boronsilicarbide
 - Diamond

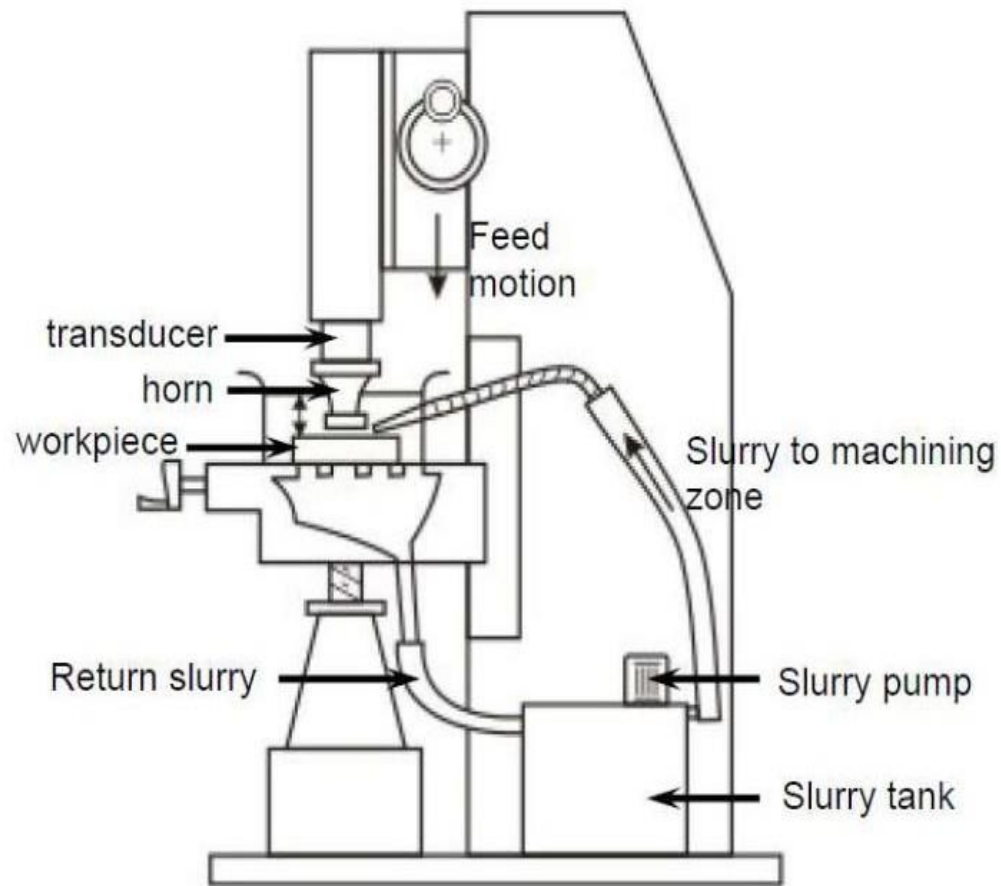

Applications of USM

- Used for machining hard and brittle metal alloys, semiconductors, glass, ceramics, carbides etc.
- Used for machining round, square, irregular shaped holes and surface impressions
- Machining, wire drawing, punching or small blanking dies.

Advantage of USM

USM process is a non-thermal, non-chemical, creates no changes in the microstructures, chemical or physical properties of the work piece and offers virtually stress free machined surfaces.

The main advantages are; ·

Any materials can be machined regardless of their electrical conductivity·

Especially suitable for machining of brittle materials· Machined parts by USM possess better surface finish and higher structural integrity.

· USM does not produce thermal, electrical and chemical abnormal surface· The main advantages are;

· Any materials can be machined regardless of their electrical conductivity· Especially suitable for machining of brittle materials· Machined parts by USM possess better surface finish and higher structural integrity·

USM does not produce thermal, electrical and chemical abnormal surface.

Disadvantages of USM·

USM has higher power consumption and lower material-removal rates than traditional fabrication processes·

Tool wears fast in USM.

· Machining area and depth is restraint in USM.

1.3-ELECTRICAL DISCHARGE MACHINING (EDM)

Electrical discharge machining (EDM) is one of the most widely used non-traditional machining processes.

The main attraction of EDM over traditional machining processes such as metal cutting using different tools and grinding is that this technique utilizes thermoelectric process to erode undesired materials from the work piece by a series of discrete electrical sparks between the work piece and the electrode.

The traditional machining processes rely on harder tool or abrasive material to remove the softer material whereas non-traditional machining processes such as EDM uses electrical spark or thermal energy to erode unwanted material in order to create desired shape. So, the hardness of the material is no longer a dominating factor for EDM process.

Working principle of EDM

At the beginning of EDM operation, a high voltage is applied across the narrow gap between the electrode and the workpiece. This high voltage induces an electric field in the insulating dielectric that is present in narrow gap between electrode and workpiece.

This cause conducting particles suspended in the dielectric to concentrate at the points of strongest electrical field. When the potential difference between the electrode and the workpiece is sufficiently high, the dielectric breaks down and a transient spark discharges through the dielectric fluid, removing small amount of material from the workpiece surface.

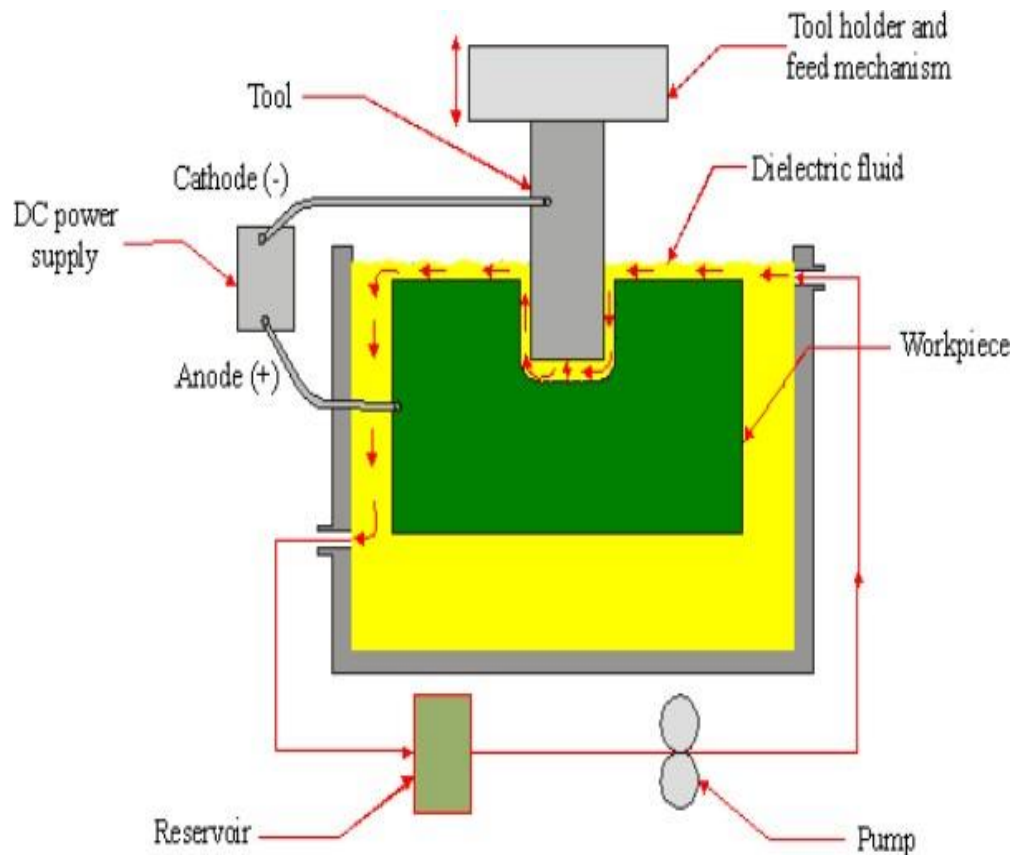

Figure: Schematic of EDM process

EDM removes material by discharging an electrical current, normally stored in a capacitor bank, across a small gap between the tool (cathode) and the workpiece (anode) typically in the order of 50 volts/10amps.

Dielectric fluids used in EDM process are hydrocarbon oils, kerosene and deionised water. The functions of the dielectric fluid are to:

- Act as an insulator between the tool and the workpiece.
- Act as coolant.
- Act as a flushing medium for the removal of the chips

1.4-Wire cut EDM

EDM, primarily, exists commercially in the form of die-sinking machines and wire-cutting machines (Wire EDM). In this process, a slowly moving wire travels along a prescribed path and removes material from the workpiece. Wire EDM uses electro-thermal mechanisms to cut electrically conductive materials. The material is removed by a series of discrete discharges between the wire electrode and the workpiece in the presence of dielectric fluid, which creates a path for each discharge as the fluid becomes ionized in the gap. The area where discharge takes place is heated to extremely high temperature, so that the surface is melted and removed. The removed particles are flushed away by the flowing dielectric fluids.

The wire EDM process can cut intricate components for the electric and aerospace industries. This non-traditional machining process is widely used to pattern tool steel for die manufacturing.

Application of EDM

The EDM process has the ability to machine hard, difficult-to-machine materials. Parts with complex, precise and irregular shapes for forging, press tools, extrusion dies, difficult internal shapes for aerospace and medical applications can be made by EDM process.

Advantages of EDM

- By this process, materials of any hardness can be machined;
- No burrs are left in machined surface;
- One of the main advantages of this process is that thin and fragile/brittle components can be machined without distortion;
- Complex internal shapes can be machined

The main limitations of this process are:

- This process can only be employed in electrically conductive materials;
- Material removal rate is low and the process overall is slow compared to conventional machining processes;
- Unwanted erosion and over cutting of material can occur;
- Rough surface finish when at high rates of material removal.

1.5 ABRASIVE JET MACHINING (AJM)

Abrasive water jet cutting is an extended version of water jet cutting; in which the water jet contains abrasive particles such as silicon carbide or aluminum oxide in order to increase the material removal rate above that of water jet machining. Almost any type of material ranging from hard brittle materials such as ceramics, metals and glass to extremely soft materials such as foam and rubbers can be cut by abrasive water jet cutting. The narrow cutting stream and computer controlled movement enables this process to produce parts accurately and efficiently. This machining process is especially ideal for cutting materials that cannot be cut by laser or thermal cut. Metallic, non-metallic and advanced composite materials of various thicknesses can be cut by this process. This process is particularly suitable for heat sensitive materials that cannot be machined by processes that produce heat while machining.

Working principle

In Abrasive Jet Machining (AJM), abrasive particles are made to impinge on the work material at a high velocity. The jet of abrasive particles is carried by carrier gas or air. The high velocity stream of abrasive is generated by converting the pressure energy of the carrier gas or air to its kinetic energy and hence high velocity jet. The nozzle directs the abrasive jet in a controlled manner onto the work material, so that the distance between the nozzle and the work piece and the impingement angle can be set desirably. The high velocity abrasive particles remove the material by micro-cutting action as well as brittle fracture of the work material.

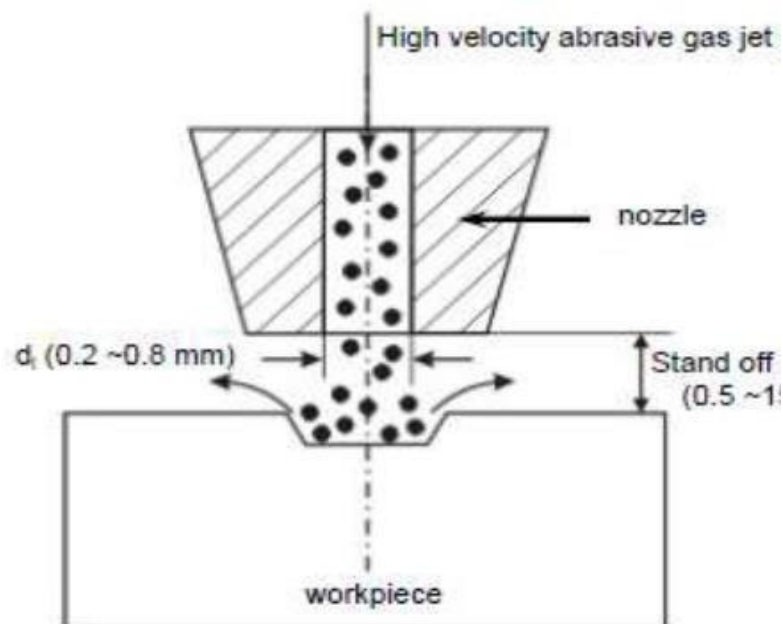

Parameters of Abrasive Jet Machining (AJM) are factors that influence its Metal Removal Rate (MRR). In a machining process, Metal Removal Rate (MRR) is the volume of metal removed from a given work piece in unit time. The following are some of the important process parameters of abrasive jet machining:

1. Abrasive mass flow rate
2. Nozzle tip distance
3. Gas Pressure
4. Velocity of abrasive particles
5. Mixing ratio
6. Abrasive grain size

Applications

♣ Abrasive water jet cutting is highly used in aerospace, automotive and electronics industries.

♣ In aerospace industries, parts such as titanium bodies for military aircrafts, engine

♣ components (aluminium, titanium, heat resistant alloys), aluminium body parts and interior cabin parts are made using abrasive water jet cutting.

♣ In automotive industries, parts like interior trim (head liners, trunk liners, and door panels) and fibre glass body components and bumpers are made by this process. Similarly, in electronics industries, circuit boards and cable stripping are made by abrasive water jet cutting.

Advantages

– In most of the cases, no secondary finishing required

– No cutter induced distortion

– Low cutting forces on work pieces

– Limited tooling requirements

– Little to no cutting burr

Limitations

• Cannot drill flat bottom

• Cannot cut materials that degrades quickly with moisture

• Surface finish degrades at higher cut speeds which are frequently used for rough cutting.

• The major disadvantages of abrasive water jet cutting are high capital cost and high

• Noise levels during operation.

LASER-BEAM MACHINING (LBM)

Laser-beam machining is a thermal material-removal process that utilizes a high-energy, coherent light beam to melt and vaporize particles on the surface of metallic and non-metallic workpieces. Lasers can be used to cut, drill, weld and mark. LBM is particularly suitable for making accurately placed holes. A schematic of laser beam machining is shown in Figure.

Different types of lasers are available for manufacturing operations which are as follows:

- CO₂(pulsed or continuous wave): It is a gas laser that emits light in the infrared region. It can provide up to 25 kW in continuous-wave mode.
- Nd:YAG: Neodymium-doped Yttrium-Aluminum-Garnet (Y₃Al₅O₁₂) laser is a solid-state laser which can deliver light through a fibre-optic cable. It can provide up to 50 kW power in pulsed mode and 1 kW in continuous-wave mode.

laser is a device that emits light through a process of optical amplification based on the stimulated emission of electromagnetic radiation.

The term "laser" originated as an acronym for: Light Amplification by Stimulated Emission of Radiation. The Lasing process describes the basic operation of laser, i.e. generation of coherent (both temporal and spatial) beam of light by "light amplification" using "stimulated emission"

.The laser differs from other incoherent light because it is: 1) Monochromatic 2) Coherent 3) Directional or collimated 4) Bright.

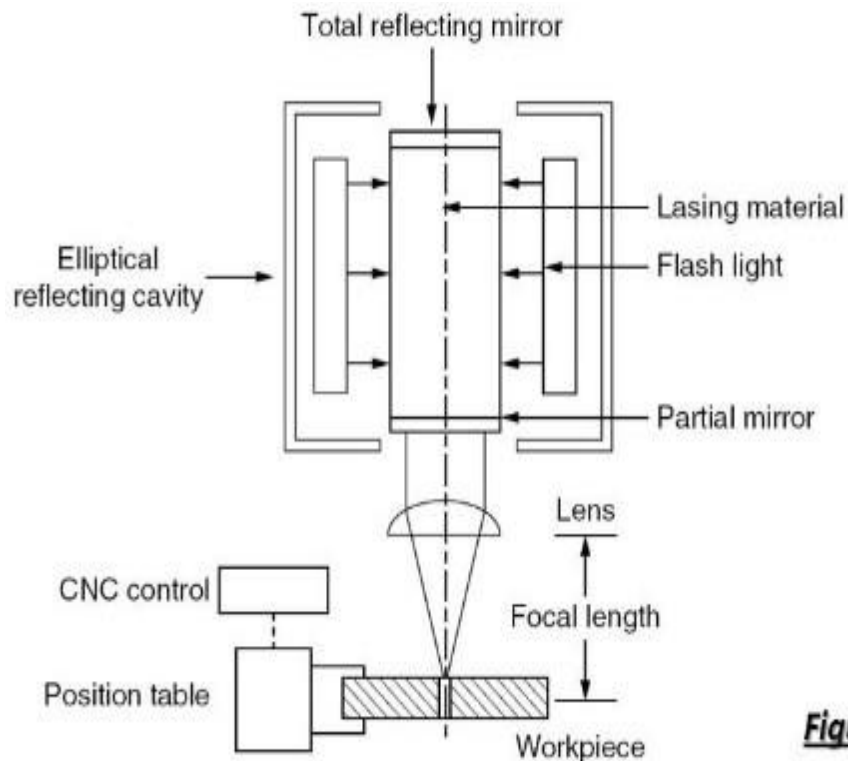

Figure 4

Principle of LASER

The electrons at ground state can be excited to higher state of energy by absorbing energy from external sources like electronic vibration at elevated temperature, through chemical reaction or by absorbing photons.

On reaching the higher energy level, the electron reaches an unstable energy band. And it comes back to its ground state within a very small time by releasing a photon. This is called spontaneous emission.

Advantage

- No limit to cutting path as the laser point can move any path
- The process is stress less allowing very fragile materials to be laser cut without any support
- Very hard and abrasive material can be cut
- Sticky materials are also can be cut by this process.
- It is a cost effective and flexible process
- High accuracy parts can be machined.
- No cutting lubricants required
- No tool wear

Limitations

- Uneconomic on high volumes compared to stamping

- Limitations on thickness due to taper
- High capital cost
- High maintenance cost
- Assist or cover gas required

ELECTROCHEMICAL MACHINING (ECM)

Electrochemical machining (ECM) is a metal-removal process based on the principle of reverse electroplating. In this process, particles travel from the anodic material (workpiece) toward the cathodic material (machining tool). A current of electrolyte fluid carries away the depleted material before it has a chance to reach the machining tool. The cavity produced is the female mating image of the tool shape.

Similar to EDM, the workpiece hardness is not a factor, making ECM suitable for machining difficult-to-machine materials. Difficult shapes can be made by this process on materials regardless of their hardness. A schematic representation of ECM process is shown in Figure 8. The ECM tool is positioned very close to the workpiece and a low voltage, high amperage DC current is passed between the workpiece and electrode. Some of the shapes made by ECM process is shown in Figure.

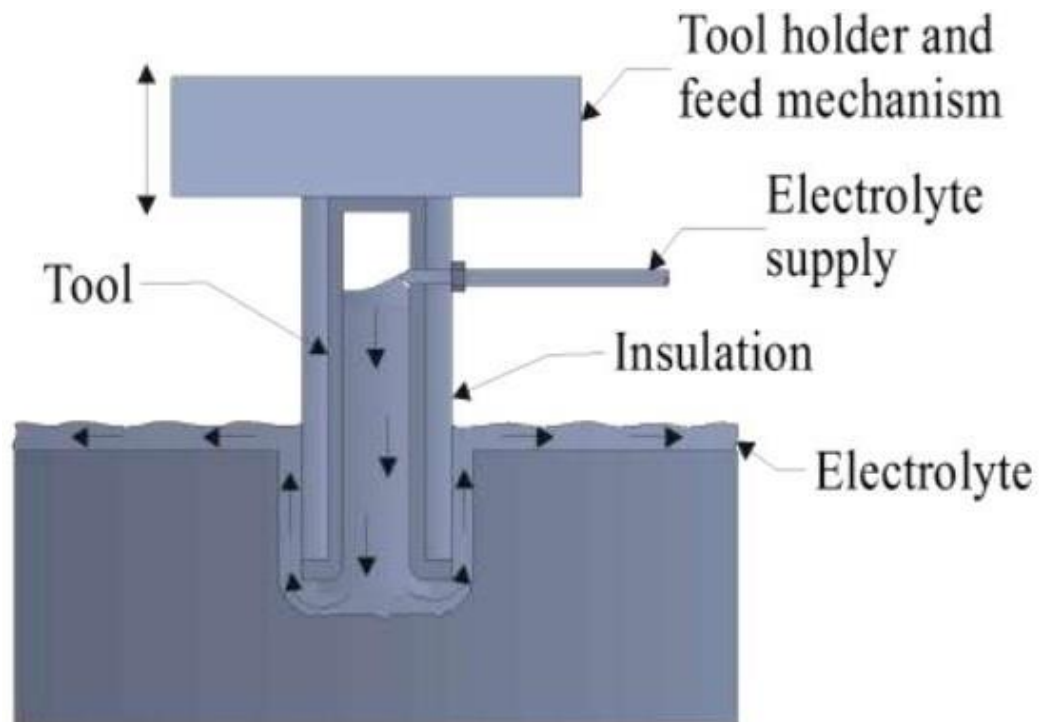

- Electrochemical machining is one of the most unconventional machining processes.

- The process is actually the reverse of electroplating with some modifications.
It is based on the principle of electrolysis. In a metal, electricity is conducted by free electrons but in a solution the conduction of electricity is achieved through the movement of ions.
- Thus the flow of current through an electrolyte is always accompanied by the movement of matter.
- In the ECM process the work-piece is connected to a positive electrode and the tool to the negative terminal for metal removal.

Advantages of ECM

- The components are not subject to either thermal or mechanical stress
- No tool wears during ECM process
- Fragile parts can be machined easily as there is no stress involved.
- ECM deburring can debur difficult to access areas of parts
- High surface finish (up to 25 µm in) can be achieved by ECM process.
- Complex geometrical shapes in high-strength materials particularly in the aerospace industry for the mass production of turbine blades, jet-engine parts and nozzles can be machined repeatedly and accurately.
- Deep holes can be made by this process.

Limitations of ECM

- ECM is not suitable to produce sharp square corners or flat bottoms because of the tendency for the electrolyte to erode away sharp profiles.
- ECM can be applied to most metals but, due to the high equipment costs, is usually used primarily for highly specialised applications.

Applications of ECM

- Die sinking
- Profiling and contouring
- Trepanning Grinding,
- Drilling and Micro-machining

Plasma Arc Machining

- Plasma Arc Machining is used to remove material from the workpiece. In this process, a high velocity jet of high-temperature gas is used to melt and remove material from the workpiece. This high velocity of hot gas is also known as plasma jet.
- When a gas or air is heated at a temperature of more than 5000 °C, then it will start getting ionized into positive ions, negative ions and neutral ions. When the gas or air is ionized its temperature reaches from 11000 °C to 28000 °C and this ionized gas is called plasma.
- The gas or air is heated with arc and the plasma produced by heating gas is used to remove material from the workpiece. So the whole process is called Plasma Arc Machining.
- In this process, a high velocity of high temperature air is used to remove material from the workpiece by melting it.

Working principle

PAM process uses ionized plasma to transfer heat. The plasma is obtained by forcing gas through an electric arc generated between cathode and anode.

The high temperature plasma jet melts the metal and removes material from the workpiece.

Plasma Gun:

Different gases like nitrogen, hydrogen, argon or mixture of these gases are used to create plasma. This plasma gun has a chamber which has a tungsten electrode. This tungsten electrode is connected to the negative terminal and nozzle of the plasma gun is connected to the positive terminal of the DC power supply. The required mixture of gas is supplied to the gun. A strong arc is produced between the anode and the cathode.

DC Power Supply is used to develop two terminals in the plasma gun. Heavy potential difference is applied across cathode and anode so that arc produced is strong and is able to ionize the gas mixture and convert it into plasma.

Different materials can be worked using this plasma arc machining. Different metals like aluminum, magnesium, carbon, stainless steel and alloy steels can be worked using this process.

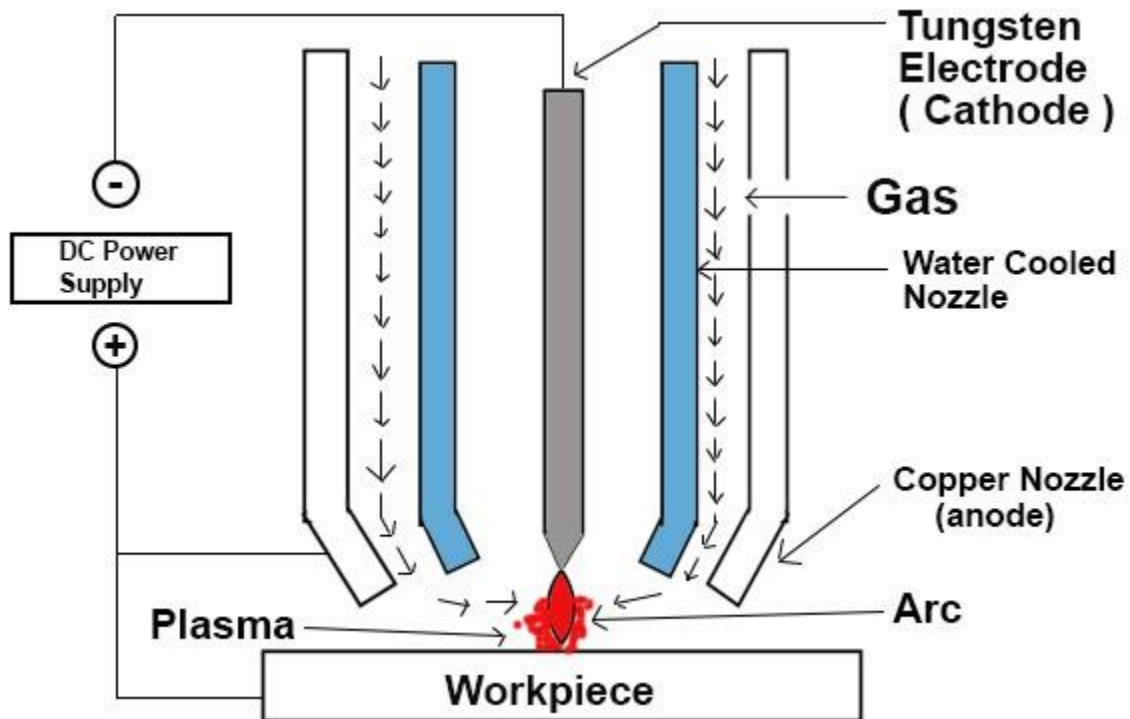

The plasma arc cutting torch carries a tungsten electrode fitted in the chamber. This tungsten electrode is connected to the negative terminal of the DC power supply. For plasma arc machining, a plasma gun is required. This plasma gun has a chamber. This plasma gun has a tungsten electrode fitted inside the chamber. This tungsten electrode is connected to the negative terminal of DC Power Supply and acts as a cathode. At the bottom of the chamber, there is a copper nozzle that is connected to a positive terminal of the DC Power Supply and acts as an anode. The rest of the chamber is made of insulating material and acts as an insulator. Gas enters the chamber through a small passage present at the right side of the chamber. The cathode and the anode remain cool despite the hot gases passing through them as they are water cooled. Water circulation is present around the torch.

At first, when a D.C power is supplied to the circuit, a strong arc is produced between the cathode (electrode) and the anode (nozzle). After that, gas is supplied to the chamber. This gas can be hydrogen, nitrogen, argon or mixture of these gases chosen according to the metal to be worked. The gas used in the process is heated using the arc produced between the cathode and the anode. This gas is heated to very high temperatures from 11000 °C to 28000 °C. As the arc comes into contact with the gas, there is a collision between the electron of the arc and the molecules of the gas and the molecules of the gas will dissociate into separate atoms.

Due to the high high temperature generated from the arc, electrons from some atoms will be displaced and atoms are ionized (electrically charged) and the gas turns into

plasma. As the gas is ionized, a large amount of thermal energy is liberated. After the gas is ionized, this high temperature ionized gas is directed towards the workpiece with high velocity. The electric arc has some other benefits like it increases the temperature of ionized gas, makes the beam almost parallel, and increases the velocity of the gas. As the plasma jet reaches the workpiece, the plasma melts the workpiece and the high-velocity gas blows away the molten metal. In this way, plasma arc machining is used to remove material from the workpiece.

Advantages

- Hard as well as brittle metals can be easily machined with this process.
- Plasma Arc Machining gives a faster production rate. Small cavities can be machined using this process with good dimensional accuracy.
- It can be used for rough turning of very hard materials.
- It is also used in machines that are used to repair jet engine blades.

Limitations

- The equipment used in Plasma Arc Machining are very costly.
- Metallurgical changes take place on the surface of the workpiece.
- The consumption of inert gas is high.
- As oxidation and scale formation takes place, shielding is required.

Applications

- It is used in mill applications.
- It is also used in the nuclear submarine pipe system.
- Used in welding rocket motor case.
- Used in welding of stainless steel tubes.

Electron Beam Machining

Electron Beam Machining is a non-traditional machining process in which no physical tool is used. Electron beam machining is same as laser beam machining process in which except laser, high speed electron beam impinges on work piece. This will generate high heat energy and melts and vaporize metal from work piece. This whole process takes place in vacuum chamber. It is mostly used to drill holes in any shape.

This machining process works on basic principle of conversion of kinetic energy of electron into heat energy. When a high speed electron impinges on a work piece, they convert its kinetic energy into heat energy. This heat energy used to vaporize material at contact surface. This process is carried out in vacuum otherwise the electron will collide with air particle and loses its energy before impinging on work material. This is basic principle of EBM machining.

Electron Gun

It is called heart of electron beam machining. It is used to generate electron. It is simply a cathode ray tube which generates electron, accelerate them to sufficient velocity and focus them at small spot size. In this gun cathode is made by tungsten or tantalum. This cathode filament heated upto 2500 degree centigrade which accelerate to electron emission by thermionic reaction. There is very low vacuum in the chamber.

Grid

It is just after the electron gun. It is a anode which is connected by the negative bias so the electron generated by the cathode do not diverge from its path and approach to the next element. When the electrons leave this section, the velocity of electron is almost half the velocity of light.

Magnetic Lenses.

After the anode, magnetic lenses are provided which shape the beam and does not allow to diverge electron or reduce the divergence of beam. These lenses allow to pass only convergent electron, thus a high focused beam is obtained. They also capture low energy electron, thus increase the quality of beam.

Electromagnetic lens and deflection coil

Electromagnetic lens is used to focus the electron beam at a spot. They use to focus beam at a spot on work piece so a high intense beam reaches at work surface, which produces more heat and improve machining. The deflecting coil does not allow to beam deflect and take care of all electrons moves in series thus form a high intense beam.

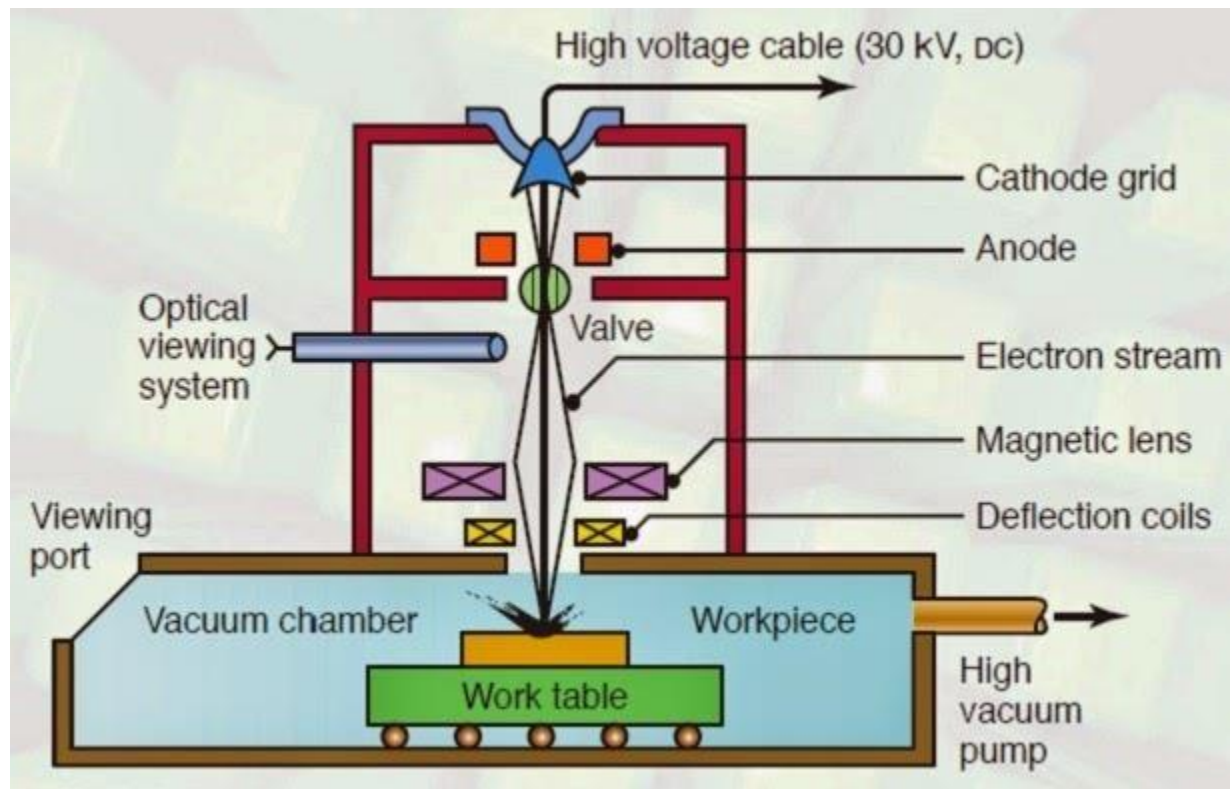

- First electron gun produces high velocity electron particles. These electron particles move towards anode which is placed after cathode tube.
- Now this high intense electron beam passes through magnetic lenses. There are a series of lenses which take care of only convergent electron passes through it. It absorb all divergent electron and low energy electron. It provides a high quality electron beam.
- This electron beam now passes through electromagnetic lens and deflecting coil. It focus the electron beam at a spot.
- The high intense electron beam impinges on the work piece where kinetic energy of electrons convert into thermal energy.
- The material is removed from contact surface by melting and vaporization due to this high heat generated by conversion of kinetic energy into thermal energy. This whole process take place in a vacuum chamber otherwise these electron collide with air particle between path and loses its kinetic energy.

Application:

- It is used to produce very small size hole about 100 micro meters to 2 millimeter.
- It is used to produce holes in diesel injection nozzle.
- Used in aerospace industries for producing turbine blade for supersonic engines and in nuclear reactors.

Advantages:

- It can be used for produce very small size hole in any shape.
- It can machining any material irrespective its hardness and other mechanical properties.
- It provides good surface finish. No any surface finishing process is require after EBM.
- Highly reacting material can be machine easily because machining is done under vacuum.

Disadvantages:

- High capital cost.
- High skill operator required.
- Low material removal rate.
- Regular maintenance is required
- Material removal rate is very low compare to other conventional process.
- It is difficult to produce perfect vacuum.

This is all about electron beam machining principle, working, equipment's, application, advantages and disadvantages with its diagram.

THE END

POSSIBLE QUESTIONS

Short question

1. What is the difference between traditional and nontraditional machining process?
2. What is plasma?
3. Define LASER.
4. Explain the use of dielectric in EDM process?
5. Explain the use of servo controller in EDM process?
6. Explain the main components of electron gun.
7. What is monochromatic light?
8. What are the abrasive materials?

Long question

1. Explain the working principle of EDM.
2. Explain the working principle of ECM.
3. Explain the working principle of PAM.
4. Explain the working principle of EBM.
5. Explain the working principle of LBM.
6. Explain the working principle of AJM.
7. Explain the working principle of USM.

CHAPTER NO- 02

Processing of plastics

1.1- Processing of plastics

Plastic processing can be defined as the process of converting the plastics raw material into semi-finished products. Process ability is generally the ease or difficulty with which a plastic can be handled during its fabrication into film, moulded products, pipe, profile etc.

Plastics can be processed with the following methods: machining, compression molding, transfer molding, injection molding, extrusion, rotational molding, blow molding, thermoforming, casting, forging, and foam molding.

Plastics are mainly organic polymers of high molecular mass, but they sometimes contain other substances as well. Plastics are usually synthetic, most commonly derived from petrochemicals, but many are partially natural. Plastics are usually classified by their chemical structure of the polymer's backbone and side chains. Some important groups in these classifications are the acrylics, polyesters, silicones, polyurethanes, and halogenated plastics. There are a variety of methods used to process plastic. Each method has its advantages and disadvantages and is better suited for specific applications.

types of molding

Injection Molding

Injection molding is a manufacturing process for producing parts by injecting material into a mold. The main method used for processing plastic is injection molding. With this process, the plastic is placed into a hopper. The hopper then feeds the plastic into a heated injection unit, where it is pushed through a long chamber with a reciprocating screw. Here, it is softened to a fluid state. A nozzle is located at the end of the chamber. The fluid plastic is forced through the nozzle into a cold, closed mold. The halves of the mold are held shut with a system of clamps. When the plastic is cooled and solidified, the halves open and the finished product is ejected from the press.

The main method used for processing plastic is injection molding. With this process, the plastic is placed into a hopper. The hopper then feeds the plastic into a heated injection unit, where it is pushed through a long chamber with a reciprocating screw. Here, it is softened to a fluid state.

A nozzle is located at the end of the chamber. The fluid plastic is forced through the nozzle into a cold, closed mold. The halves of the mold are held shut with a system of clamps. When the plastic is cooled and solidified, the halves open and the finished product are ejected from the press.

Thermosetting materials usually are not processed with injection molding because they will soften, they harden to an infusible state. If they are processed with injection molding, they need to be moved through the heating chamber quickly so they do not set.

Reaction Injection Molding

Reaction injection molding, or RIM, is one of the newer processes used in the plastics industry. It differs from liquid casting in that the liquid components are mixed together in a chamber at a lower temperature of only about 75 to 140 degrees Fahrenheit before it is injected into a closed mold. Here, an exothermic reaction occurs. As a result, RIM requires less energy than other injection molding systems. Reinforced RIM, or R-RIM, involves adding materials such as milled or chopped glass fiber in the mixture in order to increase the stiffness.

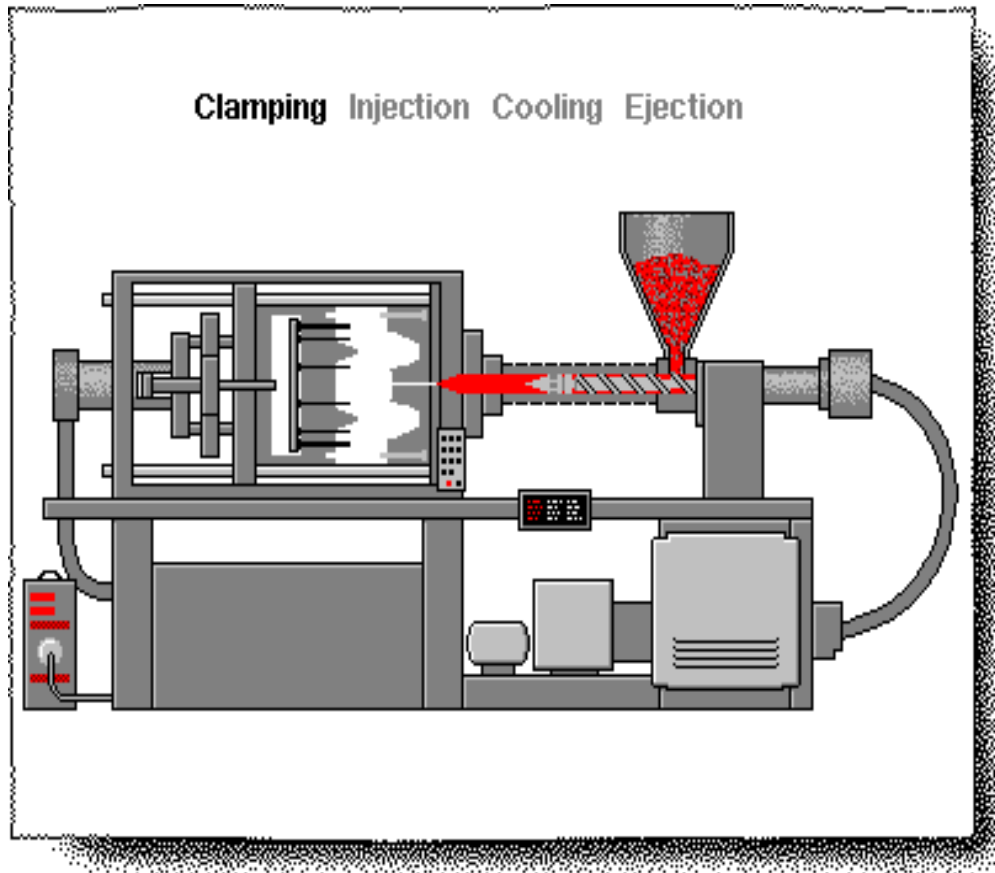

Compression Molding

Compression molding is the most common process used with thermosetting materials and is usually not used for thermoplastics. With this process, the material is squeezed into its desired shape with the help of pressure and heat. Plastic molding powder and other materials are added to the mix in order to create special qualities or to strengthen the final product. When the mold is closed and heated, the material goes through a chemical change that causes it to harden into its desired shape. The amount temperature, amount of pressure, and length of time utilized during the process depends on the desired outcome.

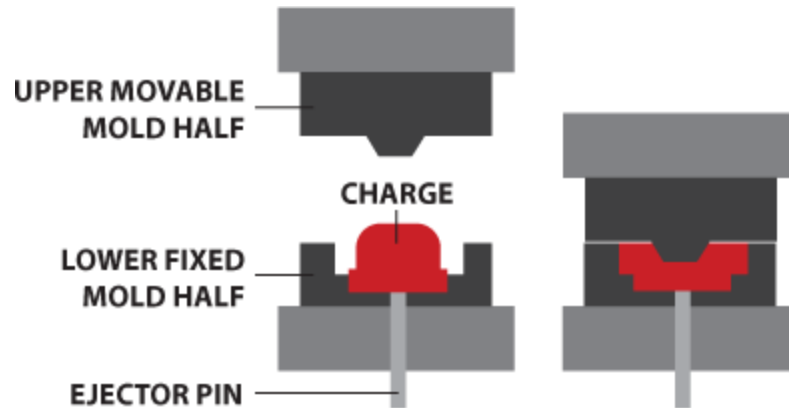

Transfer Molding

Transfer molding is generally used only for forming thermosetting plastics. It is similar to compression molding because the plastic is cured into an infusible state through pressure and heat. Unlike compression molding, however, transfer molding involves heating the plastic to a point of plasticity prior to being placed into the mold. The mold is then forced closed with a hydraulically operated plunger.

Transfer molding was initially developed as a method for molding intricate products, such as those with many metal inserts or with small, deep holes. This is because compression molding sometimes disturbed the position of the metal inserts and the holes of these types of products. With transfer molding, on the other hand, the liquefied plastic easily flows around the metal parts without causing them to change position.

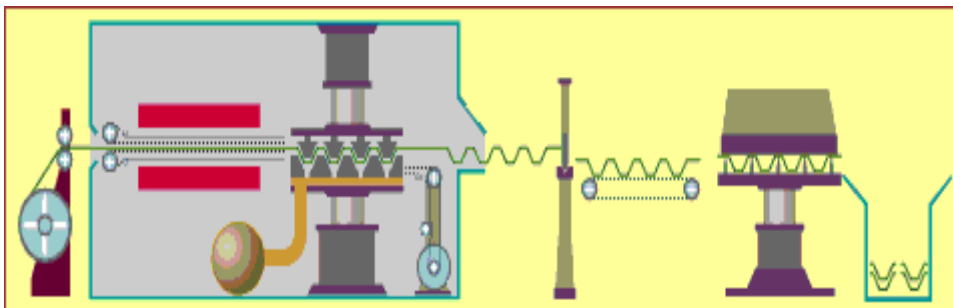

2.3-Extruding

Plastics extrusion is a high volume manufacturing process in which raw plastic material is melted and formed into a continuous profile. The process of extrusion is usually used to make products such as film, continuous sheeting, tubes, profile shapes, rods, coat wire, filaments, cords, and cables. As with injection molding, dry plastic material is placed into a hopper and fed into a long heating chamber. At the end of the chamber, however, the material is forced out of a small opening or a die in the shape of the desired finished product. As the plastic exits the die, it is placed on a

conveyor belt where it is allowed to cool. Blowers are sometimes used to aid in this process, or the product may be immersed in water to help it cool.

As the extrusion leaves the die it is cooled by passing through a cooling trough containing cold water.

→ Thicker cross-sections are extruded more slowly as more time is required for the initial heating and subsequent cooling of the larger quantities of material which are involved.

→ The tapered screw compacts the plastic as it becomes elasticized. The die which is fitted to the end of the extruder barrel determines the cross-section of the extrusion.

→ Thermoplastic granules are fed from a hopper by a rotating screw through a heated cylinder.

→ Ex: - Window frames, hose pipe, curtain track, garden trellis.

→ Continuous process used to produce both solid and hollow products that have a constant cross-section.

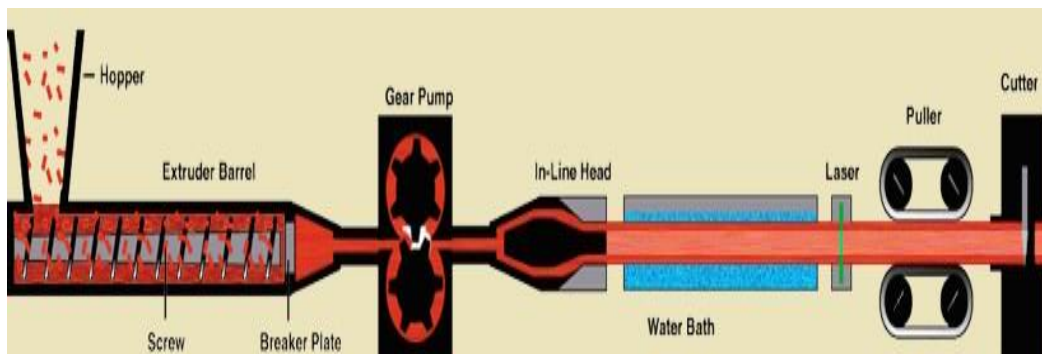

Calendaring

Calendaring is a continuous process which works in much the same way as an old-fashioned clothes mangle. For plastics, there are usually four heated rollers of different sizes rotating at slightly different speeds. The material is fed into these rollers, heated and melted, then shaped into a sheet or film. This is then cooled and rolled up. The sheets can be mono-oriented during this process. The most commonly calendared material is PVC.

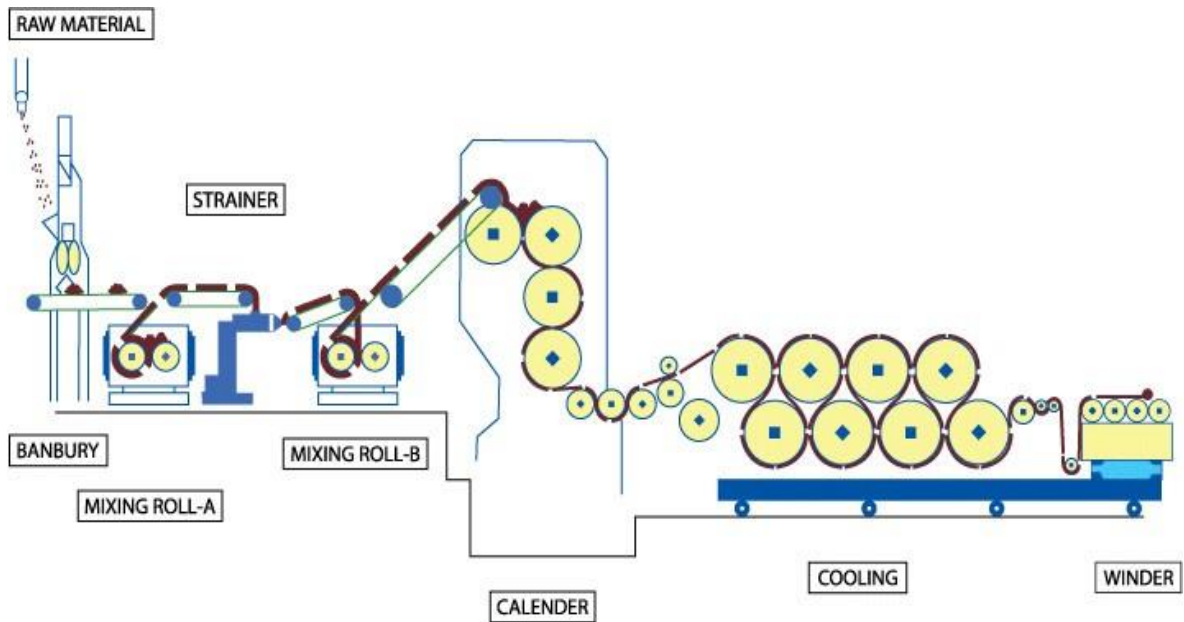

Rolls of semi-rigid PVC which will be used to manufacture transparent A4 folder 'pockets

↳ Nip rollers control the thickness of the sheet material can be gradually reduced in thickness.

↳ The process begins with the ingredients being blended and fluxed in a mixing mill at approx. 100°C.

↳ Involves rolling out a mass of premixed plastics material between large rollers to form a continuous and accurately sized film.

↳ Only used for thermoplastics.

↳ It is an intermediate process where the extruded plastic sections are reduced to sheet.

2.4-Fabrication of plastic methods

Sheet metal forming

Sheet metal forming is a process where pieces of sheet metal are modified to its geometry rather than removing any materials. The applied process generates a force that stresses the material to deform. This in turn gives the possibility to bend and stretch the sheet to a variety of complex shapes.

With the use of the industrial manufacturing process, sheet metal is formed by working metal into flat and thin pieces. Sheet metal is one of the very convenient ways that is used in metal working and it can be mended and cut into various shapes and dimensions. A wide range of products are manufactured with the use of sheet metal making it an essential part of the modern world. Sheet metal varies in thickness. Its thickness is quantified by a measure known as its gauge. The metal will be thin if the gauge number is larger.

Blow molding.

Stretch Blow Molding process is mainly used when the plastic product that needs to be created should be hollow. A molten tube is created with blow molding by using compressed air, which blows up the tube and forces it to conform to the chilled mold. Variations of blow molding include injection, injection-stretch, and extrusion blow molding.

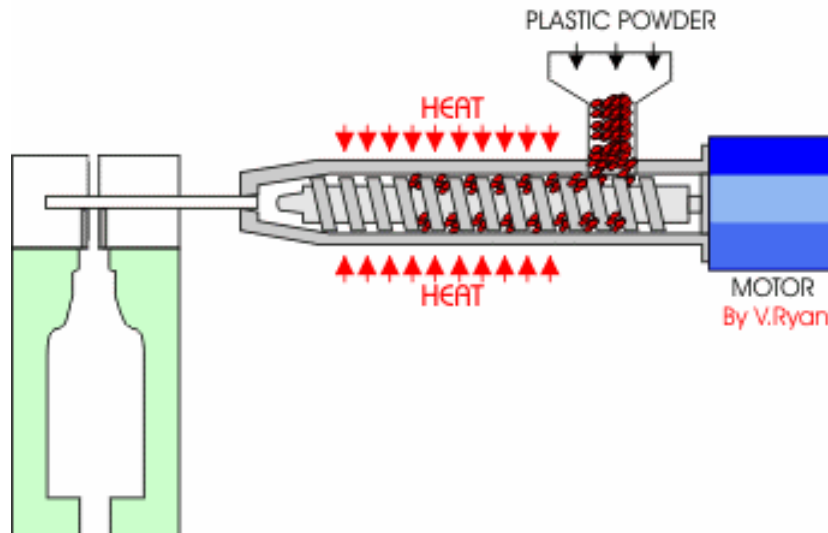

Laminated plastics

Laminated plastics are a special form of polymer-matrix composite consisting of layers of reinforcing materials that have been impregnated with thermosetting resins, bonded together, and cured under heat and pressure.

Laminated plastics are a special form of polymer-matrix composite consisting of layers of reinforcing materials that have been impregnated with thermosetting resins, bonded together, and cured under heat and pressure. Laminated plastics are available in sheet, tube, and rod shapes that are cut and/or machined for various end uses. The

same base materials are also used in molded-laminated and molded-macerated parts. The molded-laminated method is used to produce shapes that would be uneconomical to machine from flat laminates, where production quantities are sufficient to warrant mold costs.

Resins: Phenolics are the most widely used resin in laminated plastics. These low-cost resins have good mechanical and electrical properties and resistance to heat, flame, moisture, mild acids, and alkalis. Most paper and cloth-reinforced laminates are made with phenolics. Malemine resins are used primarily in electrical-grade laminates because of their excellent resistance to arcing and tracking, high mechanical strength, and good resistance to alkalis.

Reinforcements: Papers are the lowest-cost reinforcing materials used in making laminates. Types include kraft, alpha, cotton linter, and combinations of these. Papers provide excellent electrical properties, good dimensional stability, moderate strength, and uniform appearance. Cotton cloth is used for applications requiring good mechanical strength. The lighter-weight fabrics are not as strong but have excellent machinability. Glass-fiber reinforcements, in woven fabric or mat, form the strongest laminates. These laminates also have low moisture absorption and excellent heat resistance and electrical properties. Nylon fabrics provide excellent electrical and mechanical properties and chemical resistance, but laminates reinforced with these materials lack dimensional stability at elevated temperatures.

Applications of plastics

Engineering applications for plastics include mechanical units under stress, low friction components, heat and chemical resistant units, electrical parts, housings, high light transmission applications, building construction functions, and many miscellaneous uses. Plastic is used across almost every sector, including producing packaging, in building and construction, in textiles, consumer products, transportation, electrical and electronics and industrial machinery.

POSSIBLE QUESTIONS

Short question

1. What is plastic process?
2. What is reaction moulding?
3. Define resins.

Long questions

1. Write short notes

1. Injection moulding
2. Calendaring
3. Extruding
4. Transfer moulding
5. Reinforcements

CHAPTER NUMBER -03

ADDITIVE MANUFACTURING PROCESS

INTRODUCTION

Additive Manufacturing (AM) refers to a process by which digital 3D design data is used to build up a component in layers by depositing material.

Additive manufacturing (AM) or additive layer manufacturing (ALM) is the industrial production name for 3D printing, a computer controlled process that creates three dimensional objects by depositing materials, usually in layers.

Additive manufacturing process

1. CAD

The most common method for producing a digital model is computer-aided design (CAD). There are a large range of free and professional CAD programs that are compatible with additive manufacture. Reverse engineering can also be used to generate a digital model via 3D scanning.

2. STL conversion and file manipulation

A critical stage in the additive manufacturing process that varies from traditional manufacturing methodology is the requirement to convert a CAD model into an STL (stereo lithography) file. STL uses triangles (polygons) to describe the surfaces of an object. A guide on how to convert a CAD model to an STL file can be found . Once a STL file has been generated the file is imported into a slicer program. This program takes the STL file and converts it into G-code. G-code is a numerical control (NC) programming language. It is used in computer-aided manufacturing (CAM) to control automated machine tools (including CNC machines and 3D printers).

3. Printing

3D printing machines often comprise of many small and intricate parts so correct maintenance and calibration is critical to producing accurate prints. At this stage, the print material is also loaded into the printer. The raw materials used in additive manufacturing often have a limited shelf life and require careful handling. While some processes offer the ability to recycle excess build material, repeated reuse can result in a reduction in material properties if not replaced regularly.

4. Removal of prints

For 3D printing methods the removal of a print is a highly technical process involving precise extraction of the print while it is still encased in the build material or attached to the build plate. These methods require complicated removal procedures and highly skilled machine operators along with safety equipment and controlled environments.

needs for additive manufacturing

Additive manufacturing provides a cost-effective and time-efficient way to produce low-volume, customized products with complicated geometries and advanced material properties and functionality.

Implemented properly, additive manufacturing can significantly reduce material waste, reduce the amount of production steps, inventory being held, and reduce the amount of distinct parts needed for an assembly.

Fundamentals of additive manufacturing

The progress of additive manufacturing processes is ever increasing with the development of the digital platform in the manufacturing sector, which is essential for the growth of modern technologies. This course is primarily designed for fundamental understanding of different additive manufacturing technologies for realizing the metallic and non-metallic objects.

The special emphasis is given to link computer interface with the digital manufacturing process and their demonstration using commercially available software. The modules cover almost all the direction of additive manufacturing technologies, and it is blended with fundamental development to the recent technologies.

The audience will be able to develop a fundamental understanding of different perspectives and recent development in this field through the lectures, skill development through demonstration, and reinforce their knowledge by solving assignments.

Advantages of additive manufacturing (AM)

- The Cost of Entry Continues to fall. ...
- Save on Material Waste and Energy. ...
- Prototyping Costs Much Less. ...
- Small Production Runs Often Prove Faster and Less Expensive. ...
- Don't Need as Much On-Hand Inventory. ...
- It's Easier to Recreate and Optimize Legacy Parts.
- Easy to Change or Revise Versions of a Product
- Training Programs Are Becoming Readily Available at All Levels

Disadvantages of additive manufacturing (AM)

- Limited Materials
- Restricted Build Size
- Post Processing
- Large Volumes
- Reduction in Manufacturing Jobs
- Design Inaccuracies
- Copyright Issues

Classification of additive manufacturing process

7 types of Additive manufacturing

- photopolymerisation,
- Material Extrusion,
- Material Jetting,
- Binder Jetting,
- Powder bed fusion,
- Direct energy deposition
- Sheet lamination.

photopolymerization

This process uses a technique called Photopolymerization in which radiation curable resins or photopolymers are used to create three-dimensional objects by selectively exposing them to ultraviolet light. When exposed these materials undergo a chemical reaction and become solid.

There are three main types under this category – Stereo lithography, Digital Light Processing and Continuous Digital Light Processing.

Powder bed fusion

Powder bed fusion processes especially the selective laser sintering is one of the early industrial additive manufacturing techniques. This method uses a laser or electron beam to melt the powdered material and fuse them together to create a solid object.

Direct metal laser sintering, Selective laser sintering, Multi Jet Fusion, Electron beam melting, Selective laser melting and Selective heat sintering are the main types of powder bed fusion.

Binder jetting

Binder jetting uses a binding agent usually in liquid form and selectively deposits onto powdered material. The print head and a powder spreader deposit alternating layers of bonding agent and build material to form a 3d object.

Material extrusion

Material extrusion was originally developed and patent by S. Scott Crump under Fused Deposition Modelling (FDM) in the 1980s. In this additive manufacturing technique, the continuous filament of thermoplastic is fed through a heated nozzle, before deposited layer by layer onto the build platform to create the object.

Directed energy deposition (DED)

Directed energy deposition technology uses focused thermal energy to melt and fuse the material together as they are deposited to create a 3d object. These are very similar to welding process but very finely detailed.

Material jetting

This additive manufacturing technique is very similar to common inkjet printers where the material droplets are deposited layer by layer selectively to create a three-dimensional object. Once a layer is complete, it's cured by ultraviolet light.

Sheet lamination

Sheet lamination technology is an umbrella term for the Ultrasonic Additive Manufacturing, Selective Deposition Lamination and Laminated Object Manufacturing. All these technologies use sheets of material to create 3D objects by stacking them and laminating them using either adhesive or ultrasonic welding. Once the object is built the unwanted areas of the sections are removed layer by layer.

Fundamental automated process

Automation is the use of electronics and computer-controlled devices to assume control of processes. The aim of automation is to boost efficiency and reliability. In most cases, however, automation replaces labor. Automation encompasses many key elements, systems, and job functions in virtually all industries.

Types of automation

- (1) Fixed automation,
- (2) Programmable automation,
- (3) Flexible automation.

DIFFERENCE BETWEEN AM AND CNC



Parameter	AM machining	CNC machining
Material	AM includes development of polymeric material, waxes and paper laminates.	CNC used for machining soft materials or medium density fiber board, machinable foams and machinable waxes etc.
Speed	Higher, takes few hours to make part.	Lower, takes weeks to develop same part.
Complexity	Complex operation	Easy operation
Efficiency	Higher	Lower
Accuracy	More accurate	Comparatively less
Programming	In AM machine the part won't be built properly if in correct programming is done	In correct programming can badly damage the machine and may even be safety risk.
Process	It is an additive process.	It is subtractive process.

Design for additive manufacturing

Design for Additive Manufacturing (DfAM) is the art, science and skill to design for manufacturability using 3D printers. Different from traditional manufacturing, this additive design process empowers engineers to create more intricate shapes and production parts while reducing weight and material consumption.

Application of additive manufacturing in aerospace

The aerospace industry has been using additive manufacturing (AM) for many applications. From aircraft and helicopter parts to engines and turbines, 3D technologies save time and money to create stronger, more efficient components. AM has improved part performance, reduced weight, and has helped to remove design and production constraints.

Aerospace industry is constantly demanding lightweight components with high strength to weight ratio to improve fuel efficiency, reduce emissions and respond to safety and reliability requirements. AM allows the fabrication of parts with virtually any shape.

Application of additive manufacturing in automotive industry

This technology is also used for testing, manufacturing, and assembling automotive parts and components with higher efficiency, optimization, and cost-efficiency. Additive manufacturing technology is not new to the automotive industry, considering the past couple of years with immense activities in this field.

Additive manufacturing allows automotive companies to customize car assembly tools by improving its functionality and reducing its weight at a lower cost than traditional manufactured tools. There are even cases where completely new tools are developed for specific, customized designs.

Application of additive manufacturing in jewelry industry

Additive fabrication enables the fabrication of new products and geometries reducing manufacturing time, energy and labor costs. ... A computational application for jewellery design is also presented to help manufactures and customers to fabricate novel jewellery pieces.

The jewellery industry still works essentially on traditional fabrication methods to much time consuming and in some cases lacking efficiency compared to the quality of the end product. The inclusion of new technologies can be a solution to overcome these issues.

Additive fabrication enables the fabrication of new products and geometries reducing manufacturing time, energy and labor costs.

Application of additive manufacturing in art and architecture

Architects and designers now have access to larger and more capable additive manufacturing equipment to explore how to translate their virtual 3D BIM models to an actual 3D printed product that can be used in the construction of buildings. Below are some examples of how additive manufacturing of a variety of materials has been used in construction. This capacity is possible primarily because of advances in concrete fabrication technologies.

Application of additive manufacturing in rp medical and bioengineering

Rapid prototyping technologies have introduced a new approach for surgical planning and simulation. The technologies enable one to create anatomical objects in a three-dimensional view giving the surgeon a realistic representation of the target organ in the body.

Other important applications of the prototyping technology are in the development of medical devices and instrumentations. Medical instruments that have been upgraded using the 3D technology include surgical fasteners, scalpels, retractors, display systems, among many others.

Most hearing aid devices are designed using the stereolithography or the selective laser sintering. Other areas that are adapting the rapid prototyping technology is the replacement of teeth.

webs based rapid prototyping system

Rapid prototyping and manufacturing (RP&M) technique has shown a high potential to reduce the cycle and cost of product development, and has been considered as one of crucial enabling tools in digital manufacturing to effectively aid rapid product development. Manufacturing industry is evolving toward digitalization, network and globalization. The Internet, incorporating computers and multimedia, has provided tremendous potential for remote integration and collaboration in business and manufacturing applications. RP&M technique using the Internet can further enhance the design and manufacturing productivity, speed, and economy, as well as share the RP machines.

A web-based rapid prototyping and manufacturing (RP&M) system offers a collaborative production environment among users and RP&M providers to implement the remote service and manufacturing for rapid prototyping, to enhance the availability of RP&M facilities, and to improve the capability of rapid product development for various small and medium sized enterprises.

3.6 concept of flexible manufacturing system (FMS)

The Flexible manufacturing systems (FMS) is made up of hardware and software elements. . FMS is actually an automated set of numerically controlled machine tools and material handling systems, capable of performing a wide range manufacturing operations with quick tooling and instruction changeovers.

A flexible manufacturing system (FMS) can improve efficiency and thus lower a company's production cost. Flexible manufacturing also can be a key component of a make-to-order strategy that allows customers to customize the products they want.

Concurrent Engineering (CE)

Concurrent Engineering (CE) is the consideration of the factors associated with the life-cycle of a product during the design phase. CE is important because it is at the design stage that such aspects as product quality and cost are specified. In the case of flexibly automated production CE is especially important since some designs may be difficult or impossible to manufacture using automated equipment.

Production tools like capstan and turret lathe

Capstan and Turret lathes are production lathes use for assembling of a huge number of comparable workings in the slightest feasible time. These lathes are progression above center lathes. Machining of a job on a center lathe takes extensive time, which is avoided on a turret lathe with the assimilation of services for moving eight or extra tools. Characteristic features of these machines are capstan or turret head mount on the bed. Tool can attach to every face of turret head. On capstan lathe drive to the turret is given as of a support slide clamped to the top of the bed. Turret is changeable so that its distance as of machine nose can be diverse. Turret of turret lathe is mounting on saddle slides straight on a bed in a similar way as a lathe saddle. It is the difference of form of carrying turret which distinguishes capstan lathe as of turret lathe. In all other respect these machines are comparable.

The semiautomatic lathes, capstan lathe, and turret lathe are very similar in construction, operation, and application.

- Capstan lathes are mainly used for bar work, whereas turret lathes are applicable for large work in the form of castings and forgings.
- capstan and turret lathe is used to manufacture any number of identical workpieces in less time. These lathes are the development of engine lathes.
- The turret head is mounted on the ram fitted with turret slides longitudinally on the saddle.
- Turret head has a hexagonal block having six faces with a bore for mounting six or more than six tools at a time.
- The threaded hole on these faces is used to hold the tools.
- In the case of a Capstan Lathe, the hexagonal turret is mounted on a short slide or ram which again fitted with a saddle.
- The saddle can be move accordingly throughout the bed ways and can be fixed to the bed if necessary.
- It is specially used for bar type jobs.
- But in the case of Turret Lathe, the hexagonal turret directly mounted on the saddle. The saddle can be move through the bed ways.
- Turret lathe is generally used for chucking type work.
- The workpiece is held in collet or chucks which are actuated hydraulically or pneumatically.
- All the needed tools are held in the respective holes on the turret head.
- According to the sequence of operation, the tool is moved with the help of a turret head.
- Drilling, boring, turning, reaming, threading tools are mounted on the turret head.
- Forming, chamfering, knurling tools are mounted on the front end of the turret.
- The Parting tool is mounted in an inverted position on the rear end of the turret.
- After completing each operation the turret head is moved back to its initial position which indexes the tools automatically.

Capstan Lathe Vs Turret Lathe

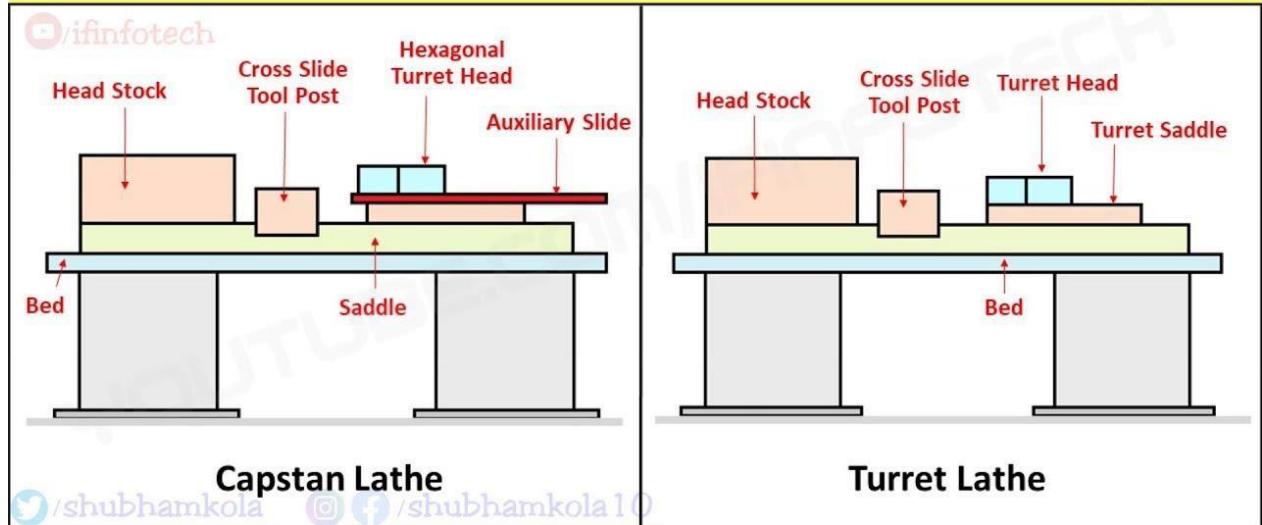

-THE END-

POSSIBLE QUESTIONS

Short question

4. What is AM?
5. What is the need of AM?
6. Define automation
7. What is FMS?
8. .Define rapid prototype.

Long questions

1. What are the fundamental AM?
2. Advantage and disadvantage of AM
3. Difference between CNC and AM.
4. Explain the production tools of turret and capstan lathe.
5. Explain the applications of designing AM.
- 6.

CHAPTER NUMBER -04

SPECIAL PURPOSE MACHINE (SPM)

concepts

SPMs or Special Purpose Machines offer tremendous scope for high volume production at low investment and at low cost of production when compared to CNC machines. SPM, Special Purpose Machines is a high productivity machine, with specially designed tooling and fixture, dedicated for mass producing the same component day in and day out.

Combination of limit switches, sensors, logic controls, automatic job clamping etc is the essence of a SPM. A well conceived Special Purpose Machine finds ways and means to utilize the man and machine to the optimum. We offer low cost dedicated SPMs for mass production of small components of 2 & 4 wheelers, tractors, trucks, engines etc. Typical components are rear wheel flange, shifter cam, shifter fork, clutch sleeve etc. our spms are suitable for mass production of components which involve operations like turning, boring, facing, drilling, reaming, tapping, chamfering etc.

Special-purpose machine tools are designed to perform special machining operations, usually for production purposes. Examples include gear-cutting and gear-grinding machines, broaching machines, lapping and honing machines, and boring machines.

. Elements of Special Purpose Machine

The special purpose machine consists of two major elements.

Piercing tool. (Punch and Die)

- Hydro pneumatic system - cylinders and controls to develop force to pierce holes.

Productivity improvement by spm

The Special Purpose Machines (SPM) is designed to operate continuously for 24 hours a day, with minimum supervision. The Special Purpose Machines are generally Product Specific & they are required to be Designed & Developed for specific requirement. Sometimes it may be possible to cater to the Jobs having similar features but differing in dimensions by change tooling concept.

Special Purpose Machines (SPM) is either Cam Operated Machine or they use hydraulics or pneumatics as actuating elements or combination of all the three of them. Many times Programmable Logic Controller is used in conjunction with Positional

Sensors & Transducers, to give commands to the actuating elements. Sometimes different motors like Stepper Motor & Servo Motors are used as actuating elements. The productivity achieved after all these efforts is very high. Productivity of 3 to 10 times is achievable. However to fetch the fruits of these highly specialized machines the precondition is that the input to the automatic machine must have strict quality control.

Principle of SPM design

Automation and technological advancements have drastically changed the manufacturing industry. One such aspect is Special Purpose Machine (SPM) design. As SPM is not created on standard manufacturing programs, immaculate design is crucial to ensure product performance and safety.

Designs for a wide array of applications, which include:

- Specialized industrial machines
- Processing and packaging equipment
- Welding automation
- Gantry pick and place systems
- Automated test equipment
- Tooling systems for casting and sheet metal
- Specialized manufacturing equipment
- Articulating arms
- Part transfer chutes
- Rapid prototyping

Designing special purpose machines is same as designing any machines. You should have a good grasp of 4 pillars of machine design:

1. Theory: Statics, Kinematics, Dynamics, Material science, Mathematics
2. Good knowledge of standard machine element: bearings, screws, shaft collars,...
3. Knowledge of machine drawings, how to produce documentation, projections, tolerances, GD and T...
4. Good skills with preferred CAD software It depends on your manner of approach.

Special purpose machine design services involve:

- Conceptual design

- Reverse engineering
- Detailed drawing
- Legacy CAD conversions

-THE END-

POSSIBLE QUESTIONS

Short question

1. Define SPM?
- .2. What are the general elements of SPM

Long questions

1. Explain principle of SPM design.

CHAPTER NUMBER -05

MAINTENANCE OF MACHINE TOOLS

51. Types of Maintenance

Repair cycle analysis

Repair cycle refers to the stages through which a repairable item passes from the time of its removal or replacement until it is reinstalled or placed in stock in a serviceable condition.

Repair cycle consists of functioning parts in use by equipment operators, and the entire sequence of suppliers or repair providers that replenish functional part inventories, either by production or repair, when they have failed.

The manager should distinguish the state or condition of items in stock to properly manage repairable components. S/he must know if a component is in RFI or request for information condition, being repaired, or requiring repair. The code of supply condition is assigned to classifying the components in terms of their readiness for use and issue. As materials or parts move through the repair cycle, their code of condition changes. The most recent code of condition is used for recording the status of the component or material.

Repair complexity in maintenance

Maintenance Repair and Operations activities in relation to production equipment include actions like routine maintenance work, emergency maintenance, spare parts inventory control, purchasing condition monitoring equipment, and vendor management.

The challenge for maintenance, repair, & overhaul (MRO) providers is to be able to cope with the unpredictability and complexity of customer demand. The exact scope and specific requirements of each job – including the necessary materials, spare parts, equipment, and employees – are typically not known until a given machine is taken apart and the problem diagnosed.

To ensure ongoing productivity and profitability, MRO providers must be able to operate with great efficiency and flexibility to deliver fast, reliable, and customized service for customers, and effectively allocate resources and inventory to reduce operational costs.

Maintenance manual and housekeeping

A maintenance manual is a technical communication document intended to give recommendations and information necessary to maintain the system effectively.

It is a comprehensive document that provides all the details necessary about a physical plant as well as individual pieces of equipment to help the maintenance staff keep everything running smoothly.

A maintenance manual is an essential part of a regular maintenance program. The manual should include a log book and **housekeeping** plan for the day-to-day care and management of a heritage place. Make a maintenance manual part of the conservation plan for a heritage place to provide for its ongoing care.

Maintenance record

Maintenance record, as name suggests, is a document that includes information regarding each repair and maintenance work that is done on asset or equipment. In simple words, it keeps tracks of assets failures and repairs. It is one of best way to maintain health and safety management.

Advantages of keeping Maintenance Record

There are several benefits of keeping maintenance record. Some of them are given below:

- Prevent Expensive Repairs
- Increases Safety
- Replacing Equipment
- Reduce Labor Workload
- Manage Each Machine

Introduction to total productive maintenance (TPM)

Total Productive Maintenance (TPM) started as a method of physical asset management focused on maintaining and improving manufacturing machinery, in order to reduce the operating cost to an organization.

Total productive maintenance (TPM) is the process of using machines, equipment, employees and supporting processes to maintain and improve the integrity of production and the quality of systems.

TPM was introduced to achieve the following objectives. The important ones are listed below.

- Avoid wastage in a quickly changing economic environment.
- Producing goods without reducing product quality.
- Reduce cost.
- Produce a low batch quantity at the earliest possible time.
- Goods sent to the customers must be non defective.

Total quality management (TQM) and total productive maintenance (TPM) are considered as the key operational activities of the quality management system. In order for TPM to be effective, the full support of the total workforce is required. This should result in accomplishing the goal of TPM: "Enhance the volume of the production, employee morals, and job satisfaction"

The main objective of TPM is to increase the Overall Equipment Effectiveness (OEE) of plant equipment. TPM addresses the causes for accelerated deterioration and production losses while creating the correct environment between operators and equipment to create ownership.

The **eight** pillars of TPM are mostly focused on proactive and preventive techniques for improving equipment reliability:

1. Autonomous Maintenance - Operators who use all of their senses to help identify causes for losses
2. Focused Improvement - Scientific approach to problem solving to eliminate losses from the factory
3. Planned Maintenance - Professional maintenance activities performed by trained mechanics and engineers
4. Quality management - Scientific and statistical approach to identifying defects and eliminating the cause of them
5. Early/equipment management - Scientific introduction of equipment and design concepts that eliminate losses and make it easier to make defect free production efficiently.
6. Education and Training - Support to continuous improvement of knowledge of all workers and management
7. Administrative & office TPM - Using TPM tools to improve all the support aspects of a manufacturing plant including production scheduling, materials management and information flow, As well as increasing moral of individuals and offering awards to well deserving employees for increasing their morals.
8. Safety Health Environmental conditions

-THE END-

POSSIBLE QUESTIONS

Short question

1. What are the types of maintenance?

Long questions

SHORT NOTE ON

- Repair cycle analysis.
- Repair complexity
- Maintenance record
- TPM.