

GOVT. POLYTECHNIC , BHADRAK

# Automobile Engg. & Hybrid Vehicles (Th- 02)

(As per the 2020-21 syllabus of the SCTE&VT,  
Bhubaneswar, Odisha)



Sixth Semester

Mechanical Engg.

**Prepared By: *Er SUMANTA BISWAL.***

## AUTOMOBILE ENGINEERING AND HYBRID VEHICLES (Th-02)

Chapter No.	Topics	Periods as per Syllabus	Required period	Expected Marks	
01	Introduction & Transmission System	12	14	07	20
02	Braking system	05	06	06	10
03	Ignition & Suspension System	10	12	07	15
04	Cooling and Lubrication	08	09		15
05	Fuel system	10	12		15
06	Hybrid and Electric Vehicles	15	17		20
<b>TOTAL</b>		<b>60</b>	<b>70</b>	<b>20</b>	<b>80</b>

## **CHAPTER -01**

### **INTRODUCTION AND TRANSMISSION SYSTEM**

Automobile is a branch of engineering in which we study all about the automobiles and have practice to propel them .the word automotive engineering is also used having the same meaning .

An automobile is a self propelled vehicle which is used for the transportation of passengers and goods upon the ground . a vehicle is a machine which is used for the transportation of passengers and goods upon the ground . a self propelled vehicle is that in which power required for the propulsion is produced from within

#### **CLASSIFICATION OF AUTOMOBILE**

The automobiles are classified on the following basis

##### 1.purpose

- i.Passenger vehicle- car, jeep, bus.
- ii.Good vehicle -truck

##### 2. capacity

- i.light motor vehicles – car ,motor cycle , scooter.
- ii.heavy motor vehicles -bus , coach, tractor

##### 3. fuel used

- i.Petrol vehicle – car,jeep, motor cycle, scooter.
- ii.Diesel vehicle- truck , bus , tractor, bulldozer
- iii.Electric cab- battery truck, fork lift

iv. Steam cattiages – steam road rollers

v. Gas vehicles -cng vehicles

4.no. of wheels:

i. Two wheeler- mopeds, scooter, motor cycles

ii. Three wheeler – cars, jeeps, bus, tractors

iii. Six wheeler -truck, tanker , gun carriage vehicles

5. drive of the vehicles:-

i. Single wheel drive vehicle.

ii. Two wheel drive vehicle.

iii. Four wheel drive vehicle.

iv. Six wheel vehicle.

Automobile chassis.

A complete vehicle with out body is called chassis. It consist of major unit to propel the vehicle ,direct its motion , stop it and allow it to run smoothly over uneven surface.

The chassis include the following components

1. Frame

2. Front suspension

3. Steering mechanism

4. Radiator

5. Engine, clutch, gear box

6. Propeller shaft

7. Rear spring

8. Road wheels

9. Differential, halfshaft, universal joint

10. Brakes and braking system

11. Storage battery

12. Silencer

13. Shock absorber, fuel tank, petrol and hydraulic pipe cables and some means of mounting these components

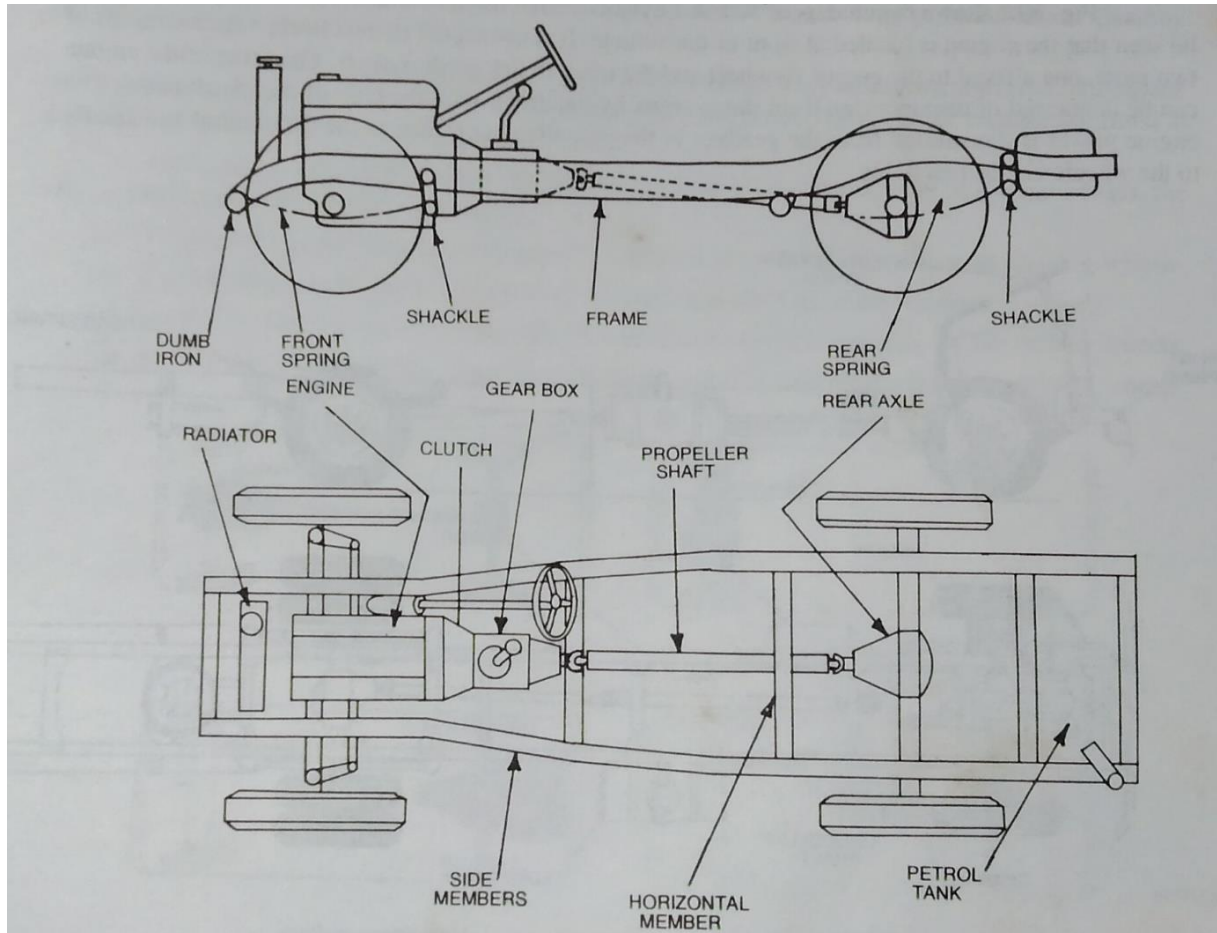

### **CLUTCH AND ITS FUNCTION**

Clutch is a device used in the transmission system of a motor vehicle to engage and disengage the engine to the transmission. Thus, the clutch is located between the engine and the transmission. When the clutch is engaged, the power flows from the engine to the rear wheels through the transmission system and the vehicle moves. When the clutch is disengaged, the power is not transmitted to the rear wheels and the

vehicle stops while the engine is still running. The clutch is disengaged when starting the engine, when shifting the gears, when stopping the vehicle and when idling the engine. The clutch is engaged only when the vehicle is to move and is kept engaged when the vehicle is moving. The clutch also permits the gradual taking up of the load. When properly operated, it prevents jerky motion of the vehicle and thus avoids putting undue strain on the remaining parts of the power transmission system.

The clutches used in motor vehicle are almost very similar in construction and operation. There are some differences in the details of the linkage as well as in the pressure plate assemblies. In addition, some clutches for heavy duty applications have two friction plates and an intermediate pressure plate. Some clutches are operated by hydraulic means. The dry single plate type of friction clutch is used almost exclusively in American passenger cars. Where the dry plate clutch operates dry--without using oil, the wet plate clutch operates in a bath of oil. Most designs of the clutches use number of coil springs but some use a diaphragm or conical type spring. The type of friction materials also varies in the clutches of different passenger cars.

Different types of clutches are as follows:

1. Friction clutch :

(a) Single plate clutch. (b) Multiplate clutch : (1)

Wet

(ii) Dry. (c) Cone clutch. (1) External (ii) Internal

2. Centrifugal clutch.

3. Semi-centrifugal clutch.

4. conical spring clutch.

a. tapered finger type .

b. crown spring type.

5. Positive clutch - Dog and spline clutch

6. Hydraulic clutch.

7. Electro-magnetic clutch.

8. Vacuum clutch

9. Over running clutch or free-wheel unit.

### **SINGLE CLUTCH PLATE**

It is the most common type of clutch used in motor vehicles. Basically, it consists of only one clutch plate, mounted on the splines of the clutch shaft, as shown in

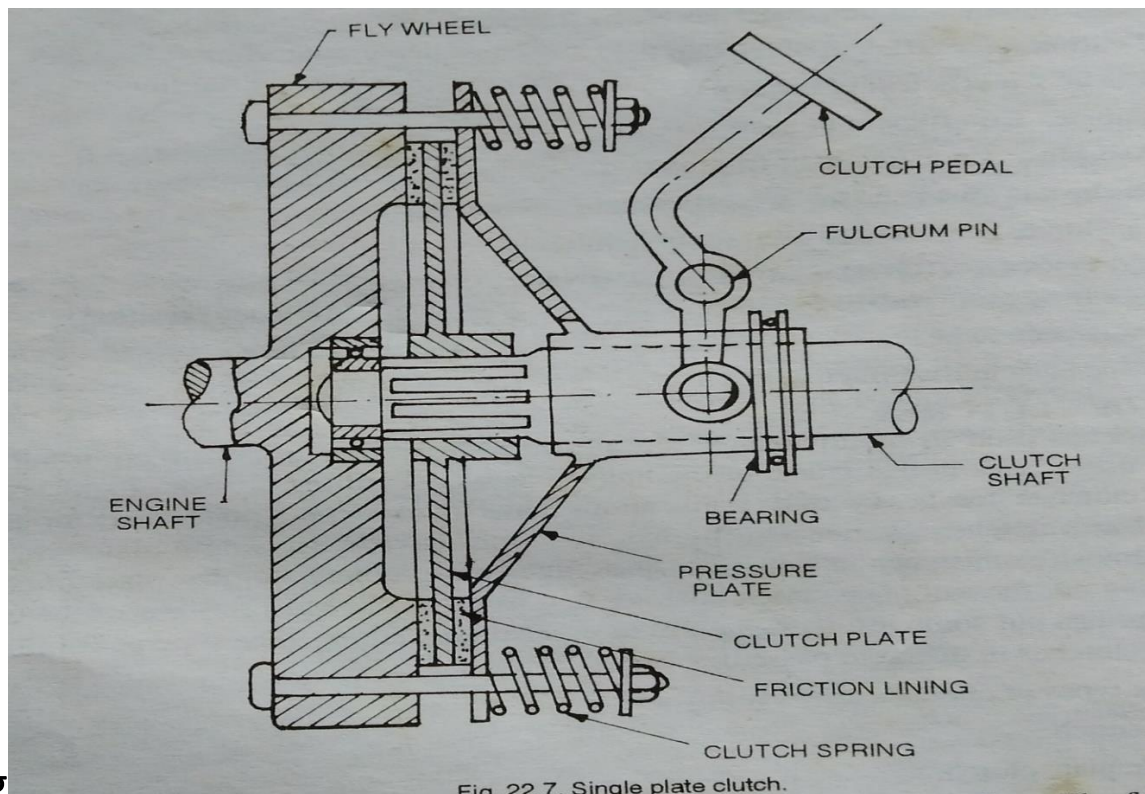

fig

Fig. 22.7. Single plate clutch.

The flywheel is mounted on the engine crankshaft and rotates with it. The pressure plate is bolted to the flywheel through clutch springs, and is free to slide on the clutch shaft when the clutch pedal is operated. When the clutch is engaged, the clutch plate is gripped between the flywheel and the pressure plate. The friction linings are on both the sides of the clutch plate. As the flywheel revolves, the clutch plate revolves with the flywheel. As the clutch plate revolves, the clutch shaft also revolves with the flywheel. As the clutch plate revolves, the clutch shaft also revolves, and the clutch shaft is connected to the transmission to the crankshaft.

When the clutch pedal is pressed, the pressure plate moves back against the force of the spring and the clutch plate becomes free between the flywheel and the pressure plate. Thus the flywheel remains rotating as long as the



engine is running and the clutch pedal is pressed, the clutch is said to be disengaged otherwise it remains engaged due to spring forces.

### **MULTIPLATE CLUTCH**

Multiplate clutch consists of a number of clutch plates, instead of only one clutch plate as in the case of single plate clutch. As the number of clutch plates are increased, the friction surface also increases. The increased number of friction surfaces obviously increases the capacity of the clutch to transmit torque. The plates are alternately fitted to the engine shaft and gear box shaft. They are firmly pressed by strong coil springs and assembled in a drum. Each of the alternate plate slides in grooves on the flywheel and the other slides on splines on the pressure plate. Thus, each alternate plate has inner and outer splines.

The multiplate clutch works in the same way as the single plate clutch, by operating the clutch pedal. The multiplate clutches are used in heavy commercial vehicles, racing cars and motor cycles for transmitting high torque.

The multiplate clutches may be dry or wet. When the clutch operates in an oil bath, it is called a wet clutch. When the clutch is operated dry it is called dry clutch.

The wet clutch are generally used in conjunction with or as a part of the automatic transmission.

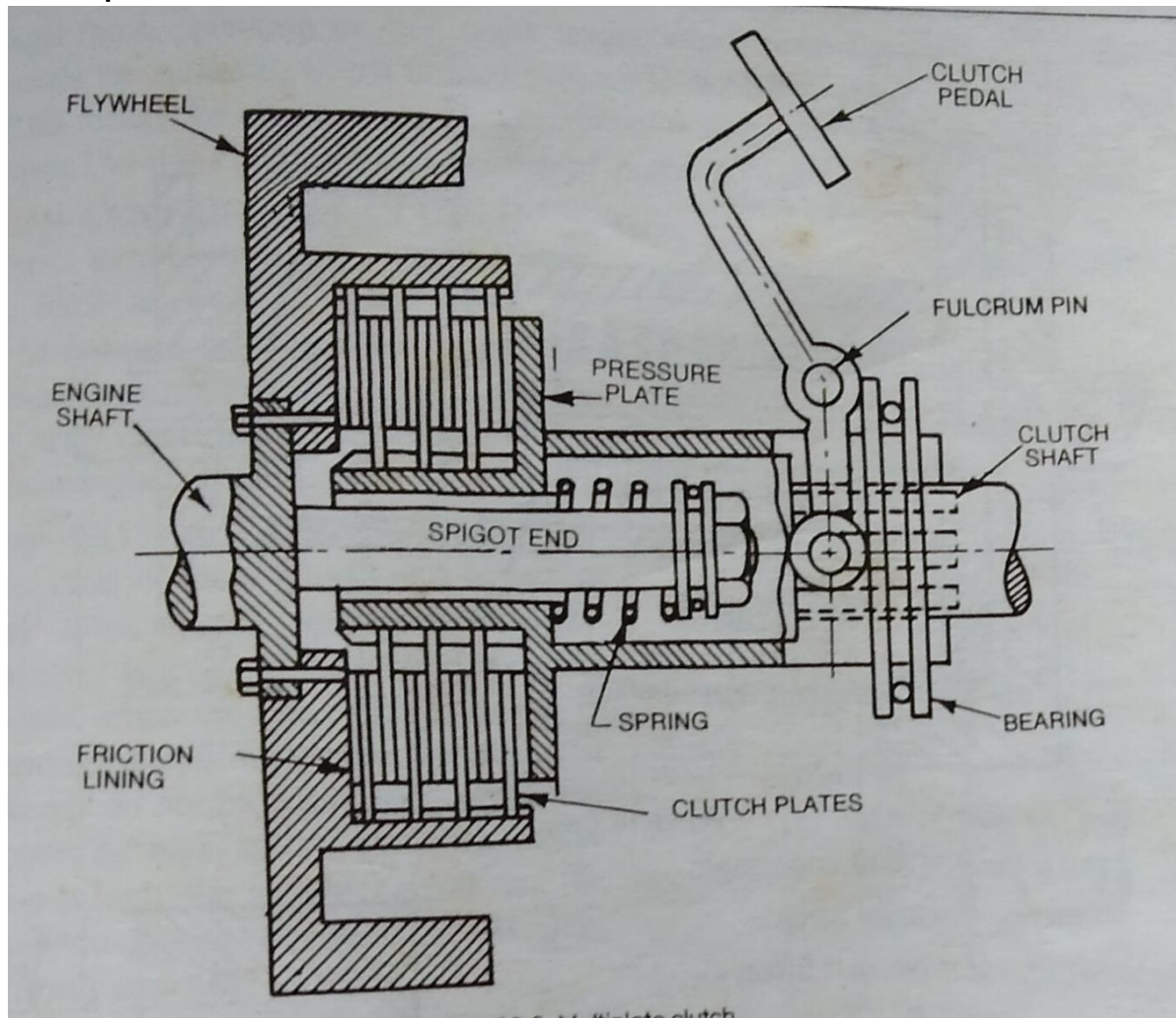

## GEARBOX OR TRANSMISSION

### INTRODUCTION

Next to the clutch is the transmission in the transmission system of a motor vehicle. The word "transmission" is used for a device that is located between the clutch and the propeller shaft. It may be a gear box, a torque convertor, overdrive, fluid drive or

hydraulic drive. In this chapter we will describe box in details, the other devices will be described in the next chapter.

### PURPOSE OF TRANSMISSION

The purpose of the transmission is to provide high torque at the time of starting, hill climbing, accelerating and pulling a load. When a vehicle is starting from rest, hill climbing, accelerating and meeting other resistances, high torque (tractive effort) is required at the driving wheels. Hence a device must be provided to permit the engine crankshaft to revolve a relatively high speed, while the wheels turn at slower speeds. This is obtained by a set of gears called a transmission or gear set. The gear set is enclosed in a metal box called a gear box. The vehicle speed is also changed with the help of the transmission keeping the engine speed same with certain limit.

### Four speed Gear Box

Shows the layout of a 4- speed gear box using synchromesh system in all the four forward speeds. Readers will note from the figure that the clutch shaft drives the countershaft drive gear through main drive gear. The first, second and third speed gears on the main shaft are in constant mesh with their corresponding gears on the countershaft. The reverse idler gear and the reverse sliding gear are not in mesh.

In this position, the gear box is in neutral since no power is transmitting to the main shaft.

First gear

Fig.

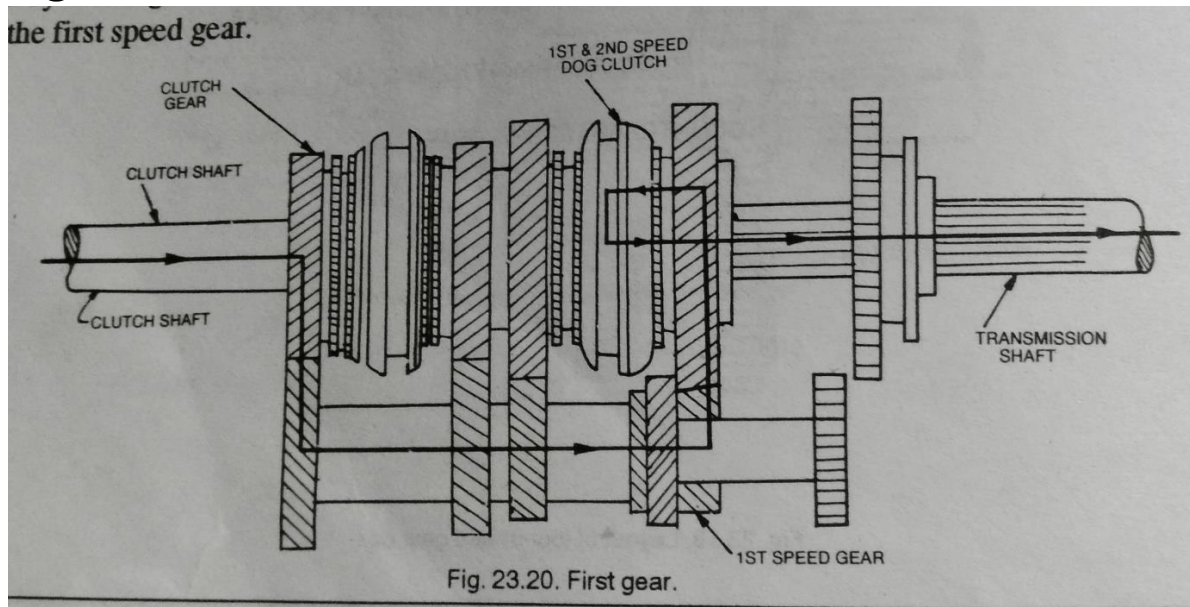

shows the layout of gears transmitting power in first gear, This gear is obtained by shifting the dog clutch to the right thus engaging its internal teeth with the external dog

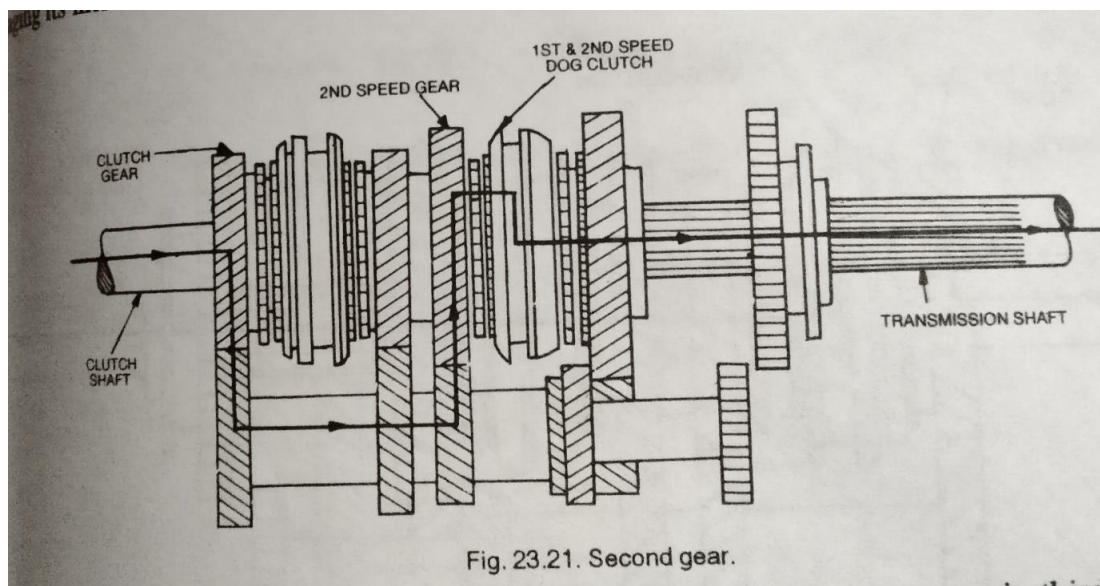

teeth of the first speed gear.

**Second gear.**

Fig. shows the layout of gears transmitting power in second gear. To obtain this gear, first the 1-2 speed dog clutch is brought to neutral and then moved to the left thereby engaging its internal teeth with the external dog teeth of the second speed gear.

Third gear.

Fig.

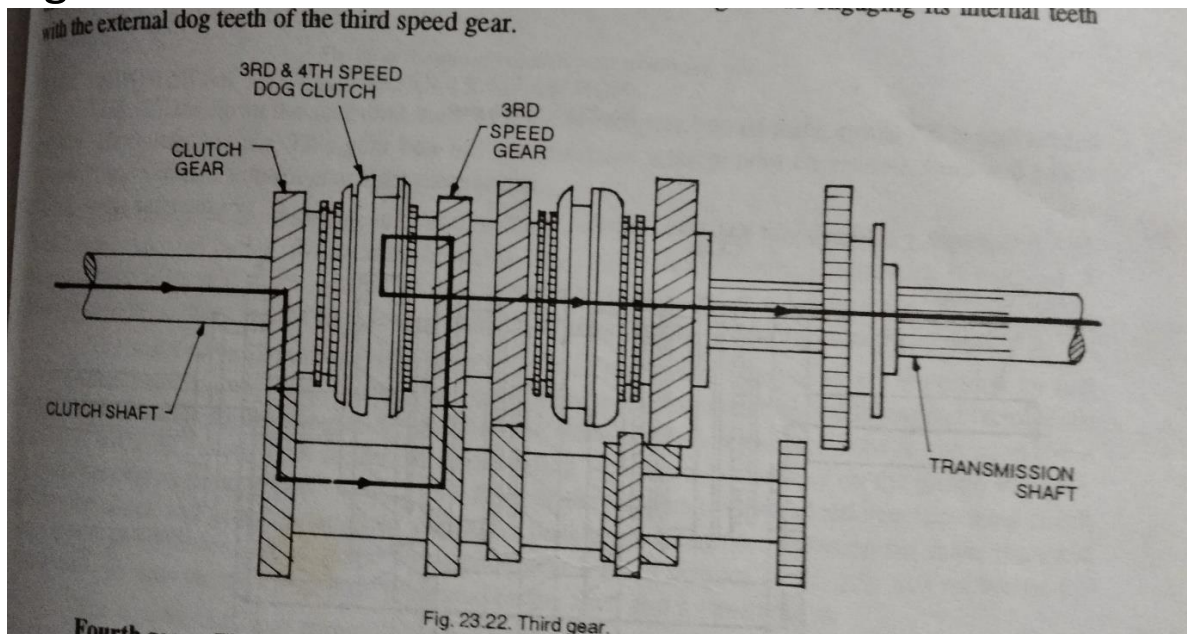

shows the layout of gears transmitting power third gear. In order to obtain this gear, first 1-2 speed dog clutch is shifted out of mesh from second gear and brought to neutral position. The 3-4 speed dog clutch is then moved to the right thus engaging its internal teeth with the external dog teeth of the third speed gear.

## Fourth gear.

Fig.

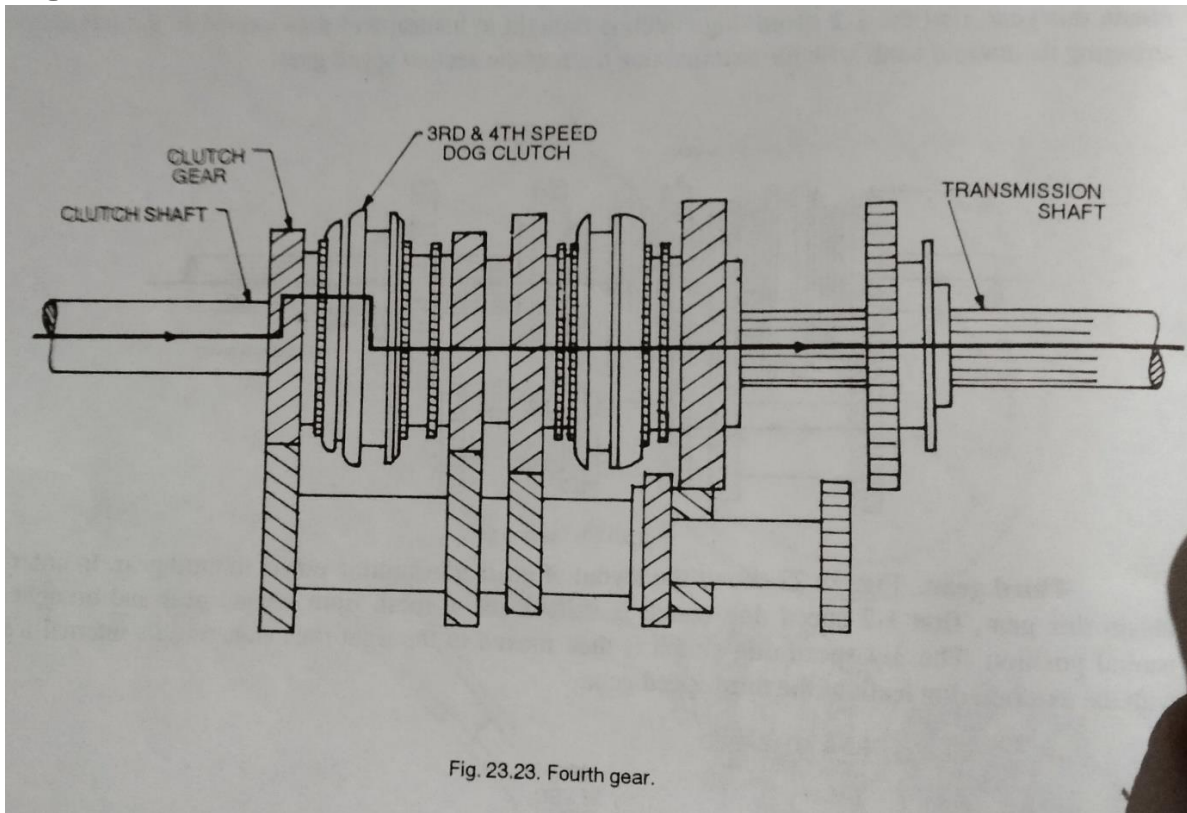

shows the layout of gears transmitting power in fourth gear. In order to obtain this gear, the 3-4 dog clutch is first shifted to neutral position and then shifted to the left thus engaging its internal teeth with the external dog teeth of main drive gear.

Reverse gear.

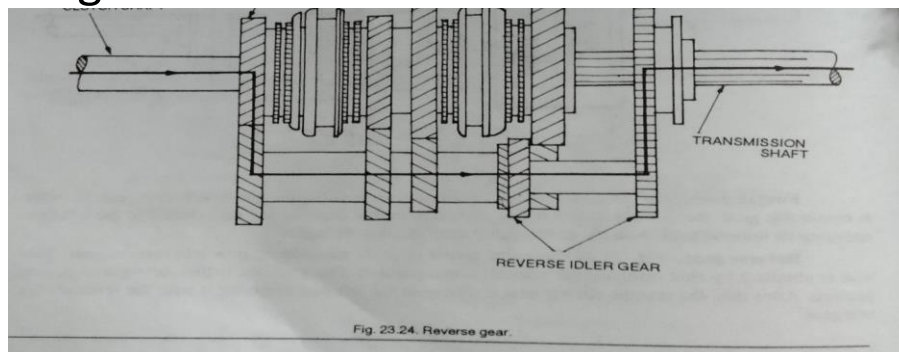

Fig

shows

the layout of gears transmitting power in reverse gear.

This gear is obtained by first bringing the vehicle to rest position. The gear box is then brought to neutral position. After this, the reverse sliding gear is moved to the left thus engaging it with the reverse idler rear gear.

### **GEAR SHIFTING MECHANISM**

The transmission case is a two-piece construction, consisting of the upper case and lower case. The lower case has the three fork shifting mechanism built in it. The upper case house the reverse shaft.

**Low speed drive.** The low driven gear on the countershaft is free from this shaft and merely rotates around it, as driven from the low -drive gear of the input shaft. Shifting of the lever into 'low' causes the low -speed gear shifter fork to push the low -speed synchronizer towards the low driven gear and, through the dog teeth, mesh it with the gear, thus coupling the gear to the input shaft. In this condition, the drive is transmitted through the low drive gear on the input shaft and the low-driven gear on the countershaft to the gear of the final differential.

**Second speed drive.** Shifting the lever into 'second' causes the same low speed gear shifter fork to push the low-speed synchronizer to the other direction i.e., towards the second driven gear, and mesh it with this gear thereby coupling the gear to the input shaft.

**Third speed drive.** Shifting the lever into 'third' actuates high speed shifter fork to engage the high-speed synchronizer with third driven gear on the countershaft. This gear, like the low and second driven gears, is free on the shaft and merely spins as driven by the third drive gear of input shaft when the gear shift lever is at any other position

In this condition, the drive is transmitted through the third -drive gear on the input shaft and the third -drive gear on the countershaft to the final gear of the differential.

**Top speed drive.** Shifting the lever into 'top' causes the high-speed shifter fork, which is also used for the third speed, to mesh the top gear with the high-speed synchronizer on the countershaft.

In this condition, the drive is transmitted through the top drive gear on the input shaft and top driven gear on the countershaft to the final gear of the differential.

**Reverse drive.** Shifting the lever into reverse causes the reverse gear shifter fork to mesh the reverse idler gear with the reverse gear on the input shaft and the low speed synchronizer sleeve on the countershaft.



In this condition, the drive is transmitted through the reverse gear on the input shaft, reverse idler gear and low-speed synchronizer on the countershaft to the final gear of the differential.

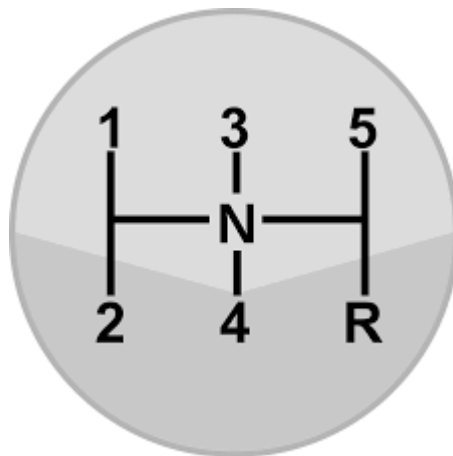

Gear shift lever position

### **PROPELLER SHAFT**

The propeller shaft is driving shaft that connects the transmission to the differential. The output shaft or main shaft from the transmission and pinion shaft extending from the differential unit are connected to the propeller shaft and the universal joints. A sliding joint is also used between the propeller shaft and the universal joint near the gear box. The rotary motion of the transmission main shaft is carried out through the propeller shaft to the differential, causing, the rear wheels to rotate. The propeller shaft has to withstand the torsional stresses of the transmitting torque, and

yet it must be light and well balanced so that vibrations and whip will not occur at high speeds. For these reasons, it is made of a strong steel tube. Solid propeller shafts are also used. The propeller shaft may be exposed to the atmosphere or protected by an outer tube. Some applications include bearing at or near the propeller shaft centre to support the shaft. In some applications, the propeller shaft is in two sections, supported by a center bearing and coupled together by universal joint.

It is to be noted that the transmission main shaft and the differential pinion shaft are not in one horizontal level. The rear axle housing with differential is attached to the frame by springs, therefore, the distance between the gear box and the differential changes due to road irregularities. This also changes the angle of drive. In order that the propeller shaft must take care of these two changes it is provided with one or more universal joints to permit variations in the angle of drive. Also, it must be provided with a sliding joint that permits the effective length of the propeller shaft to change.

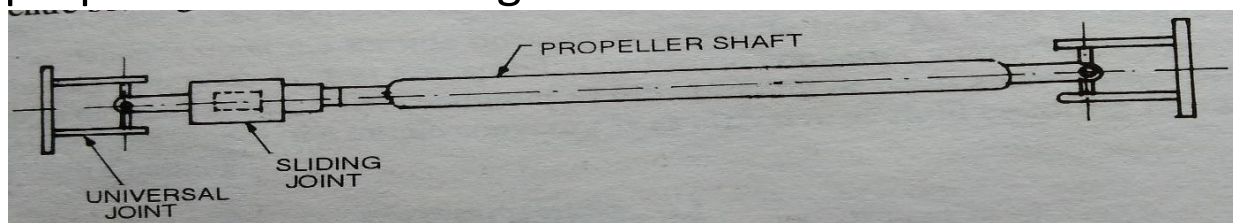

## **-DIFFERENTIAL**

If a car travels in a straight line, the two rear wheels turn on the road exactly at the same speed. There is no relative movement between the two rear wheels. The propeller shaft may be geared rigidly, in this case, with the rear axle to rotate the rear wheels together. But when the car takes a turn, the outer wheel travels on a longer radius than the inner wheel. The outer wheel turns faster than the inner wheel, that is, there is a relative movement between the two rear wheels. If the two rear wheels are rigidly fixed to a rear axle the inner wheel will slip which will cause rapid tyre wear, steering difficulties and poor road holding.

Therefore, there must be some devices to provide relative movement to the two rear wheels when the car is taking a turn. The differential serves this purpose.

Differential is a part of the inner axle housing assembly, which includes the differential, rear axles, wheels and bearings. The differential consists of a system of gears arranged in such a way that connects the propeller shaft with the rear axles. The purpose of the differential is to provide the relative movement to the two rear wheels when the car is taking a turn. The torque transmitted to each wheel is, however, always equal.

## Construction.

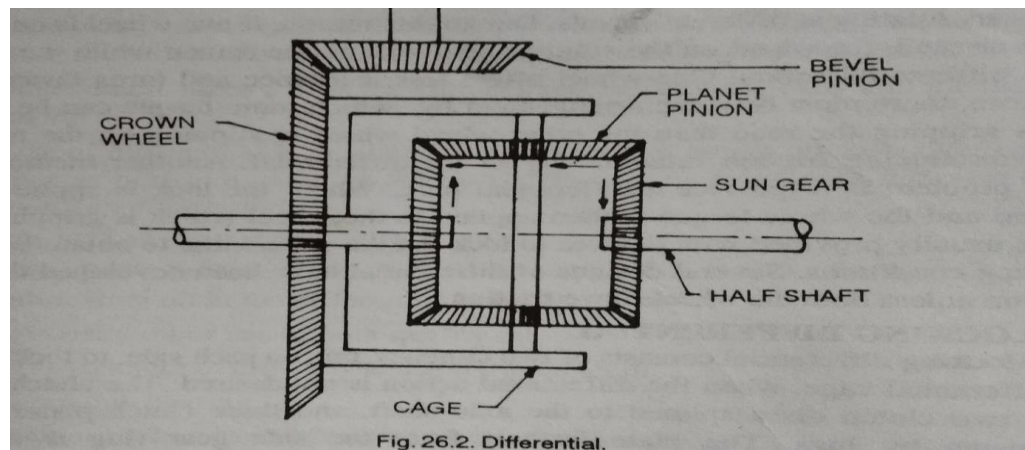

Fig.

shows the construction of a simple differential. The sun gears are mounted on the inner end of each rear axle (called the half shaft). A differential cage is assembled on the left axle. A ring gear (called the crown gear) is attached to the case, so that the cage rotates with the crown gear. The crown gear is driven by the bevel pinion. Both the crown wheel and cage are free on the left rear axle. The cage supports two planet pinions (called the differential pinion gears) on a shaft which mesh with the two sun gears. Thus, when the differential cage is rotated, both the sun gears rotate and thus both wheels turn which are attached to the outer end of the rear axles. Now let us suppose that one wheel is held stationary. Then when the differential cage is rotated, the planet gears will also rotate as they run around on the stationary axle sun gear. While rotating in this manner, the planet pinions carry rotary motion to the other axle sun gear, causing it, and the wheel too, to rotate. Therefore, when one rear wheel turns more rapidly than the other, while the

car is taking a turn, the planet gears spin on its shaft transmitting more rotary motion to one rear wheel than to the other. When both the wheels turn at the same speed the planet pinions and the sun gears all turn as a unit without any relative motion. But when the car takes a turn, the planet pinions rotate on their shaft to permit the outer rear wheel to turn more rapidly than the inner wheel.

Generally differential two types

1. conventional type
2. self locking type

### **QUESTION :**

- 1. What is chesis ?**
- 2. What is the function of clutch?**
- 3. What is the function of differentioal?**
- 4. What is the need of slip joint and universal joint ?**
- 5. What is the function of gear box ?**

### **Long Question :**

- 1. Explain major components of chesis with figure ?**
- 2. Expalin the working of single plate clutch ?**
- 3. Describe the function of differential with sketch ?**
- 4. Expalin 4 speed gearbox with sketch ?**

## **CHAPTER - 02**

### **BRAKING SYSTEM**

2.1 :-Brakes are applied on the wheels to stop the vehicle. Before applying the brakes, the acceleration is released to stop the fuel supply thus the engine develops no more power to run the vehicle, and then the brakes are applied which stop the rolling of the wheels on the road and hence the vehicle is stopped. Clutch is also disengaged which disconnects the engine from the transmission system. Thus, when the vehicle is standing, the engine is still running at idling.

#### **FUNCTIONS OF THE BRAKES**

There are two distinct functions of the brakes

- 1.To stop or slow down the vehicle in the shortest possible distance in emergencies.
- 2.To control the vehicle to be retained when descending a hill.

#### **CLASSIFICATIONS OF BRAKES**

The automobile brakes are classified according to the different bases as follows

- 1.With respect to application

Foot brake    hand brake

- 2.With respect to the number of wheels

Two wheel brakes                                  four wheel brakes

3. With respect to the method of braking contact  
Internal expanding brakes          external contraction  
brakes.

4. With respect to the method of applying the braking  
force.

Single acting brakes          double acting brakes

5. With respect to the brake gear

mechanical brakes          power brakes

6. With respect to the nature of power employed

Vacuum brakes          air brakes

7. with respect to power transmission

Direct acting brakes          geared brakes

8. with respect to power unit

Cylinder brakes          Diaphragm brakes.

## 2. Mechanical Brakes

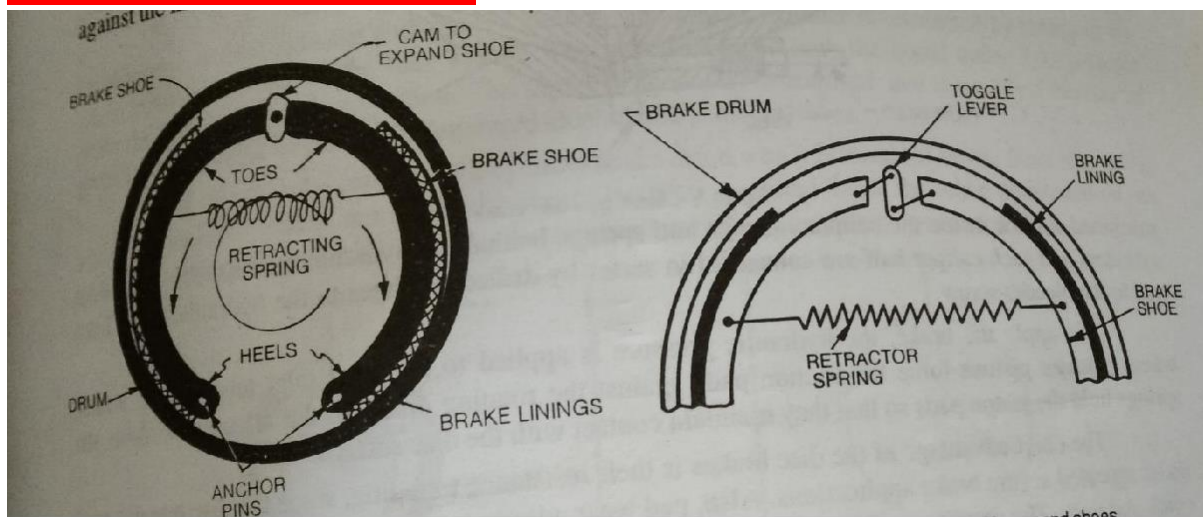

In a motor vehicle, the wheel is attached to an auxiliary wheel called drum. The brake shoes are made to contact this drum. In most designs, two shoes are used with each drum to form a complete brake

mechanism a teach wheel.; the brake shoes have brake linings on their outer surfaces. Each brake shoe is hinged at one end by an anchor pin, the other end is operated by some means so that the brake shoe expands outwards the brake lining come into contact with the drum. Retracting spring keeps the brakes shoes into position when the brakes are not applied. The drum encloses the entire mechanism to keep out dust and moisture. The wheel attaching bolts on the drum are used to contact wheel and drum. The braking plate completes the brake enclosure, holds the assembly to the car axle, and acts at the base for fastening the brake shoes and operating mechanisms. The shoes are generally mounted to rub against the inside surface of the drum to form an internal expanding brake.

When the brake pedal is pressed, the cam turns by means of brake linkage. When the cam turns, the shoes expands outwards against the drum. A toggle lever is also used for the same purpose, as shown in Fig.

. the brake linings rub against be drum and thus strip its motion. The entire mechanical linkage between the brake pedal and the shoes operates to transmit pedal force to the brake shoes, and to multiple that force through leverage to produce effective braking forces against the drum.



## 2.3-HYDRAULIC BRAKES

The hydraulic brakes are applied by the liquid pressure. The pedal force is transmitted to the brake shoe by means of a confined liquid through a system of force transmitted to all the brake shoes by a force transmission system. This system is based upon Pascal's principle, which states that "the confined liquids transmit pressure without loss equally in all direction".

Fig. 31.4 shows hydraulic consists of two main component

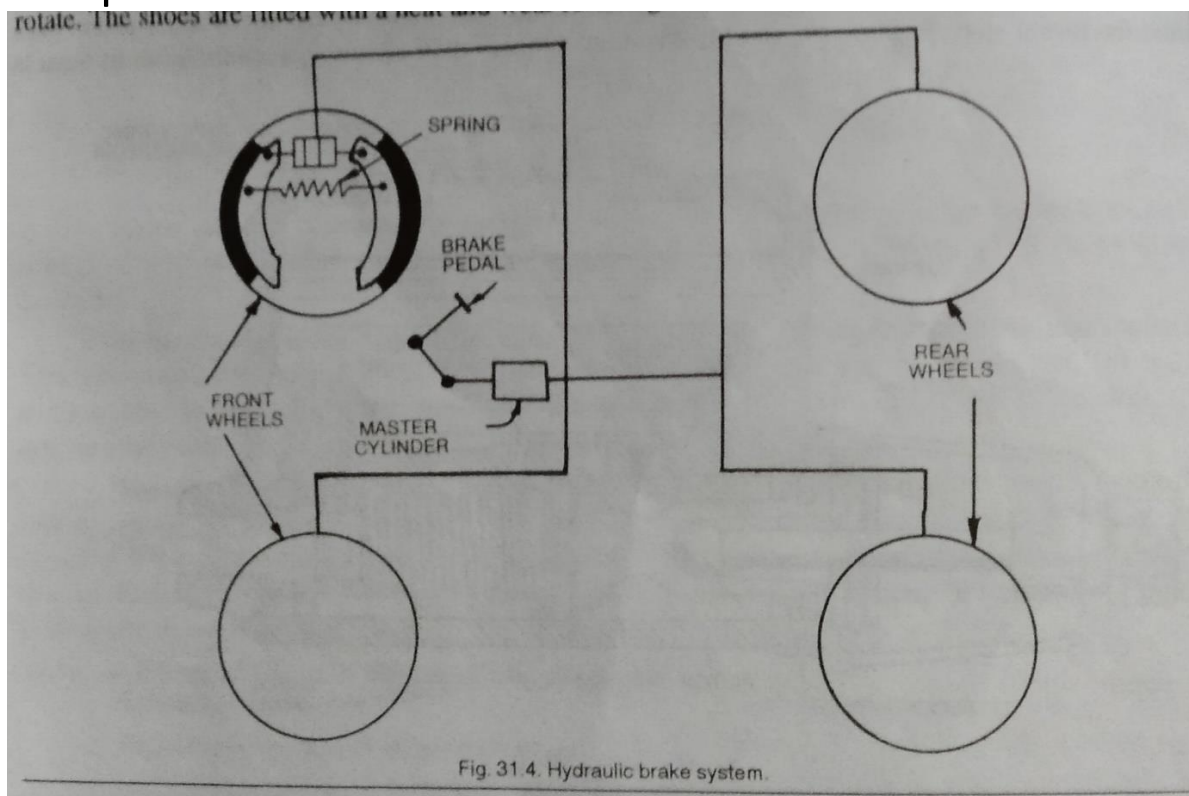

s master cylinder and wheel cylinder. The master cylinder is connected by tubing to the wheel cylinders at each of the four wheels. The system is filled with the liquid under light pressure when the brakes are not in

operation. The liquid is known as brake fluid, and is usually a mixture of glycerine and alcohol or castor oil, denatured alcohol and some additives.

Each wheel brake consists of a cylinder brake drum which is mounted on the inner side of the wheel and revolves with it and two brake shoes which are mounted inside the brake drums and do not rotate. The shoes are fitted with a heat and wear resisting brake lining on their surfaces.

The brake pedal is connected to the master cylinder piston by means of a piston rod. When the brakes are to be applied, the driver depresses the pedal, the piston is forced into the master cylinder, this increasing the pressure of the fluid in the master cylinder, this pressure is conducted instantaneously to the wheel cylinders on each of the four brakes, where it forces the wheel cylinder pistons outwards. These pistons, in turn, force the brake shoes out against the brake drums. Thus the brakes are applied.

When the driver releases the brake pedal, the master cylinder piston returns to its original position due to the return spring pressure, and thus the fluid pressure in the entire system drops to its original low value, which allows retraction spring on wheel brakes to pull the brake shoes out of contact with the brake drums into their original positions. This causes the wheel cylinder pistons also to come back to their original inward position. Thus the brakes are released.

## **:-AIR BRAKES**

The manufacturers of braking systems offer a variety of air brake equipment. However, the simplest system consists of an air compressor a brake valve, series of brake chambers, unloader valve, a pressure gauge and a safety valve. These are all connected by lines of tubing. The other braking systems may have additional components such as stop-light switch, a low pressure indicator, an air supply valve to supply air for tyre inflation, a quick release valve to release air quickly from the front brake chambers when pedal is released , a limiting valve for limiting the maximum pressure in the front brake chamber and a relay valve to help in quick admission and release of air from rear brake chambers.

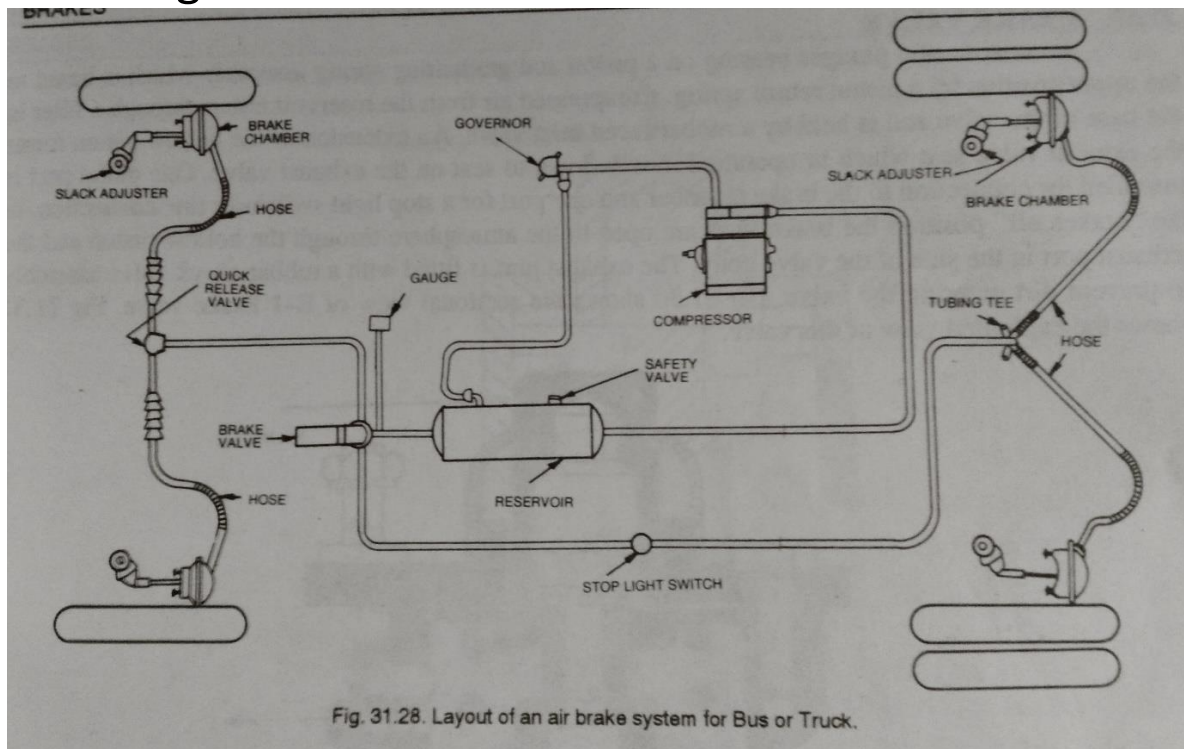

shows the layout of an air brake system for a bus or truck. The air compressor, governor, pressure gauge, safety valve and the reservoir constitute the compressing and the control units whereas the rest of them are termed as application units. The compressed air available on the vehicle is also used for the operation of additional assemblies of the vehicle such as horn, windshield wipers, etc.

The compressor sends compressed air to the reservoirs which are connected to the brake valve. The lines of tubing from the brake valve extend to the front and rear brake chambers. When the driver depresses the pedal, it operates the brake valve thus admitting compressed air to all the brake chambers. The

compressed air operates the diaphragm of the brake chambers thereby applying the brakes.

### **:-AIR ASSISTED HYDRAULIC BRAKES**

In this type of braking system, the air pressure is converted into hydraulic pressure here the air power cylinder is combined with the hydraulic master cylinder and the reservoir, the conventional type hydraulic brakes are actuated by the air power with the help of this unit. The bore of the power cylinder is generally kept four times that of the master cylinder. The ratio between the hydraulic pressure and the air pressure is generally maintained at 15:1 in India, the commercial vehicles manufactured by M/s. Tata Engg. And Locomotive co. have air hydraulic brakes. Shows the circuit diagram of compressed air of Tata Tuck braking system compressed air brake system consists of the following components:

1. Air compressor
2. Tyre inflating bottle.
3. Air pressure regulator
4. air container
5. Truck brake valve.
6. air pressure gauge.

Compressed air delivered by the air compressor incorporated in engine is used to assist the hydraulic brake system to increase brake efficiency. Referring to it is observed that the compressed air from the compressor flows to the tyre inflating bottle to the air pressure regulator to air container and to the truck brake valves when desired.

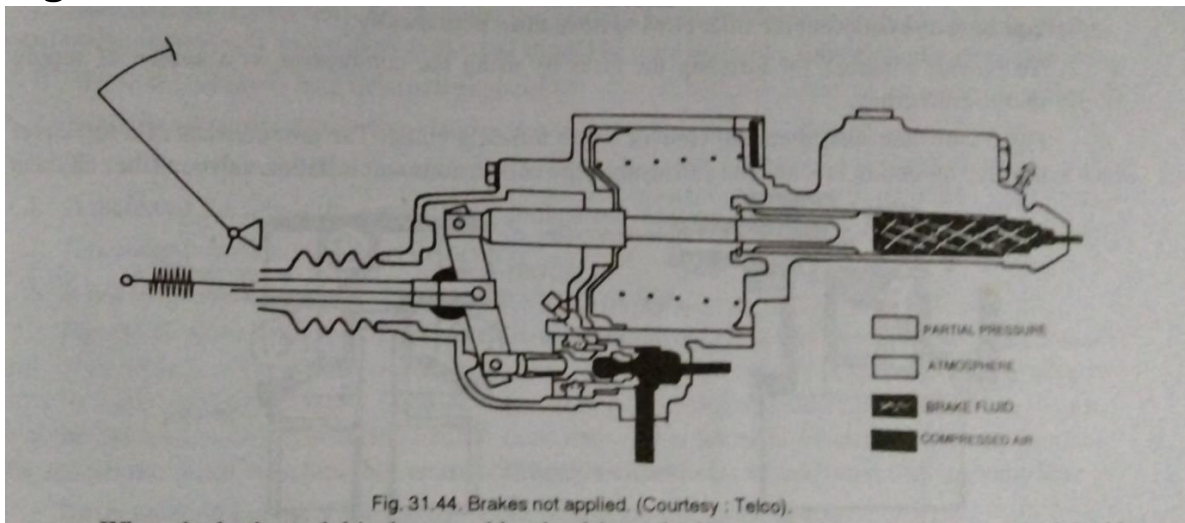

shows the position of the servo and master cylinder when brakes are not applied. It will be seen that the piston of brake valve is held against the stop on the body by the return spring. The inlet valve is kept closed on its seat on the valve body and the exhaust valve remains open. The space exhaust passage on the reaction piston and the reaction fork.

When the brake pedal is depressed by the driver, the input rod moves the lever forward. In this reaction piston and the exhaust passage is close, further movement of the input rod opens the inlet valve and air pressure is admitted into the space behind the piston through the cross hole on the body. This air pressure forces the power piston to move and this effort is transmitted to the master cylinder through the output rod. The force acting on the master cylinder thus creates the hydraulic pressure required for the application of brakes. Shows the position of the servo and master cylinder when brakes are applied.

## **:-VACUUM BRAKE**

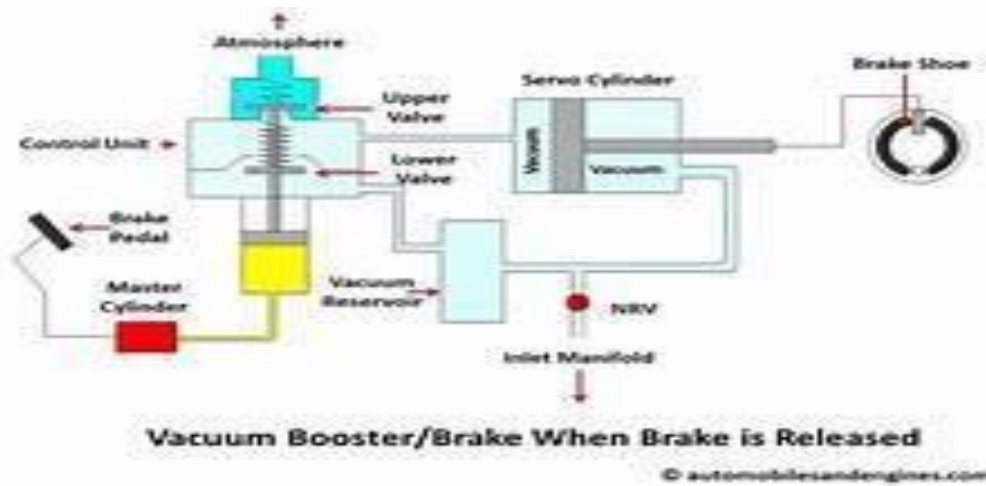

In the earliest day of railways trains were stopped or slowed by manually applied brakes. A major advanced was the adoption of a vacuum brake in which flexible pipe wire connected between all the vehicles of the train. the simple vacuum system had the major defect that in the event of one of the hoses connecting the vehicles becoming defect then the entire system was useless.

The vacuum brake is the simplest form which consists of a continues pipes. the train pipe running through out the length of the train. in the normal running a partial vacuum is maintain in the train pipe and the breaks are released. when air is admitted to the train pipe the air pressure act against the piston and cylinder in each vehicle. A vacuum is sustain on the other face of piston so that a net force is applied. A mechanical linkage transmit this force to the brake

show which act on the thread of the wheel. the brake cylinder contain in a longer housing this gives a reserve of vacuum as the piston operation.

### SHORT QUESTION

- 1, What is the function of brake ?
2. What is vaccum brake ?
3. Write down the components of hydraulic brake ?
4. Write down the components of mechanical brake ?

### Long Question

1. Explain mechanical brake with sketch ?
2. Explain Hydraulic brake with figure ?
3. Explain vacuum brake with sketch ?



## **CHAPTER - 03**

### **IGNITION AND SUSPENSION SYSTEM**

The spark ignition engines require some device to ignite the compressed air fuel mixture inside the cylinder at the end of the compression stroke. Ignition system serves this purpose. It is a part of electrical system which carries the electrical current to spark plug which gives spark to ignite the air fuel mixture at the correct time. The ignition system consists of a battery, switch, ignition distributor, ignition coil, spark plugs and necessary wiring. Some systems use transistors to reduce the load on the distributor contact points. Other systems use a combination of transistors and a magnetic pick up in the distributor.

#### **TYPES OF IGNITION SYSTEM**

There are two types of ignition systems used in petrol engines:

1. Battery ignition system
2. Magneto ignition system

Both the ignition systems are based on the principle of mutual electromagnetic induction. The battery ignition system is mostly used in passenger cars and light trucks. In the battery ignition system, the current in the primary winding is supplied by the battery whereas in magneto ignition system, the magneto produces and supplies the current in the primary winding.

### 3.1:-BATTERY IGNITION SYSTEM

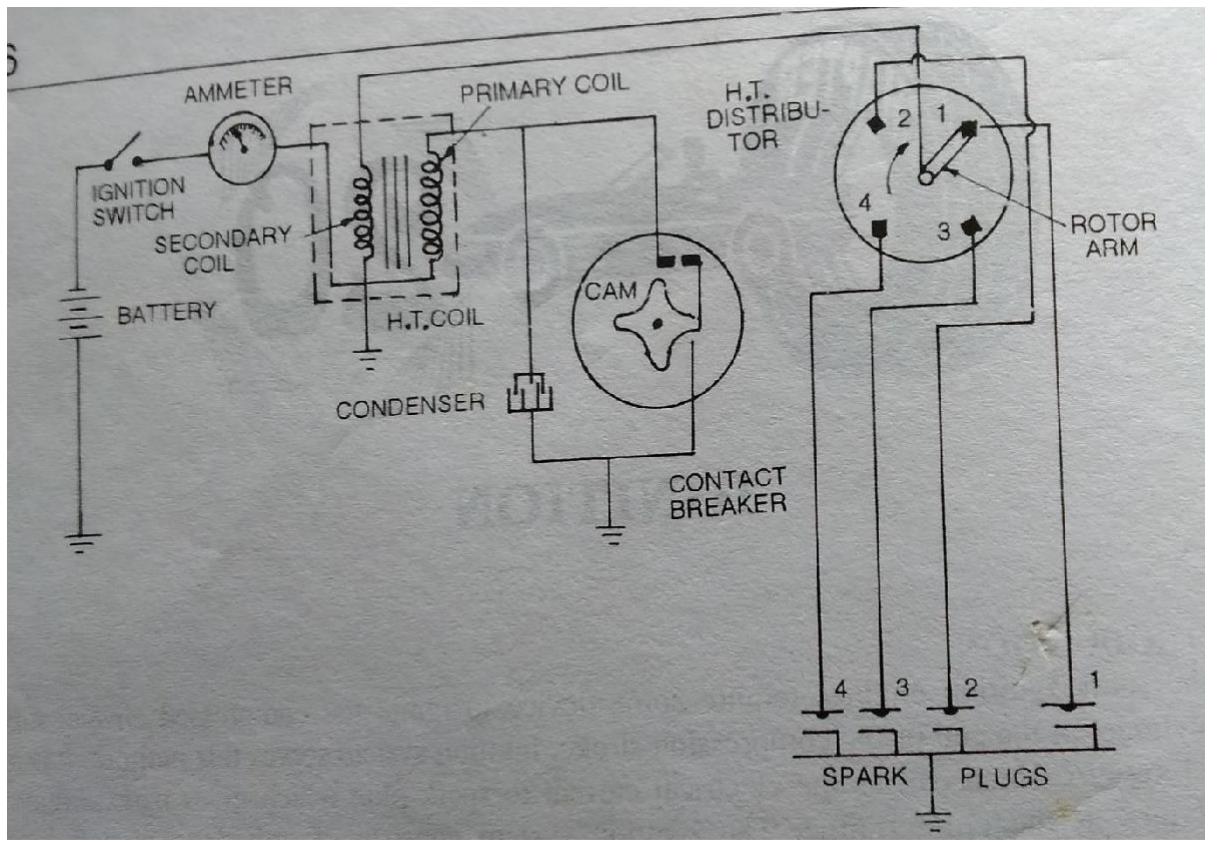

Battery ignition system for a four-cylinder engine. It consists of a battery, ammeter, switch, ignition coil, condenser, contact breaker, distributor and spark plug.

The primary ignition circuit starts at the battery and passes through the switch, ammeter, primary winding, contact breaker points to the ground. A condenser is also connected in parallel to the contact breaker points. One end of the condenser is connected to the contact breaker arm and the other end is grounded.

The secondary ignition circuit is not connected electrically to the primary ignition circuit. It starts from

the ground and passes through the secondary winding, distributors, spark plug to the ground.

The ignition coil steps up 6 to 12 volts from the battery to the high tension voltage of about 20000 to 30000 volts required to jump the spark at the spark plug gap, which ignites to combustible charge in the cylinder. The rotor of the distributor revolves and distributes the current to the four segments which in turn. Send it to the spaerk plugs. The purpose of the condenser is to reduce arcing at the breaker points and thereby prolong their life. Because the ignition system is of four cylinder engine, the cam of the contact breaker has four lobes. It makes end breaks the contact of the primary circuit four times in every revolution of the cam.

When the ignition switch is on, the current will flow from the battery through the primary winding. It produces magnetic field in the coil. When the contact points open, the magnetic field collapses and the movement of the magnetic field induces current in the secondary winding coil.

## **:-MAGNETO IGNITION SYSTEM**

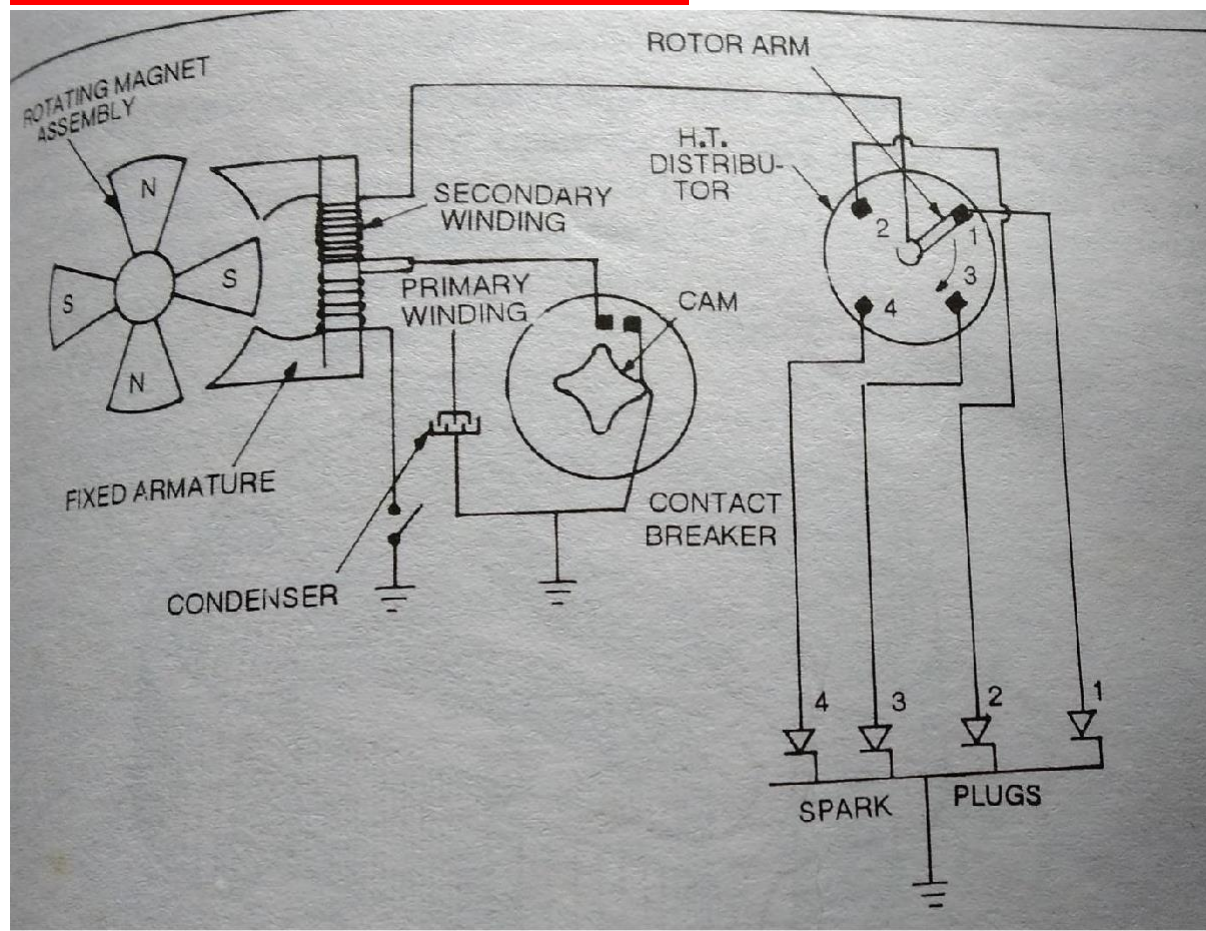

Magneto ignition system for a four-cylinder engine. It consists of a magneto, instead of a battery, which produces and supplies current in the primary winding. The remaining arrangement in this system is the same as that in the battery ignition system. The magneto consists of a fixed armature having primary and secondary windings and a rotating magnetic assembly which is driven by the engine. When the magnets rotate, current flows in the primary winding. The secondary winding gives high voltage current to

the distributor, which distributes it to the respective spark plugs.

The magneto may be either rotating armature type magneto, the armature carrying the primary and secondary windings and condenser, rotate between the poles of a stationary horse shoe magnet.

### **SPARKPLUG**

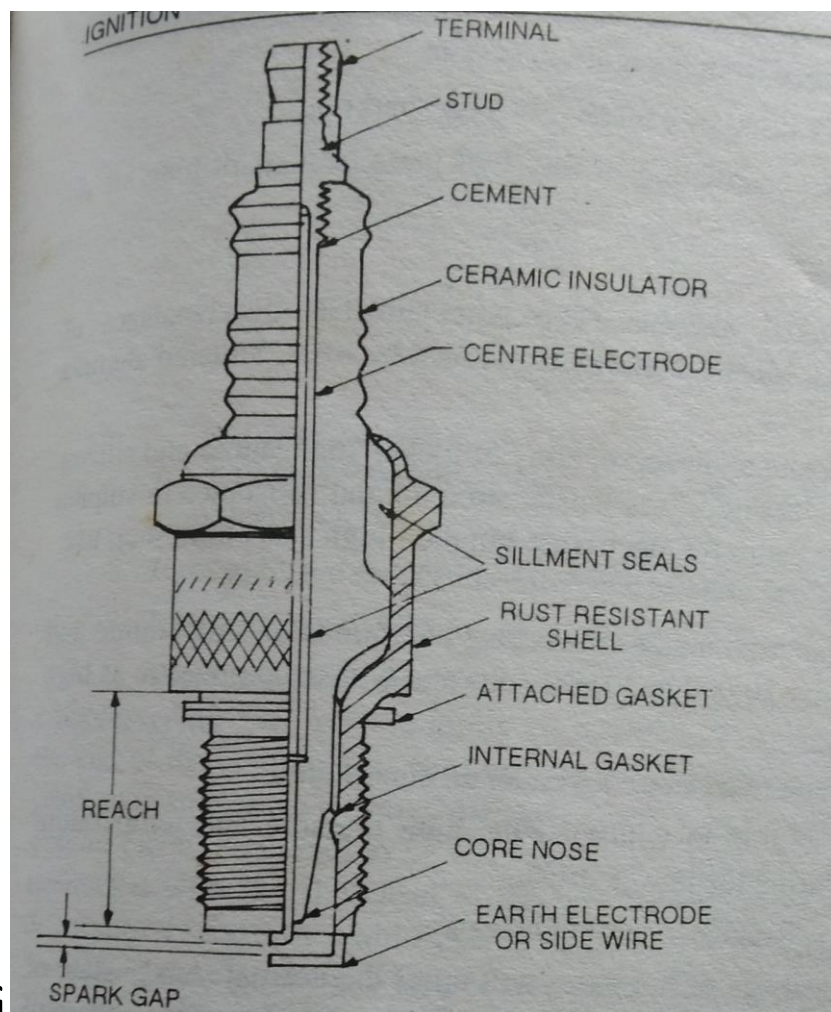

SPARK PLUG

Spark plug is a device to produce electric spark to ignite the compressed air fuel mixture inside the cylinder. The spark plug is screwed in the top of the

cylinder so that its electrodes projects in the combustion chamber.

Construction. A spark plug consists of mainly three parts:

1. Centre electrode or insulated.
2. Ground electrode or outer electrode.
3. Insulation separating the two electrodes.

The upper end of the center electrode is connected to the spark plug terminal, where H.T. cable from the ignition coil is connected. It is surrounded by porcelain insulator. The lower half portion of the insulator is fastened with a metal shell. The lower portion of the shell has a short electrode attached top open side and bent in towards the center electrode, so that there is a gap between the two electrodes, the two electrodes are thus separated by the insulator. The sealing gaskets are provided between the insulator and the shell to prevent the escape of gases under various temperature and pressure conditions. The lower part of the shell has screw threads and the upper part is made in hexagonal shape like a unit, so that the spark plug may be screwed in or unscrewed from the cylinder head.

In some engines, a sealing gasket is also provides a seal between the two parts as well as aids in the conduction of heat. In other designs, a tapered fit is used. Some speak plugs are provided with a built in

resistor, which forms part of the centre electrode. The resistor serves two purposes.

1. It reduces radio and television interference from the ignition system.
2. It reduces spark plug electrode erosion caused by excessively long sparking .

Materials. The materials used in the construction of different parts of a spark plug are as follows:

1. **Shell.** sheet .
2. **Insulation.** Porcelain, mica, sintered alumina. The porcelain has disadvantages of brittleness and low resistance to thermal shocks. Mica is somewhat attacked by fuels. Sintered alumina is now almost extensively used for insulation.
3. **Electrode.** Nickel, alloy of nickel and manganese, alloy of nickel,. Manganese and silicon. Platinum alloy, addition of manganese improves tensile strength and resistance to sulphur attack at high temperatures. Platinum alloys are better for electrodes, but their high costs limit their use.

## Common trouble and Remedy

TROUBLELES	REMEDY
1.Heavy erosion of center electrode	1.fit new spark plug
2.incorrect gap between electrodes	2.correct gap should be maintain between electrodes by the help of filler gauge
3.center electrode melted	3.check the engine tune off and distributor
4.insulator tip breakage	4.check engine and fit new spark plug.
5.deposite of piston materials	5.check the engine ignition timing setting and carburetor setting

### **:- Conventional suspension system for rear axle**

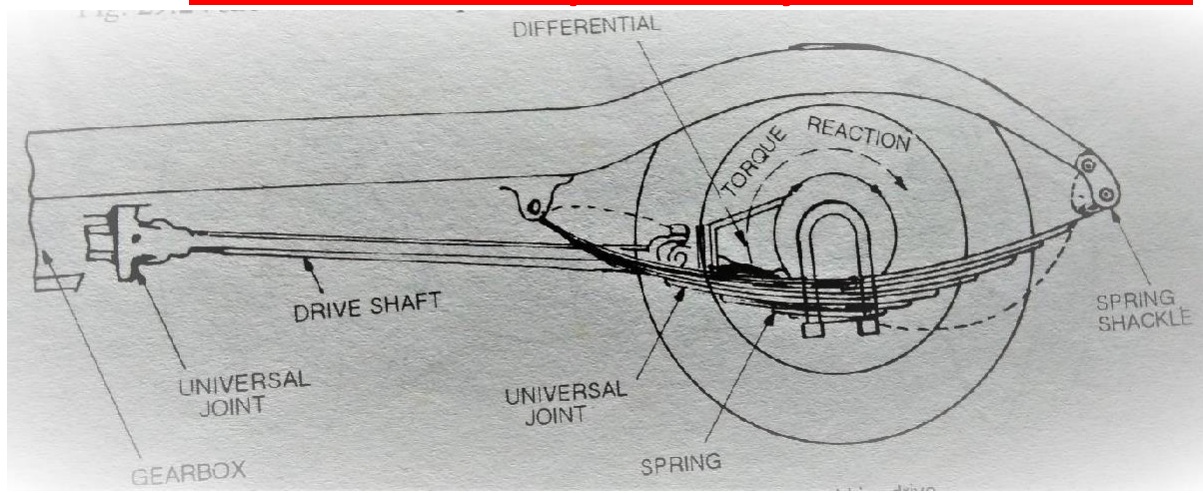

Fig. shows conventional suspension system. This type of suspension is always used in conjunction with torque tube, torque reaction link, or torque rod drive. Therefore, the coil springs are not subjected to driving



thrust or twist. Stabilizers and radius rods are also used which relieve the coil springs of all stresses except those acting in a vertical direction. The stabilizer prevents excessive roll or sideway when the car is cornering. The radius rod keeps the rear axle and frame in lateral alignment. The coil springs are seated in pan shaped brackets – spring seats attached to the rear axle.

### **:-CONVENTIONAL SUSPENSION FOR FRONT AXLE**

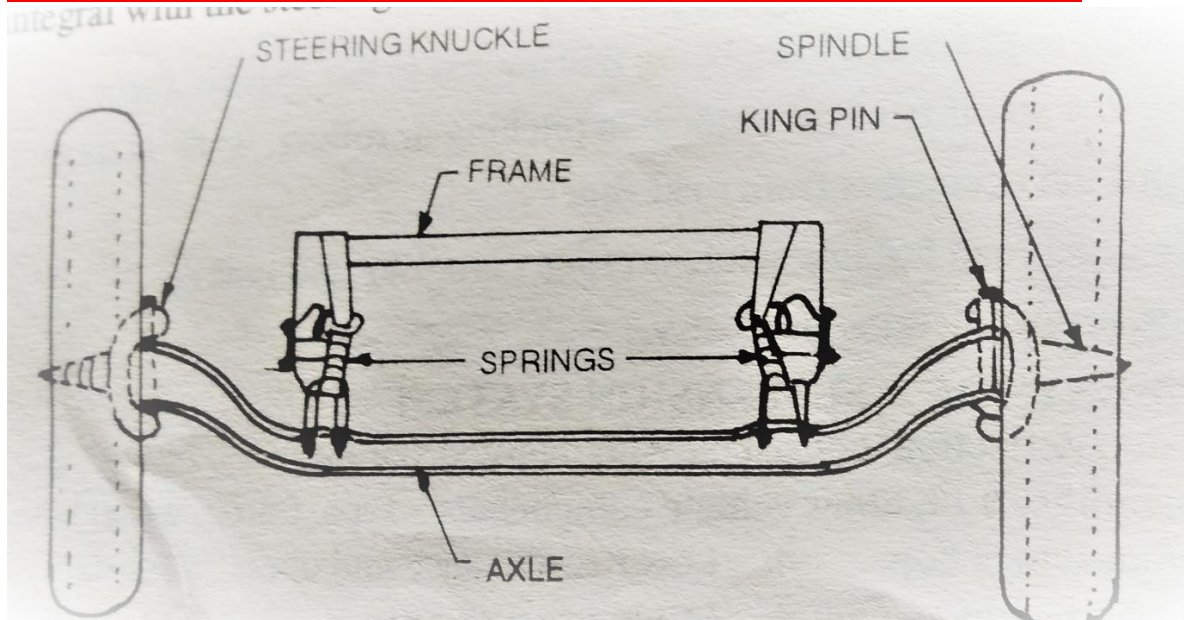

Fig. shows conventional suspension for front wheel suspension. This type of suspension was universally used before the introduction of independent front wheel suspension. It may use either two longitudinal leaf spring, as shown in the figure, or on transverse spring, usually in conjunction with shock absorbers these assemblies are mounted similarly to rear leaf spring suspensions.

In this type of suspension, the front wheel hubs rotate on antifriction bearings of steering spindles which are attached to the steering knuckles. To permit the wheels to be turned by the steering gear, the steering spindle and steering knuckle assemblies are hinged on the axle ends. The pin that forms the pivot of this hinge is usually referred to as the king pin or steering knuckle pin. Where the forked portion is integral with the steering knuckle and fits over the end of the axle, the construction is known as reverse Elliot. In Elliot type construction, the ends of the axle are forked to hold the steering knuckle extension between the ends.

### **:-INDEPENDENT SUSPENSION SYSTEM**

In the independent type of front suspension, each front wheel is independently supported by a coil, torsion bar or leaf spring. Almost all the passenger cars now use the independent front suspension, in which the coil spring arrangement is the most common.

There are three types of coil spring front suspension:

1. In the first type, the coil spring is located between the upper and lower control arms. The lower control arm has one point attachment to the car

frame.

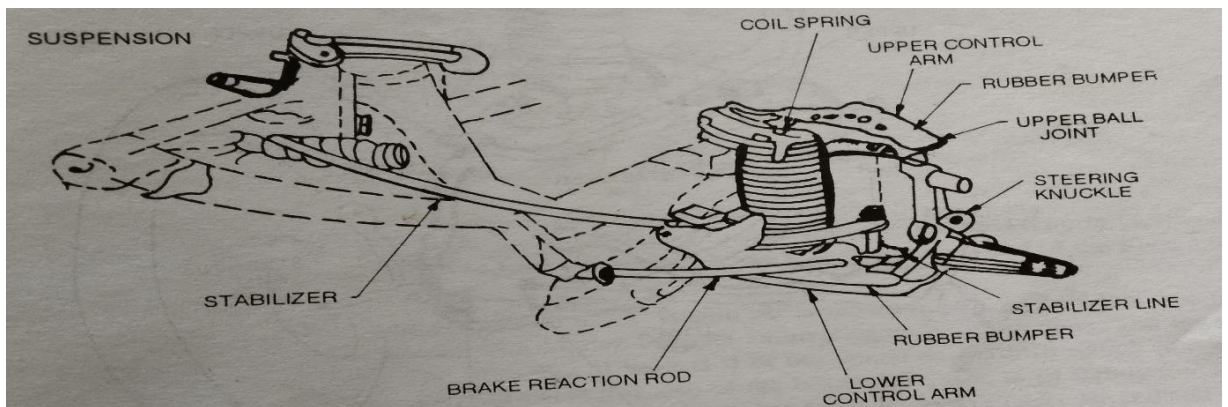

2. In the second type, the coil, spring is located between the upper and lower control arms. The lower control arms has two points to attachment to the car frame.

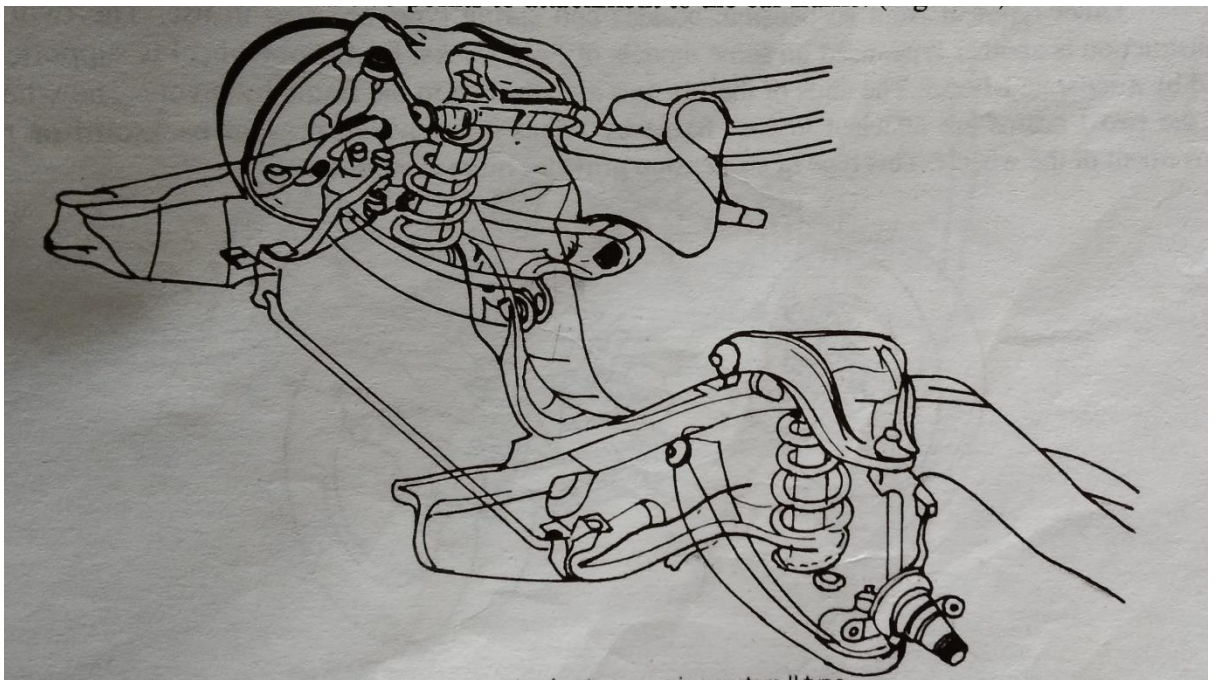

3.

3. In the third type, the coil spring is between the upper control arm and spring tower or housing that is part of the front-end sheet-metal work.

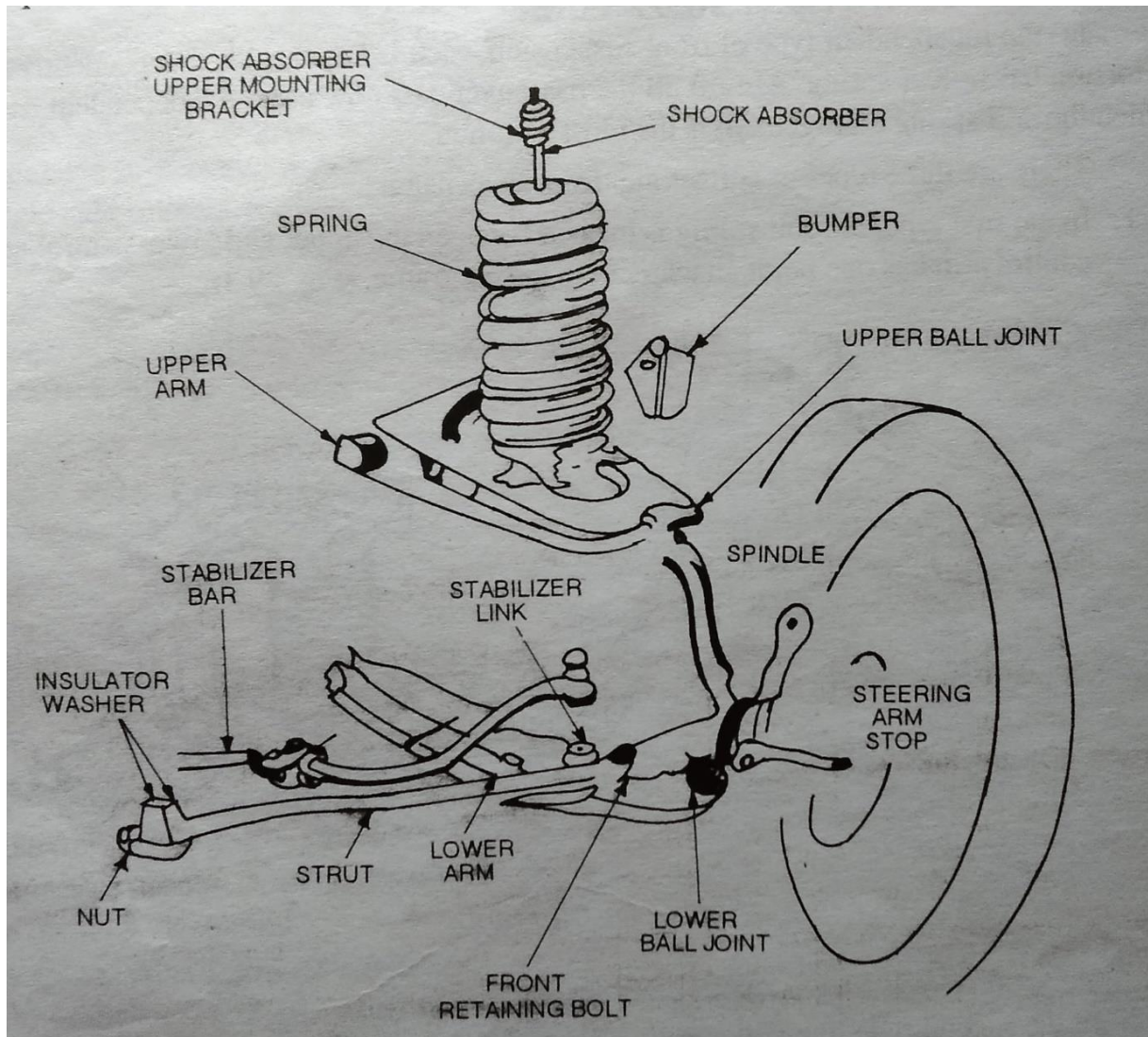

Other types of front suspension, besides coil spring type, are also in use. The twin I-beam construction is another type, used on some models of Ford trucks. Each front wheel is supported at the end by a separate I-beam. The ends of the I-beams are attached to the frame by pivots, the wheel ends of the two I-beam are attached to the frame by radius arms, which prevent backward or forward movement of the wheels. This type of suspension provides more flexibility.

## **:-TELESCOPIC SHOCK ABSORBER**

A simple diagram of the telescopic shock absorber is shown in fig. . Its upper eye is connected to the axle and the lower eye to the chassis frame. A two way valve A is attached to a rod G. another two way valve B is attached to the lower end of cylinder C. the fluid is in the space above and below the valve A, and also in the annular space between the cylinder C and tube D, which is connected to the space below the valve B. The head J has a gland H. any fluid scrapped off by the rod G is brought down into the annular space through the inclined passage.

The shock absorber works as follows : when the vehicle comes across a bump the lower eye E moves up. Therefore, the fluid passed from the lower side of the valve A to its upper side. But since the volume of the space above valve A is less than the volume of the rod G, the fluid exerts pressure on the valve B. this pressure of the fluid through the valve opening provides the damping force. Similarly, when the lower eye E moves down, the fluid passes from the upper side of the valve A to the lower side, and also from the lower side of the valve B to its upper side.

The shock absorber must be filled with shock absorber fluid at regular intervals as recommended by the manufacturer or when required by its condition. The modern telescopic shock absorbers are no longer

serviced. If they leak or do not offer proper resistance to push and pull, they should be replaced.

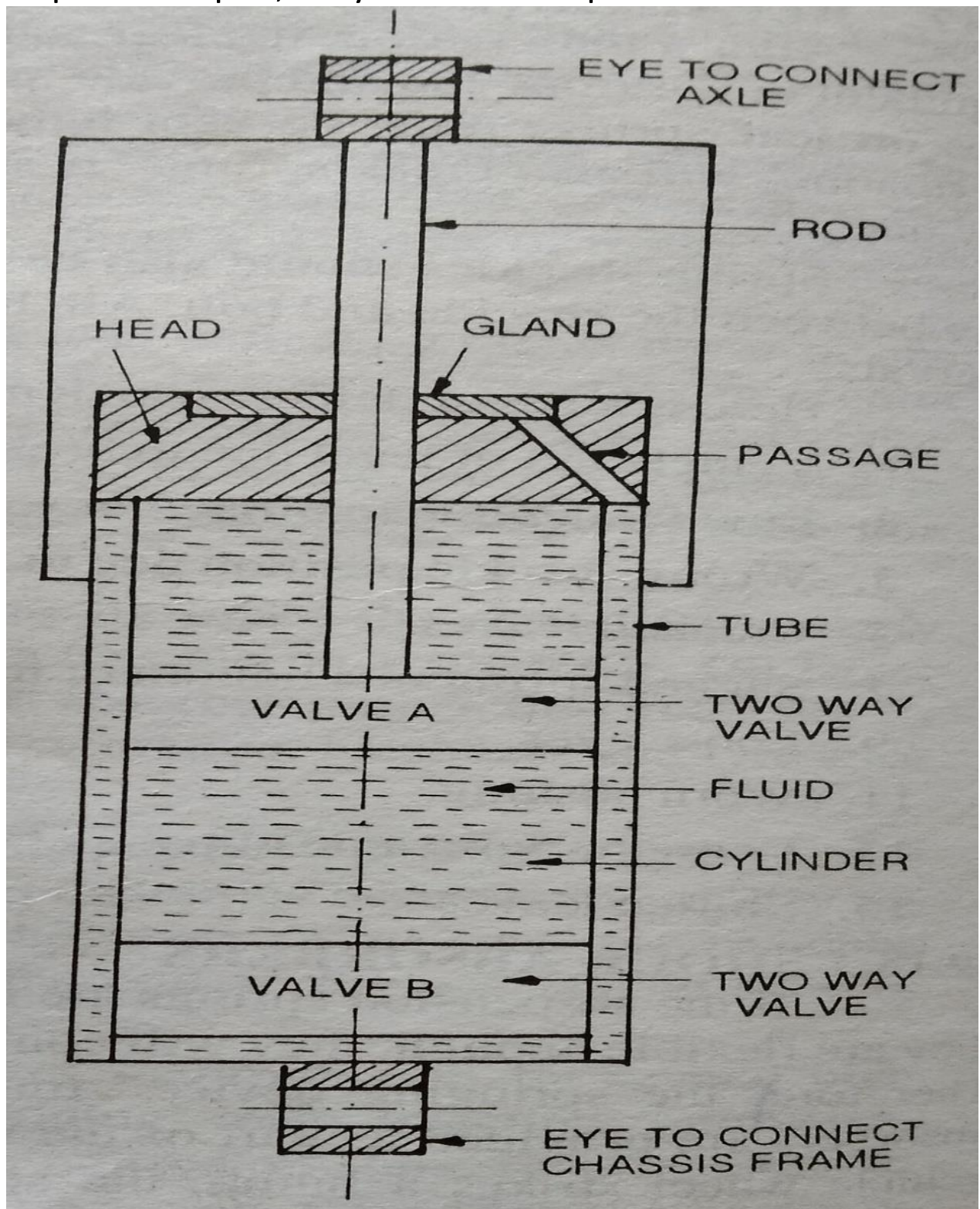

### **SHORT QUESTION**

1. What is sparkplug ?
2. What is SI and CI Engine ?
3. What is the function of suspension system ?
4. Write down the types of Ignition system ?
- 5.

### **LONG QUESTION**

1. Describe the construction of spark plug ?
2. Describe battery ignition system with figure ?
3. Describe magnetor ignition system ?
4. Explain conventional suspension system of front and rear axle ?

## Chapter – 04

### COOLING AND LUBRICATION

#### **Engine cooling : Need and classification**

During the combustion of air fuel mixture enormous amount of heat is produced inside the engine cylinder, and the temperature as high as 2500 c may be reached by the burning gases. The temperature is so high that it will break the lubricating film between the moving parts, weld the moving parts or may cause any mechanical breakage of the engine parts. Hence this temperature must be reduced by some means to such a value, about 200c 250 c, at which the engine may work at the cooling system is to keep the engine at its most efficient operating temperature at all engine speeds and all driving conditions. About 15% of the total heat produced is utilised for useful work at the crankshaft. Remaining amount of heat is absorbed in friction, removed by exhaust gases and taken by cooling system. The cooling system. The cooling system is designed to remove above

30 to 35% of heat produced in the engine cylinder. When the combustion takes place, the cylinder walls, cylinder head, piston and valves are heated. Their temperature should not reach excessive values. They must be cooled by some means to a desirable temperature. It is also to be noted that the engine is quite inefficient when cold. The cooling system is so designed that it prevents cooling until the engine reaches to its normal operating cooling system is so designed that it prevents cooling system begins to function. It cools rapidly when the engine is too hot, and it cools slowly or not at all when the engine is cooled or is warming up. Most engines are designed to operate in a definite temperature range which will insure correct clearances between parts, promote vaporization of the fuel, keep the oil at its best viscosity and prevent the condensation of harmful vapour. Thus the duty of the cooling system is to keep the engine from getting too hot not to keep it cool.



There are following types of cooling system are generally used in automobile sector.

- |                   |                  |
|-------------------|------------------|
| 1. Air cooling    | 2. Water cooling |
| 3. Liquid cooling | 4. Steam cooling |

***Defect of cooling and their remedial measures.***

<b>DEFECTS</b>	<b>REMEDIES</b>
1- Water pump failure	1-Water pump should be repaired and replaced .
2- Noise	2-Noise should be minimized by proper maintainance.
3- Over heating	3-Over heating causes such as circulation of water, improper valve timing and ignition timing should be find out and rectified.
4- Radiator leak	4. Radiator leak should be repaired or it should be changed.
5- Over cooling	5- Over colling caused should be find out such as thermostart valve working should be properly maintained.
6- Loss of liquid coolant due to leaks	6- Leaks should be repaired asper the requirement.

**Function of Lubrication.**

1. To minimize friction and wear.
2. To cool by carrying away heat.
3. To seal the piston and thus preventing escape of gases in the cylinders with consequent loss of power.
4. To cushion the parts against vibration and impact.
5. To clean the parts as it lubricates them, carrying away impurities.

**Lubrication system of I.C Engine**

The different systems for lubricating the automobile engine are as follows:

- |                      |                         |
|----------------------|-------------------------|
| 1. Petroil system.   | 2. Spalash system.      |
| 3.Pressure susestem. | 4.Semi pressure system. |
| 5. Dry sump system.  |                         |

**Petrol system.** This system of lubrication is generally adopted in two stroke petrol engine like scooters and motor cycles. It is simplest form of lubricating system. It does not consist of any separate part, like oil pump, for the purpose of lubrication. But the lubricating oil is mixed into the petrol itself while filling in the petrol tank of the vehicle, in a specified ratio. When the fuel goes into the crank chamber during the engine operation, the oil particles go deep into the bearing surfaces and lubricate them. The piston rings, cylinder walls, piston pin, etc. are lubricated in the same way.

If the engine is allowed to remain unused for a considerable time, the lubricating oil separates off from petrol and leads to clogging of passages in the carburetor, resulting in the engine starting trouble. This is the main disadvantage of this system.

**Splash system.** In this system of lubrication, the lubricating oil is stored in an oil trough or sump. A scoop or dipper is made in the lowest part of the connecting rod. When the engine runs, the dipper dips in the oil once in every revolution of the crankshaft and causes the oil to splash on the cylinder walls. This action affects the lubrication of the engine walls, piston ring, crankshaft bearings and big end bearings.

Splash system mostly works in connection with pressure system in an engine, some parts being lubricated by splash system and the other by pressure system.

fig.

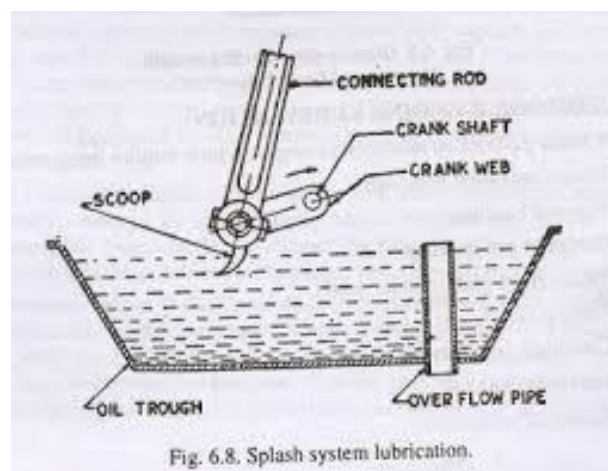

## Pressure system.

In this system of lubrication, the engine parts are lubricated under pressure feed. The lubricating oil is stored in a separate tank or the sump, from where an oil pump takes the oil through a strainer and delivers it through a filter to the main oil gallery at pressure of 2-4 kg/cm . The oil from the main gallery goes to the main bearings, from where some of it after lubrication the main bearing, falls back to the sump, some is splashed to lubricate the cylinder walls and the remaining goes through a hole to the crankpin. From the crank pin it goes to the piston pin through a hole in the connecting rod web, where it lubricates the piston rings.

Fig.

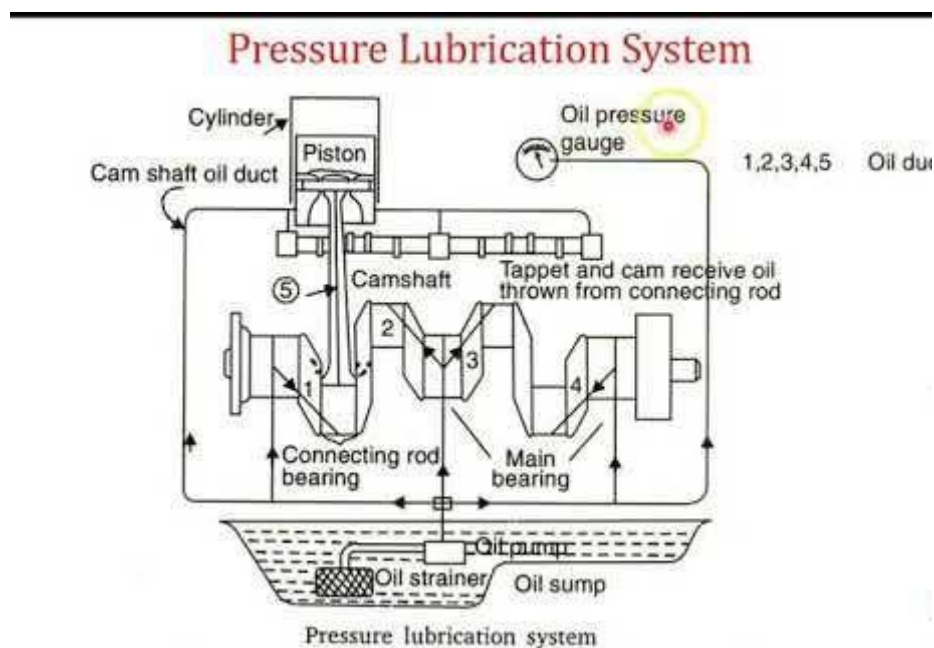

For lubricating camshaft and timing gears, the oil is led through a separate oil line from the oil gallery. The valve tappets are lubricated by connecting the main oil gallery to the tappet guide surfaces through drilled holes.

An oil pressure gauge at the instrument panel indicates the oil pressure in the system. Oil filters and strainers in the system clear off the oil from dust, metal particles and other harmful particles.

## Dry sump system.

The system in which the lubricating oil is stored in the oil sump is called wet sump system, like the pressure system. But the system in which the lubricating oil is not kept in the oil sump is known as dry sump system. In this system, the oil is carried in a separate tank from where it is fed to the engine. The oil which falls into the oil sump after lubrication, is sent back to the oil tank by a separate delivery pump. Thus, the system consists of two pumps, one to feed the oil and the other to deliver it back to the oil tank. This system is used in situations where the vehicle has to change its position continuously, like in aircraft. The main advantage of this system is that there is no chance of breakdown the oil supply during up and down movement of the vehicle.

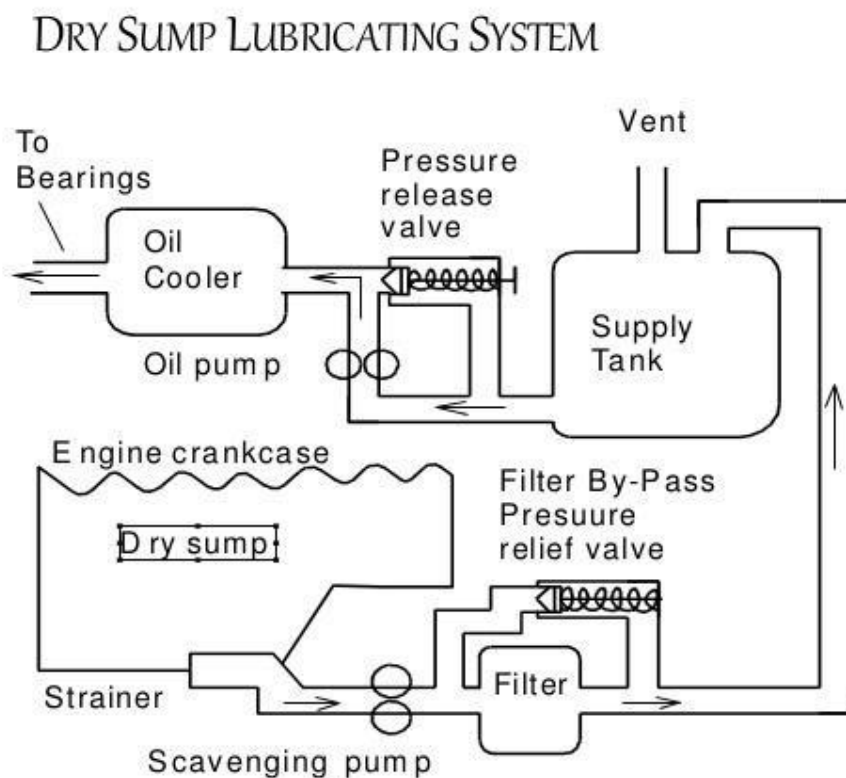

### **Short Questions**

1. What is function of cooling system?
2. What is the function of thermostat valve?
3. What is the main function of lubrication system?

### **Long Questions**

1. Describe various type water cooling system?
2. Describe various type lubrication system?
3. Describe function of lubrication?

## Chapter 5. FUEL SYSTEM

### Air fuel ratio.

The carburettor must supply the air fuel mixture of varying proportions to suit the different operating requirements. The mixture must be rich for starting, and must be relatively lean for idling and intermediate speeds. Fig. shows the air fuel ratio for different speeds of a car. For starting, the air fuel ratio is 9:1. It is a rich mixture. For idling, the ratio is 12:1. It is a lean mixture. For intermediate speeds, between 35 to 105 km/hr, the mixture further leans at 15:1. But at higher speeds mixture further leans out 120 to 150 km/h, with a wide open throttle, the mixture is again enriched to about 13:1. For acceleration at any speed the throttle is suddenly opened which causes a momentary enrichment of the mixture. Two examples of acceleration are shown by dotted lines, one at 25 km/h and the other at 45 km/h.

fig.

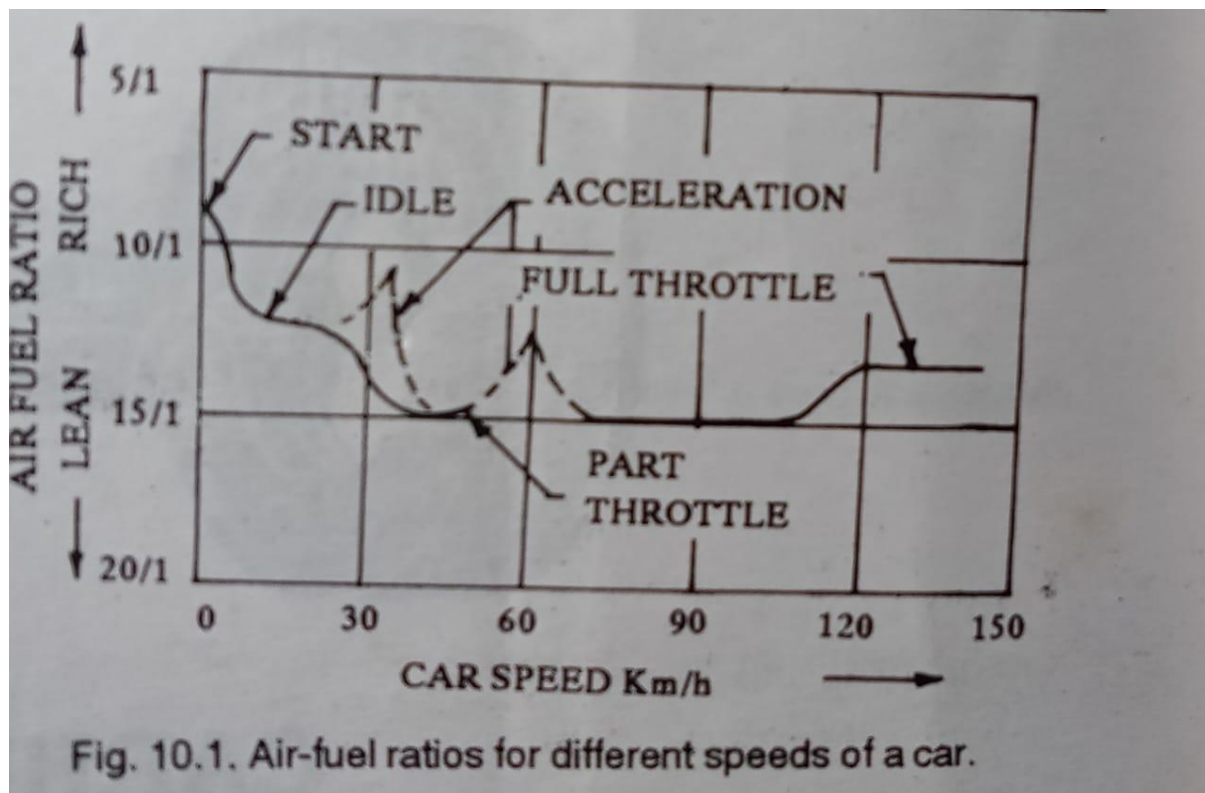

## **Carburetion process for petrol Engine**

The carburettor is a device for atomizing and vaporizing the fuel and mixing it with the air in varying proportions to suit the changing conditions of spark ignition engines. The air fuel mixture so obtained from the carburettor is called the combustible mixture. The process of mixture the petrol fuel with air to obtain the combustible mixture is called carburetion.

Hence the terms vaporization and atomization should be understood clearly. vaporization is the change of state of the fuel from liquid to vapour. Atomization is the mechanical breaking up of the liquid fuel into small particles so that every particle of the fuel is surrounded by air. In order to produce very quick vaporization of the liquid fuel, it is sprayed into the air passing through the carburettor. Spraying of the liquid turns it into many fine particles, so that the vaporization occurs almost instantly.

## **Multi Point Fuel Injection System.**

Automobiles use one of two devices for supplying the air fuel mixture in correct ratio to the cylinders in all rpm ranges ; a carburettor or an Multi Point Fuel Injection Electronic Fuel Injection system. Both of these measure the intake air volume, which varies depending on the opening angle of the throttle valve and the engine rpm, and they both supply a proper ration of fuel and air to the cylinders in accordance with the volume of intake air. The MPFI and EFI is the same reference of the system. Because the construction of h carburetor is relatively simple, it has been used almost exclusively on petrol engines in the past. However, in response to recent demands for cleaner exhaust emissions, more economical fuel consumption, improved drivability, etc., the carburetor now must be equipped with various compensating devices, making it more complex system.

In place of the carburetor therefore the MPFI system is used, assuring the proper air fuel ratio to the engine by electrically injecting fuel in accordance with various driving conditions. The MPFI, however, calibrates the fuel at optimum requirement fuel as desired by engine. The fuel is controlled not only by manual but so many other sensors. Carburetors atomize the fuel by processes relying on the air speed being greater than the fuel speed at the fuel nozzle. They also meter the fuel using the air flow as the independent variable. Fuel injection differs in both respects. The fuel speed at the point of delivery is greater than the air speed to atomize the fuel and the fuel is metered proportionally to air flow but not by the air flow itself; rather a pump is used to generate the pressure difference necessary to flow the fuel.

### *Working principle of fuel injection system for multi cylinder engine.*

There are two methods of fuel injection in compression ignition engines:

- 1- Air blast injection.
- 2- Airless or solid injection.
  - (a) Individual pump system
  - (b) common rail system.

Air blast injection. This method was originally used in large stationary and marine engines. But it is now obsolete. In this method, the air is first compressed to very high pressure. A blast of this air is then injected carrying the fuel along with it into the cylinder. The rate of fuel injection is controlled by varying the pressure of the air. The high pressure air requires multistage compressor so as to keep the air bottles charged. The fuel ignites by the high temperature of the air caused by the high compression. The compressor consumes about 10% of the power developed by the engine, decreasing the net output of the engine. This method of fuel inject is expensive and complicated.



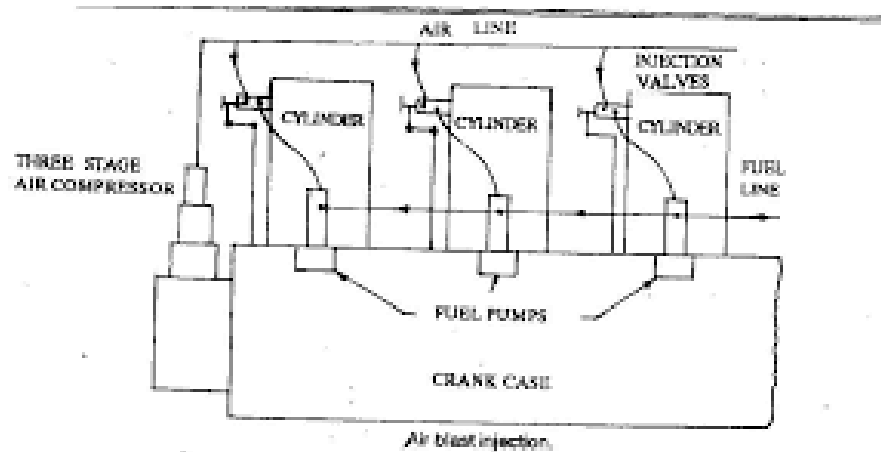

***Airless or Solid injection.*** In this method, the fuel under high pressure is directly injected into the combustion chamber. It burns due to the heat of compression of the air. This method requires a fuel pump to deliver the fuel at thight pressure. This method is used for all types of small and big diesel engines. It fan be divided into two systems.

**(a) Individual pump system.** In this system each cylinder has its own individual high pressure pump and a metering unit.

*Individual pump and nozzle system*

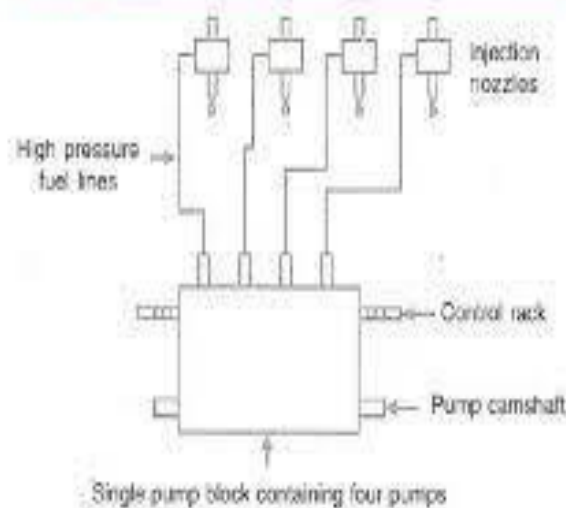

Fig. 8.1: Individual pump system

(b) **Common rail system.** In this system, the fuel is pumped by a multi cylinder pump into a common rail, the pressure in this rail is controlled by valve. A metered quantity of fuel is supplied to each cylinder from the common rail.

Fig.

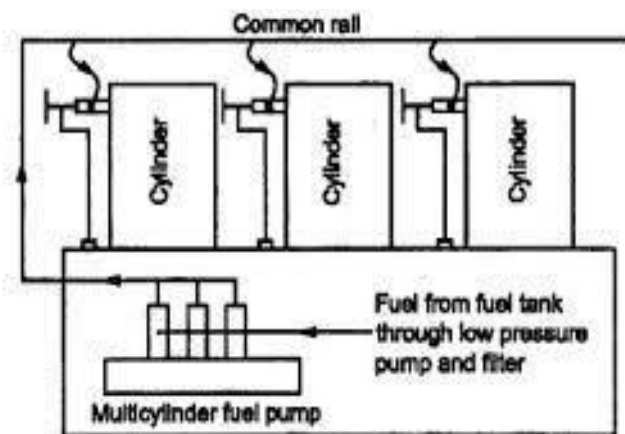

Figure 2.30 Common rail direct injection system

The airless injection in comparison to air blast injection, is simple in construction, light in weight and cheap. The fuel is atomized properly. It is quite suitable for engine of higher output, but it requires higher accuracy in manufacturing the pump barrel and fuel injection plunger.

### **Fuel filter for diesel Engine.**

Dirt carried in the fuel is recognized as a prime source of trouble and inefficiency in diesel engine operation, as it is the cause of wear in the fuel injection pump and nozzles. The fuel injection pump is a sturdy, well designed piece of equipment that will give double free service for many thousand of hours running provided the fuel is clean, but if dirt, and especially fine dust, is allowed to pass into the system in the fuel, then wear follows, and with it irregular running and loss of power: maintenance costs will become heavy and engines will need frequent attention. Where sedimentation in fuel. Under working

conditions, however, it is absolutely essential that the fuel be properly filtered before entering the injection pump.

Fig.

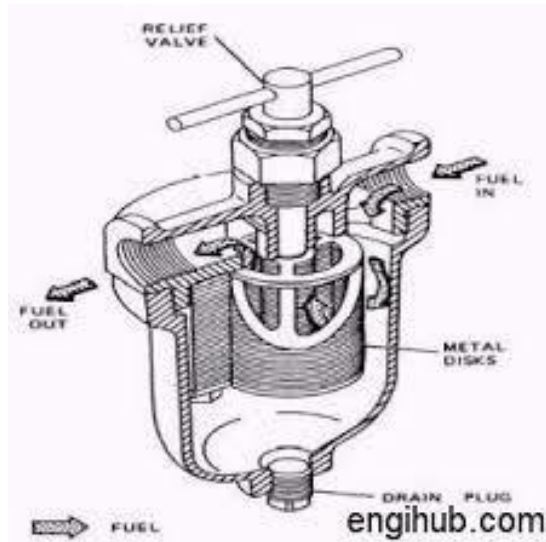

Prior to putting into operation or after cleaning and changing of the filter element the filter must be filled with fuel oil through the filter plug orifice on the filter cover. After filling, the filler plug should be replaced immediately and the filter air vented. Filter, cannot be over emphasized, as many complaints of fuel pump element wear can be traced to lack of care in the servicing of filters when choking takes place, this is usually found to be due to a waxy sludge which is deposited from the fuel. If filters are found to choke in an unreasonably short time this will probably point to an unsatisfactory fuel supply or storage tank installation, and should be taken to find out how, and at what point an undue amount of impurities can enter the system.

Paper elements are not intended to be cleaned and must be discarded when choked. The cost of replacement elements has been kept down to the lowest possible figure compatible with meticulous care in manufacture and compares more than favourably with other less efficient filtering elements. The number of filters used for any engine installation will obviously depend upon the capacity of the

particular engine and the conditions of operation. In all cases, the main object is to provide the highest possible degree of filtration consistent with long filter element life.

### Fuel Injector

The purpose of the fuel injector is to inject a small volume of fuel in a fine spray and to assist in bringing each droplet into contact with sufficient oxygen to give quick and complete combustion.

Fig.

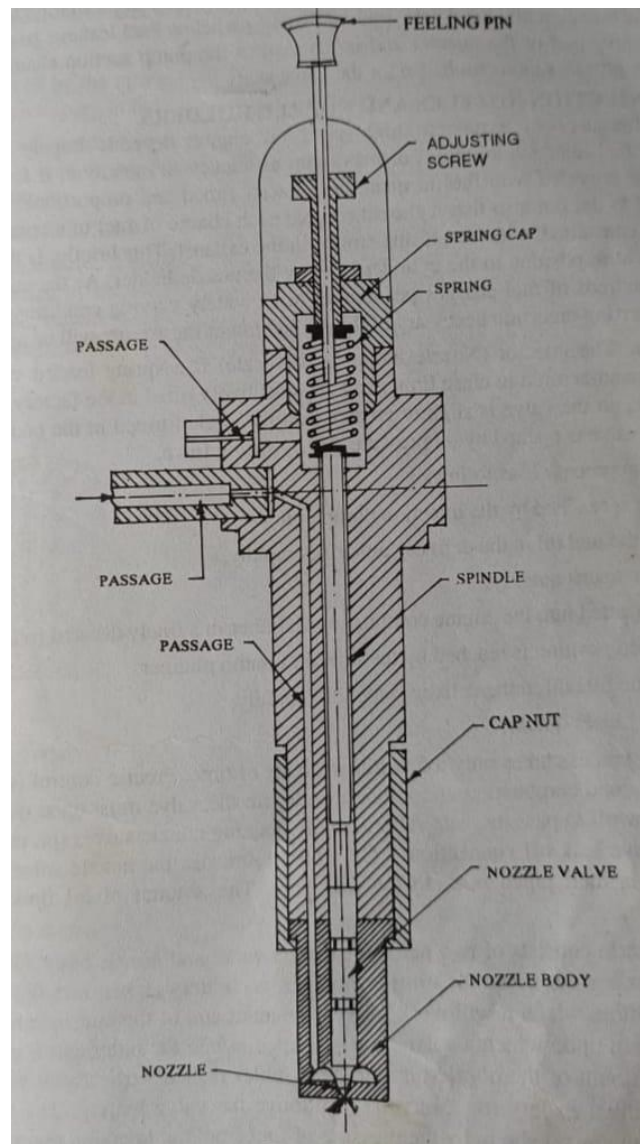

Shows C.A.V. fuel injector. It consists of a needle valve which is pressed on its seating in the nozzle by a plunger or spindle. A compression

spring controls the pressure upon the plunger by which the needle valve opens. A nozzle is attached to the body of the injector by a cap nut. The fuel enters the nozzle through drillings in the injector body. The fuel may pass from a gallery down the sides of the lower parts of the needle valve, or it may enter an annular groove in the nozzle and then pass through drillings to a point just above the nozzle seat. The body or a nozzle holder provides access for the fuel and an outlet for the fuel that leaks into the area occupied by the spring.

When the needle valve is raised from its seat by the pressure of the fuel acting on the conical or stepped face of the valve, the injection of the fuel takes place. When the injection pressure falls each injection and consequently breaks the fuel into small particles. Fuel leakage past the needle valve stem enters the upper part of the injector and is returned to the pump suction chamber or to the fuel tank. Fuel leakage provides lubrication also for the valve stem.

### **Fuel Feed Pumps.**

The fuel feed pump used for the diesel engine is similar to that of a fuel lift pump for the petrol engine. It delivers the fuel from the tank to the injection pump continuously and at a reasonable pressure. It is necessary because there is possibility of formation of vapor bubbles and subsequently cavitation in the pump due to suction of the rapidly moving plungers of the injection pump. This would lead to uncontrolled variations in the rate of delivery of fuel to the cylinders, causing rough running and possibly even cavitation could cause mechanical damage in the injection pump. Generally delivery pressures of between about 29 and 98kpa adequate for preventing vapour formation on the suction side of in line type injection pumps. This pressure also ensures adequate supply of fuel for filling the plunger elements at high speeds in a rotary distribution pump

## SHORT QUESTIONS.

1. What is carburetion ?
2. What is fuel injection ?
3. What is mpfi ?

## LONG QUESTIONS

1. Describe working of fuel injector ?
2. Describe mpfi system?
3. Describe about air fuel ratio?

# THE END

